



Chipsmall Limited consists of a professional team with an average of over 10 year of expertise in the distribution of electronic components. Based in Hongkong, we have already established firm and mutual-benefit business relationships with customers from,Europe,America and south Asia,supplying obsolete and hard-to-find components to meet their specific needs.

With the principle of “Quality Parts,Customers Priority,Honest Operation,and Considerate Service”,our business mainly focus on the distribution of electronic components. Line cards we deal with include Microchip,ALPS,ROHM,Xilinx,Pulse,ON,Everlight and Freescale. Main products comprise IC,Modules,Potentiometer,IC Socket,Relay,Connector.Our parts cover such applications as commercial,industrial, and automotives areas.

We are looking forward to setting up business relationship with you and hope to provide you with the best service and solution. Let us make a better world for our industry!



Contact us

Tel: +86-755-8981 8866 Fax: +86-755-8427 6832

Email & Skype: info@chipsmall.com Web: www.chipsmall.com

Address: A1208, Overseas Decoration Building, #122 Zhenhua RD., Futian, Shenzhen, China



THIS DRAWING IS UNPUBLISHED. RELEASED FOR PUBLICATION
 BY AMP INCORPORATED, ALL RIGHTS RESERVED.

LOC		DIST		REVISIONS			
P	LTR	DESCRIPTION		DATE	DWN	APVD	
AF	50	C		REV PER 063A-0294-02	19JUN02	JR	KAR

- 1 CONTINUOUS STRIP ON REELS WITH TERMINALS LOCATED ON 13.97±0.08 [.550±.003] CENTERS.
- 2 SLOT TERMINATES A SINGLE 0.8-0.9mm² [#18] AWG TIN PLATED SOLID, FUSED STRANDED OR STRANDED (7, 16, OR 19 STRANDS) WIRE WITH PET INSULATION, 2.03[.080] MAX DIA.
- 3 SLOT ACCEPTS 0.45-0.64mm [#25-#22] AWG COPPER MAGNET WIRE. SINGLE OR DOUBLE WIRE OF THE SAME SIZE AND TYPE. EXCEPT 0.64mm [#22] AWG WHICH IS FOR ONE WIRE ONLY.
- 4 SLOT ACCEPTS 0.54-0.81mm [#23.5-#20] AWG COPPER MAGNET WIRE. 2 WIRES OF THE SAME SIZE AND TYPE PER SLOT. EXCEPT 0.64-0.81 [#22-#20] AWG WHICH IS ONE WIRE ONLY.
- 5 MTA PRODUCT SPEC IS 108-1051
MAG-MATE PRODUCT SPEC IS 108-2012
- 6 MAG-MATE APPLICATION SPEC IS 114-2046
MTA APPLICATION SPEC IS 114-1020
- 7 TERMINALS ARE STRESS RELIEVED

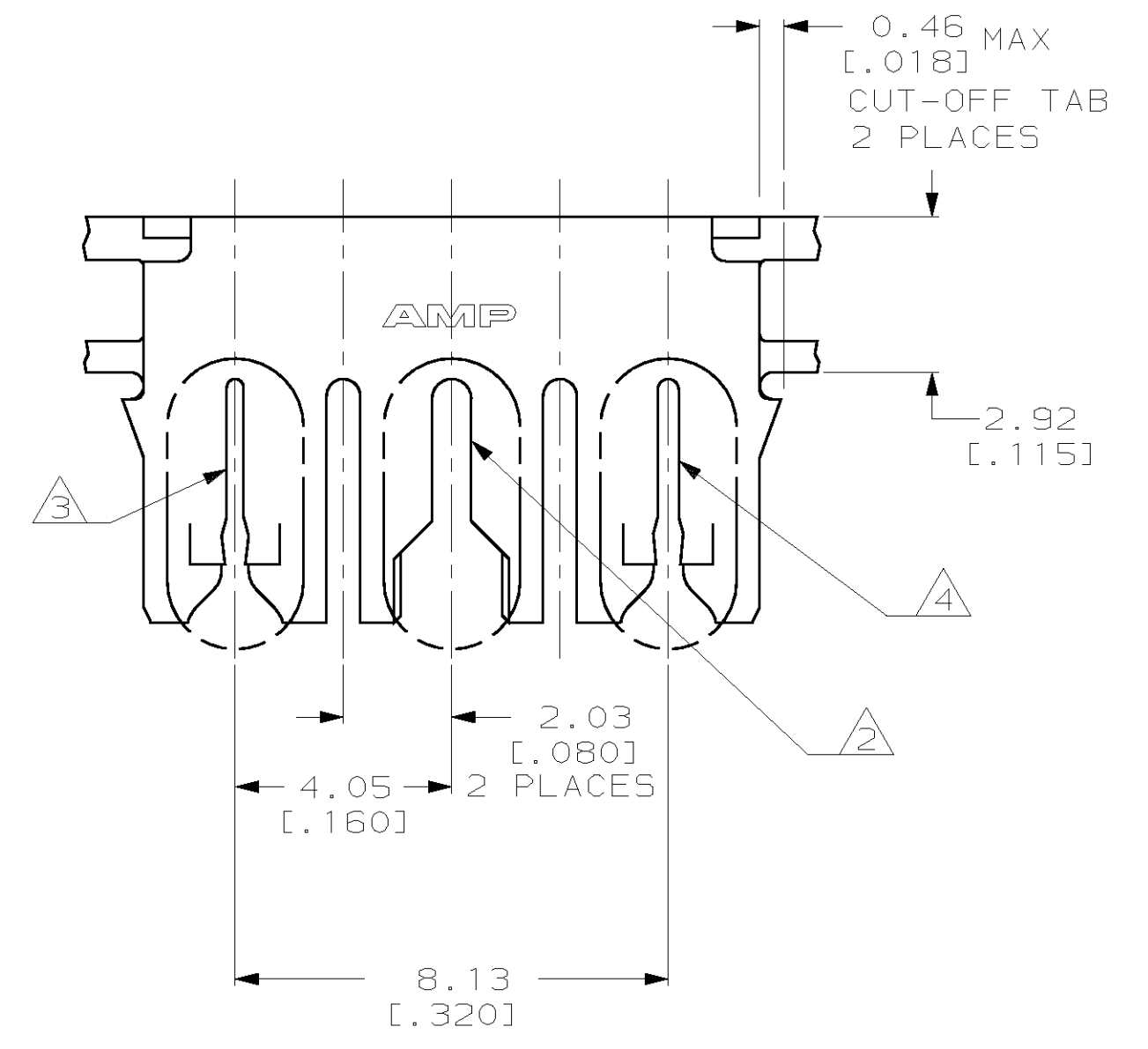
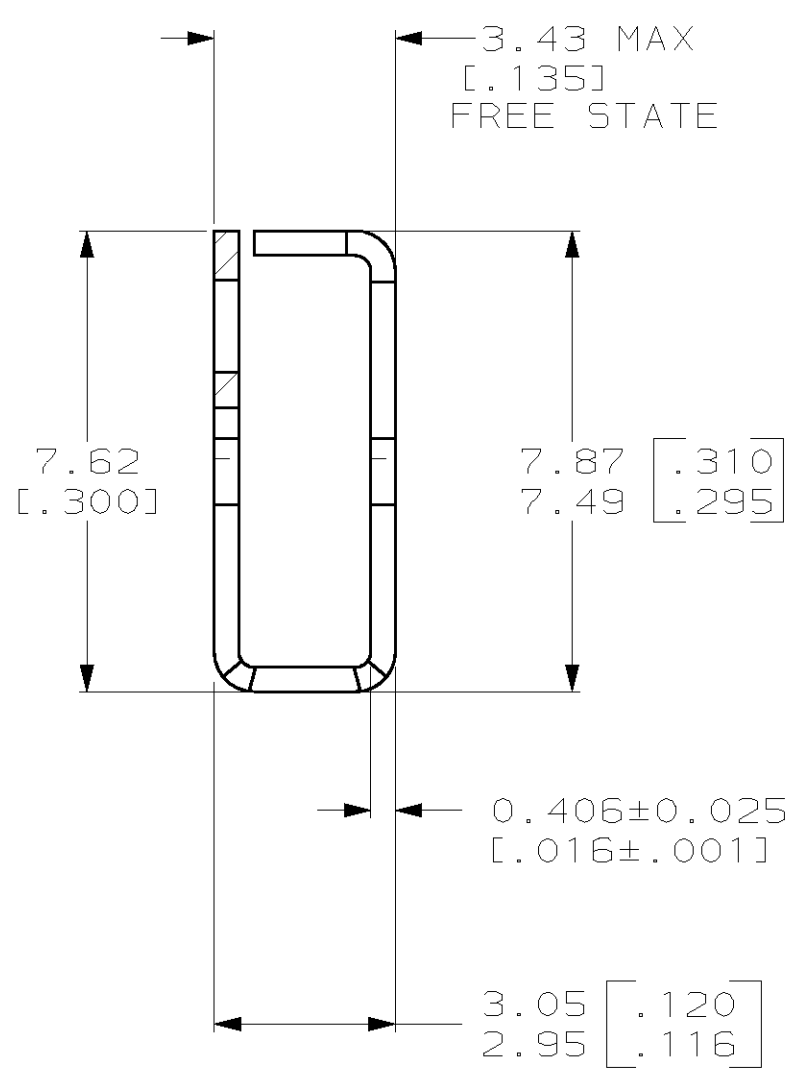
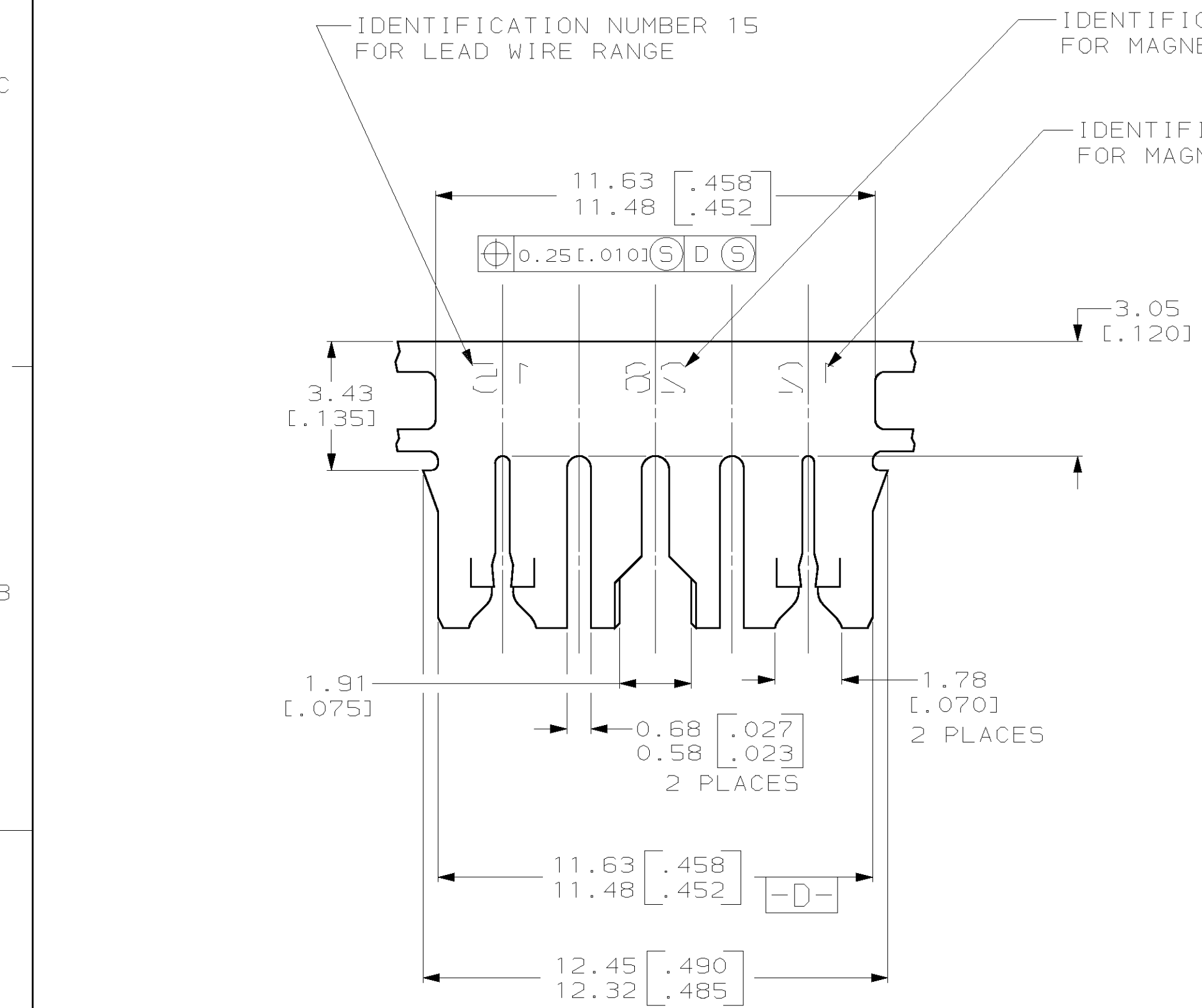
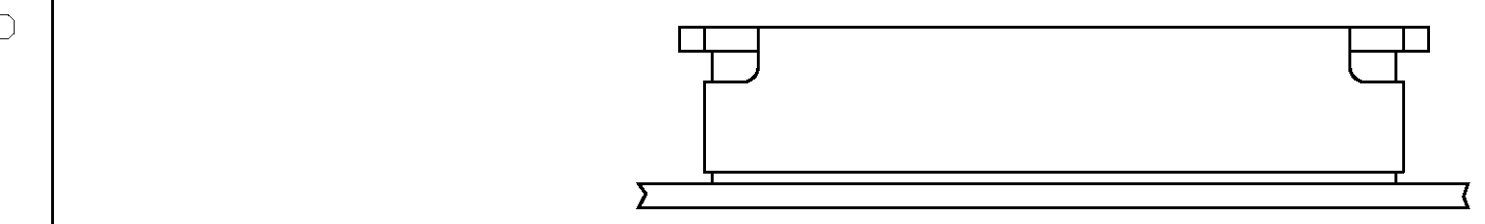

1217209-1
PART NUMBER

THIS DRAWING IS A CONTROLLED DOCUMENT.		DWN	13SEP1999	AMP Incorporated Harrisburg, PA 17105-3608
		CHK	22SEP1999	
		APVD	22SEP1999	
		NAME	KURT A. RANDOLPH	
DIMENSIONS: mm [INCHES]		TOLERANCES UNLESS OTHERWISE SPECIFIED:		PRODUCT SPEC
		0 PLC ±-		APPLICATION SPEC
		1 PLC ±-		96-1039-143
		2 PLC ±0.25[.010]		SIZE
		3 PLC ±-		CAGE CODE
		4 PLC ±-		DRAWING NO
		ANGLES ±-		RESTRICTED TO
MATERIAL 4M BRASS		FINISH 0.002032[.000080]		SCALE
		MIN TIN PLATE		8:1
		CUSTOMER DRAWING		SHEET
				1 OF
				REV
				C