



Chipsmall Limited consists of a professional team with an average of over 10 year of expertise in the distribution of electronic components. Based in Hongkong, we have already established firm and mutual-benefit business relationships with customers from,Europe,America and south Asia,supplying obsolete and hard-to-find components to meet their specific needs.

With the principle of “Quality Parts,Customers Priority,Honest Operation,and Considerate Service”,our business mainly focus on the distribution of electronic components. Line cards we deal with include Microchip,ALPS,ROHM,Xilinx,Pulse,ON,Everlight and Freescale. Main products comprise IC,Modules,Potentiometer,IC Socket,Relay,Connector.Our parts cover such applications as commercial,industrial, and automotives areas.

We are looking forward to setting up business relationship with you and hope to provide you with the best service and solution. Let us make a better world for our industry!



Contact us

Tel: +86-755-8981 8866 Fax: +86-755-8427 6832

Email & Skype: info@chipsmall.com Web: www.chipsmall.com

Address: A1208, Overseas Decoration Building, #122 Zhenhua RD., Futian, Shenzhen, China



THIS DRAWING IS UNPUBLISHED. RELEASED FOR PUBLICATION
 © COPYRIGHT BY TYCO ELECTRONICS CORPORATION. ALL RIGHTS RESERVED.

LOC		DIST		REVISIONS			
P	LTR	DESCRIPTION		DATE	DWN	APVD	
AF	50	C2	REVISED PER ECR-07-030461	27DEC07	HMR	KR	

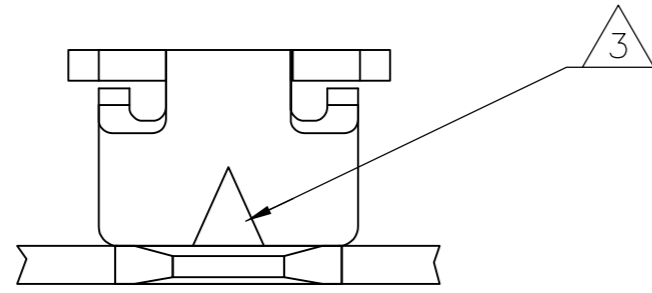

- 1 CONTINUOUS STRIP ON REELS WITH TERMINALS LOCATED ON 5.59±0.08 [.220±.003] CENTERS.
- 2 SLOT ACCEPTS 0.45-0.64mm [#25-#22] AWG COPPER MAGNET WIRE. 2 WIRES OF THE SAME SIZE PER SLOT EXCEPT 0.64mm [#22] AWG WHICH IS ONE WIRE ONLY.
- 3 POKE-IN ACCEPTS A 0.5-0.8mm² [#20-#18] AWG SOLID OR FUSED STRANDED LEAD WIRE.

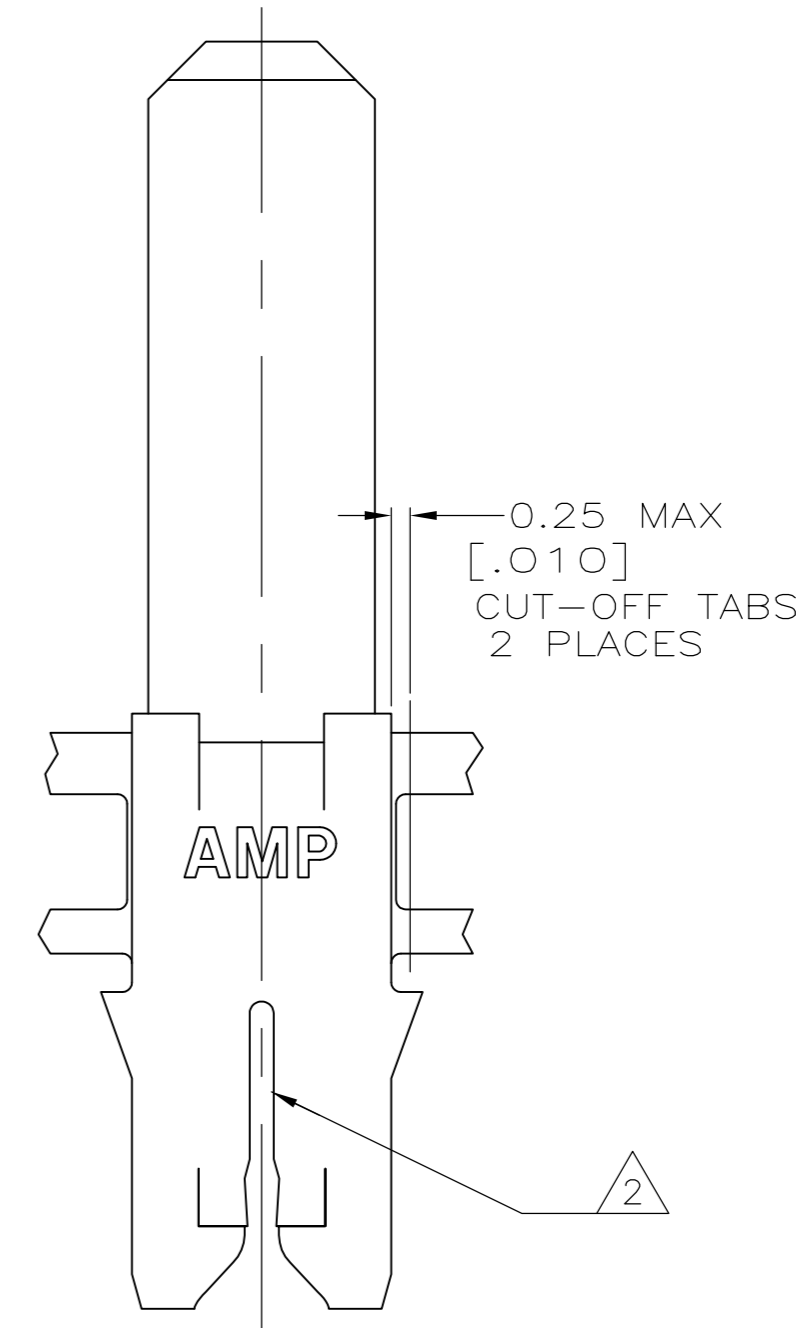
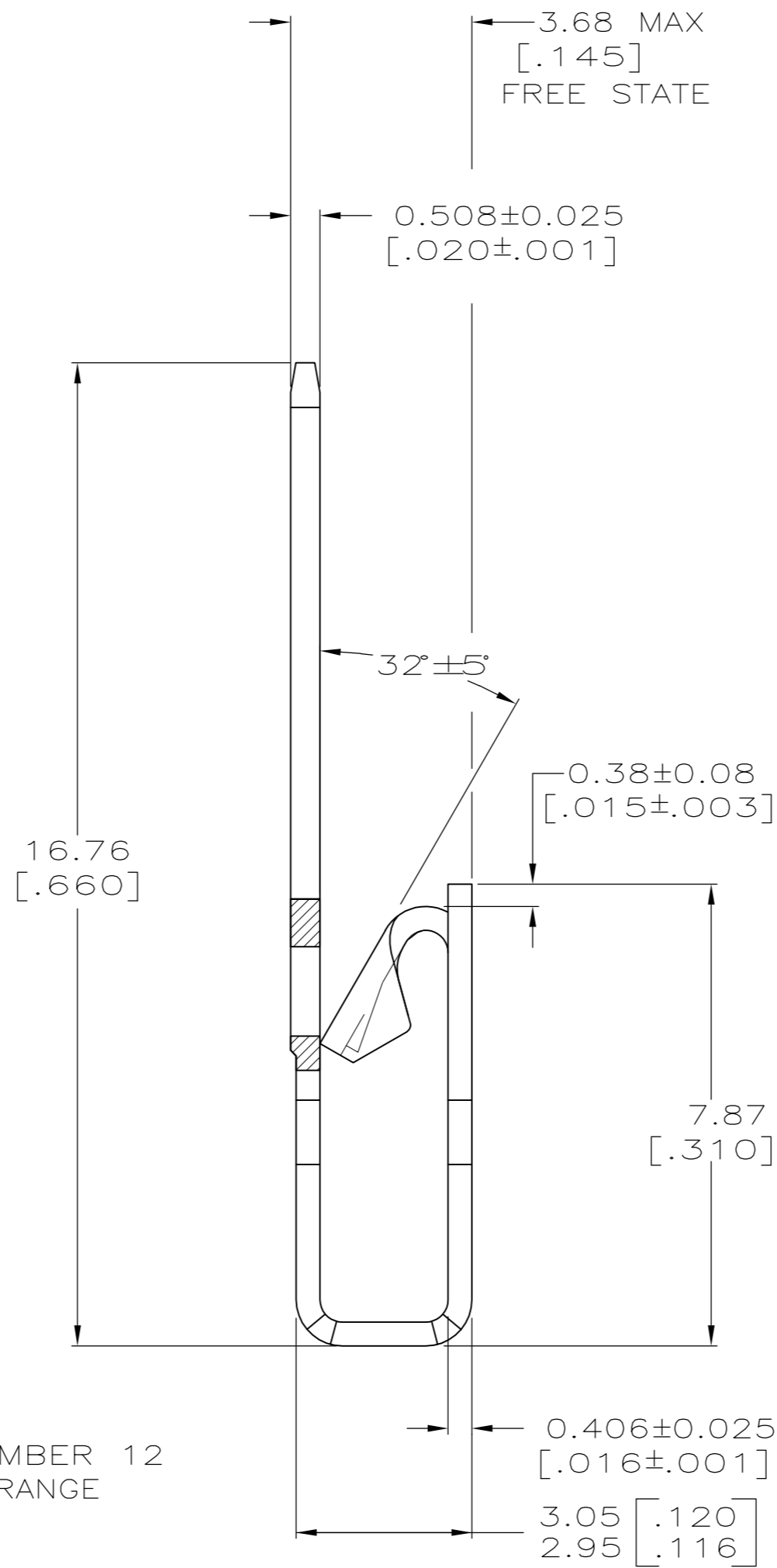
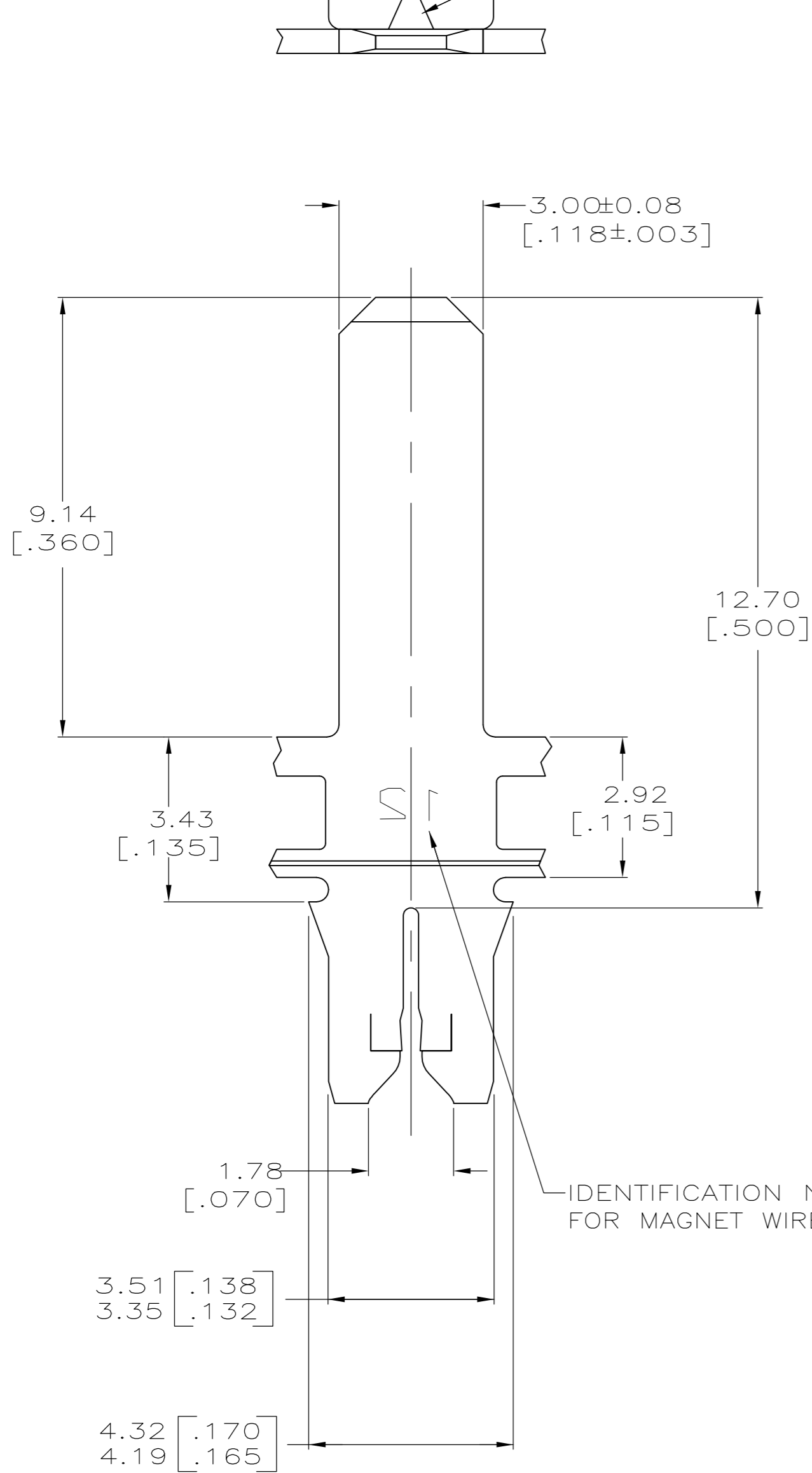

REVERSE	1217210-2
STANDARD	1217210-1
REELING	PART NUMBER

THIS DRAWING IS A CONTROLLED DOCUMENT.		DWN 14SEP1999 MICHAEL S. FEHER	Tyco Electronics Corporation Harrisburg, PA 17105-3608	
DIMENSIONS: mm		CHK 22SEP1999 KURT A. RANDOLPH	NAME	
TOLERANCES UNLESS OTHERWISE SPECIFIED:		APVD 22SEP1999 KURT A. RANDOLPH	TAB, POKE-IN/3.00[.118] SERIES, COMBINATION, 300 SERIES MAG-MATE	
0 PLC ± -	1 PLC ± -	PRODUCT SPEC	SIZE	CAGE CODE
2 PLC ± 0.25[.010]	3 PLC ± -	108-2012	A2	00779
4 PLC ± -	ANGLES ± -	APPLICATION SPEC	DRAWING NO	RESTRICTED TO
MATERIAL 4M PRE-MILLED	FINISH 0.002032[.000080]	114-2046	C=1217210	-
CUSTOMER DRAWING		WEIGHT -	SCALE 10:1	SHEET 1 of 1
		REV C2		