



Chipsmall Limited consists of a professional team with an average of over 10 year of expertise in the distribution of electronic components. Based in Hongkong, we have already established firm and mutual-benefit business relationships with customers from,Europe,America and south Asia,supplying obsolete and hard-to-find components to meet their specific needs.

With the principle of “Quality Parts,Customers Priority,Honest Operation,and Considerate Service”,our business mainly focus on the distribution of electronic components. Line cards we deal with include Microchip,ALPS,ROHM,Xilinx,Pulse,ON,Everlight and Freescale. Main products comprise IC,Modules,Potentiometer,IC Socket,Relay,Connector.Our parts cover such applications as commercial,industrial, and automotives areas.

We are looking forward to setting up business relationship with you and hope to provide you with the best service and solution. Let us make a better world for our industry!



## Contact us

Tel: +86-755-8981 8866 Fax: +86-755-8427 6832

Email & Skype: info@chipsmall.com Web: www.chipsmall.com

Address: A1208, Overseas Decoration Building, #122 Zhenhua RD., Futian, Shenzhen, China



THIS DRAWING IS UNPUBLISHED. RELEASED FOR PUBLICATION  
 © COPYRIGHT BY TYCO ELECTRONICS CORPORATION. ALL RIGHTS RESERVED.

LOC		DIST		REVISIONS			
P	LTR	DESCRIPTION		DATE	DWN	APVD	
	E2	REVISED PER ECR-07-030483		21DEC07	HMR	KR	

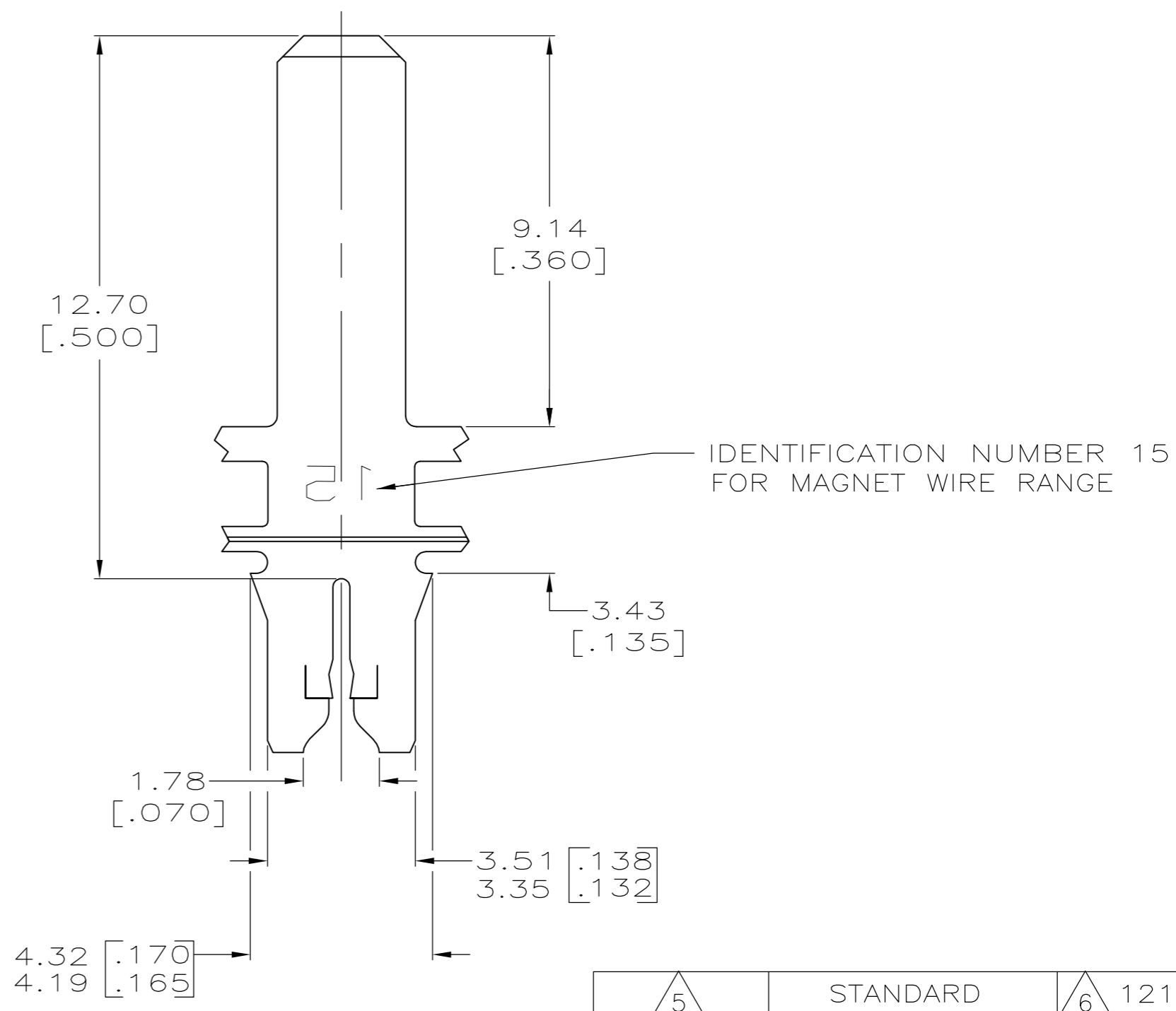
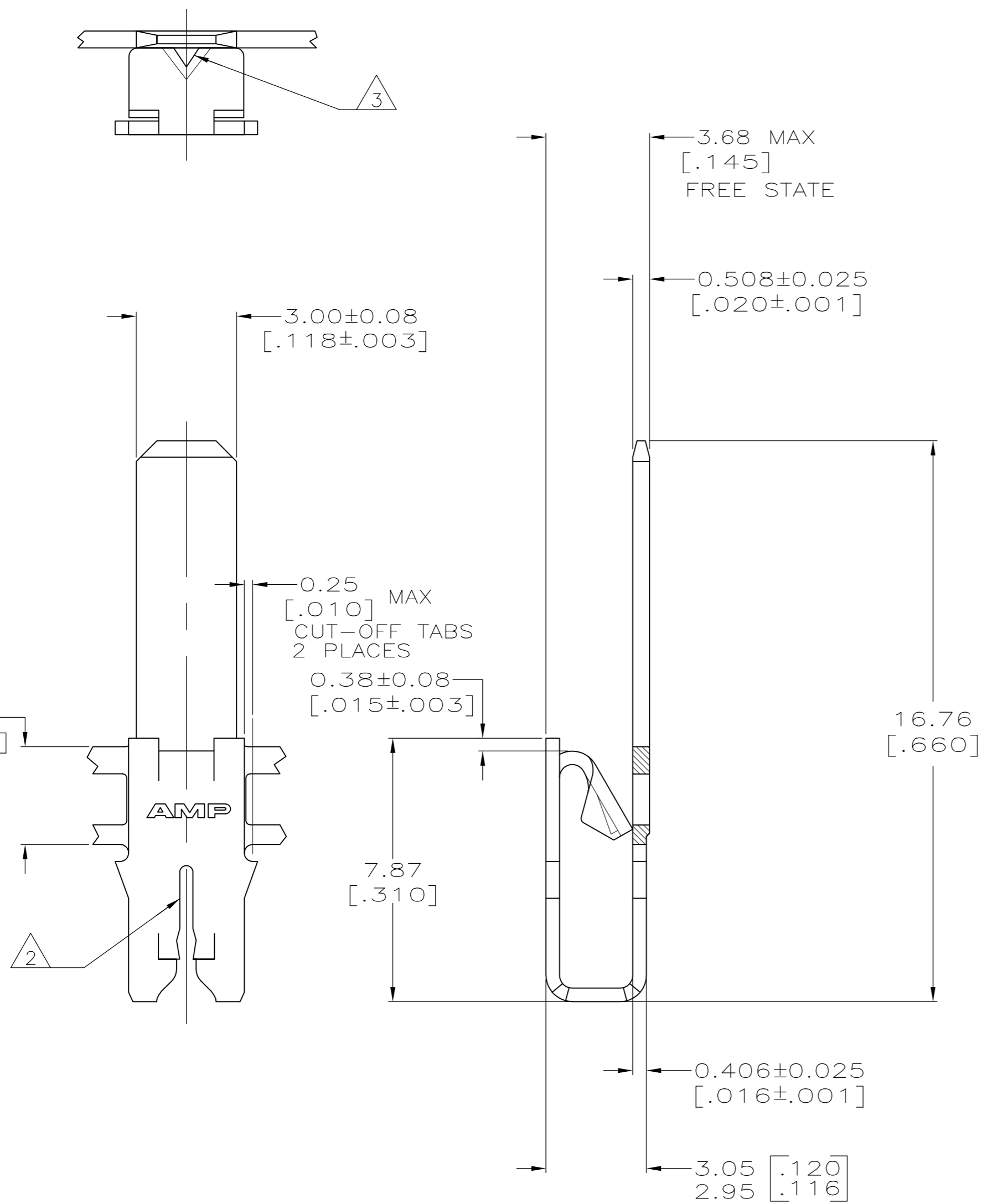

- 1 CONTINUOUS STRIP ON REELS WITH TERMINALS LOCATED ON 5.59±0.08[.220±.003] CENTERS.
- 2 SLOT ACCEPTS 0.54-0.81mm [#23.5-#20] AWG COPPER MAGNET WIRE. 2 WIRES OF THE SAME AND TYPE PER SLOT. EXCEPT 0.64-0.81mm [#22-#20] AWG WHICH IS ONE WIRE ONLY.
- 3 POKE-IN ACCEPTS A 0.5-0.8mm<sup>2</sup> [#20-#18] AWG SOLID OR FUSED STRANDED LEAD WIRE.
- 4 0.002032 [.000080] MIN TIN PLATE
- 5 0.001270 [.000050] MIN NICKEL PLATE.
- 6 PRELIMINARY - NOT FOR PRODUCTION.

5	STANDARD	6	1217211-3
4	STANDARD		1217211-2
4	REVERSE		1217211-1
FINISH		REELING	
		PART NUMBER	

THIS DRAWING IS A CONTROLLED DOCUMENT.		DWN 14SEP1999 MICHAEL S. FEHER	Tyco Electronics Corporation Harrisburg, PA 17105-3608	
DIMENSIONS: mm [INCHES]		CHK 22SEP1999 KURT A. RANDOLPH	NAME TAB, POKE-IN/3.00[.118] SERIES, COMBINATION, 300 SERIES MAG-MATE	
TOLERANCES UNLESS OTHERWISE SPECIFIED: 0 PLC ± - 1 PLC ± - 2 PLC ± 0.25[.010] 3 PLC ± - 4 PLC ± - ANGLES ± -		APVD 22SEP1999 KURT A. RANDOLPH	PRODUCT SPEC 108-2012	
MATERIAL 4M PRE-MILLED BRASS		FINISH SEE TABLE	APPLICATION SPEC 114-2046	RESTRICTED TO -
		WEIGHT -	SIZE A2	CAGE CODE 00779
		CUSTOMER DRAWING	DRAWING NO C=1217211	SCALE 8:1
			SHEET 1 of 1	REV E2

1217211