



Chipsmall Limited consists of a professional team with an average of over 10 year of expertise in the distribution of electronic components. Based in Hongkong, we have already established firm and mutual-benefit business relationships with customers from,Europe,America and south Asia,supplying obsolete and hard-to-find components to meet their specific needs.

With the principle of “Quality Parts,Customers Priority,Honest Operation,and Considerate Service”,our business mainly focus on the distribution of electronic components. Line cards we deal with include Microchip,ALPS,ROHM,Xilinx,Pulse,ON,Everlight and Freescale. Main products comprise IC,Modules,Potentiometer,IC Socket,Relay,Connector.Our parts cover such applications as commercial,industrial, and automotives areas.

We are looking forward to setting up business relationship with you and hope to provide you with the best service and solution. Let us make a better world for our industry!



Contact us

Tel: +86-755-8981 8866 Fax: +86-755-8427 6832

Email & Skype: info@chipsmall.com Web: www.chipsmall.com

Address: A1208, Overseas Decoration Building, #122 Zhenhua RD., Futian, Shenzhen, China



THIS DRAWING IS UNPUBLISHED. RELEASED FOR PUBLICATION
 © COPYRIGHT BY TYCO ELECTRONICS CORPORATION. ALL RIGHTS RESERVED.

LOC		DIST		REVISIONS			
P	LTR	DESCRIPTION		DATE	DWN	APVD	
AF	50	B		REVISED PER ECR-06-010412	02NOV06	HMR KR	



- 1 CONTINUOUS STRIP ON REELS WITH TERMINALS LOCATED ON 8.38±0.08 [.330±.003] CENTERS.
- 2 SLOT ACCEPTS A SINGLE COPPER MAGNET WIRE. WIRE RANGE: 0.57-0.81mm [#23-#20] AWG.

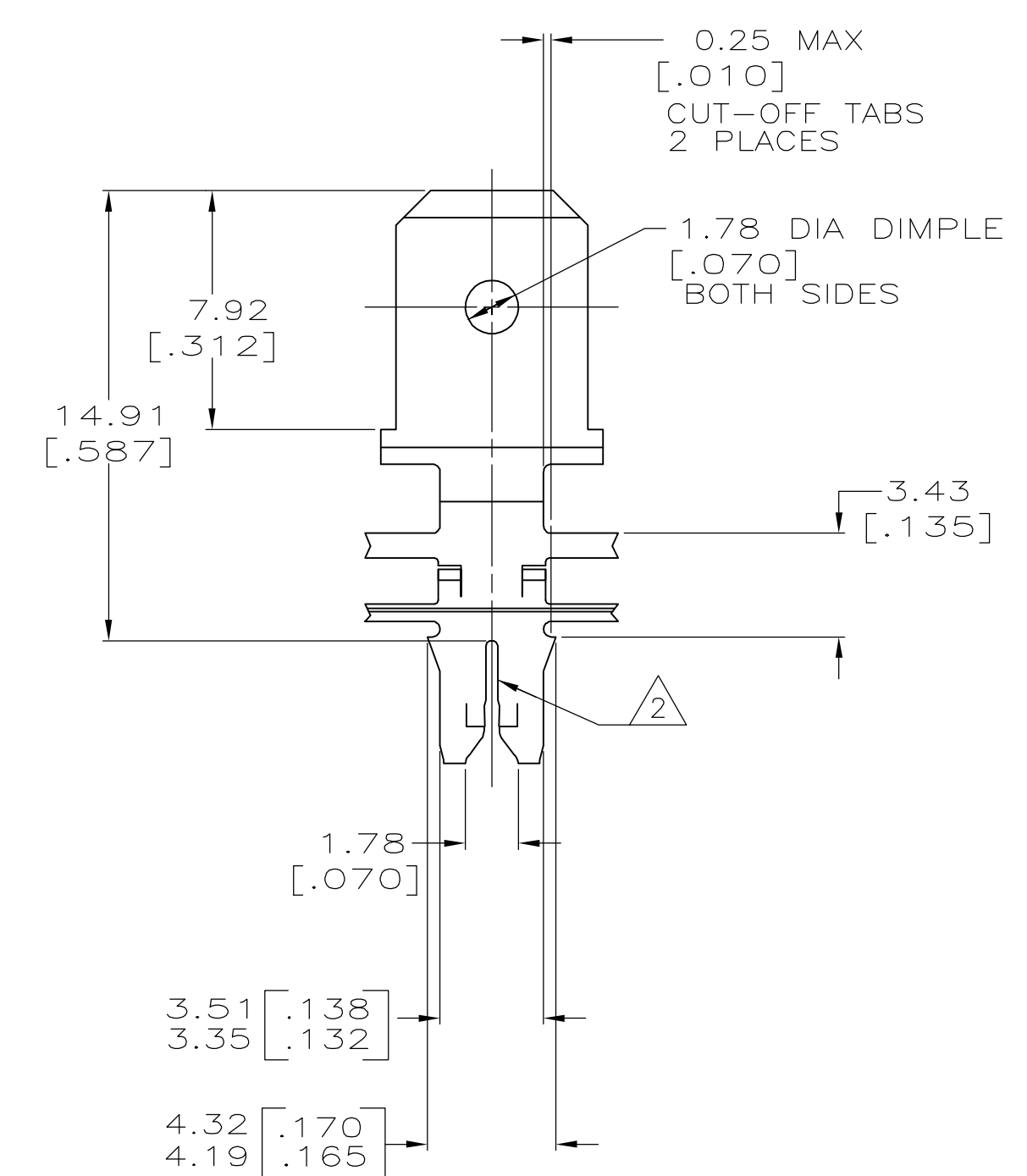
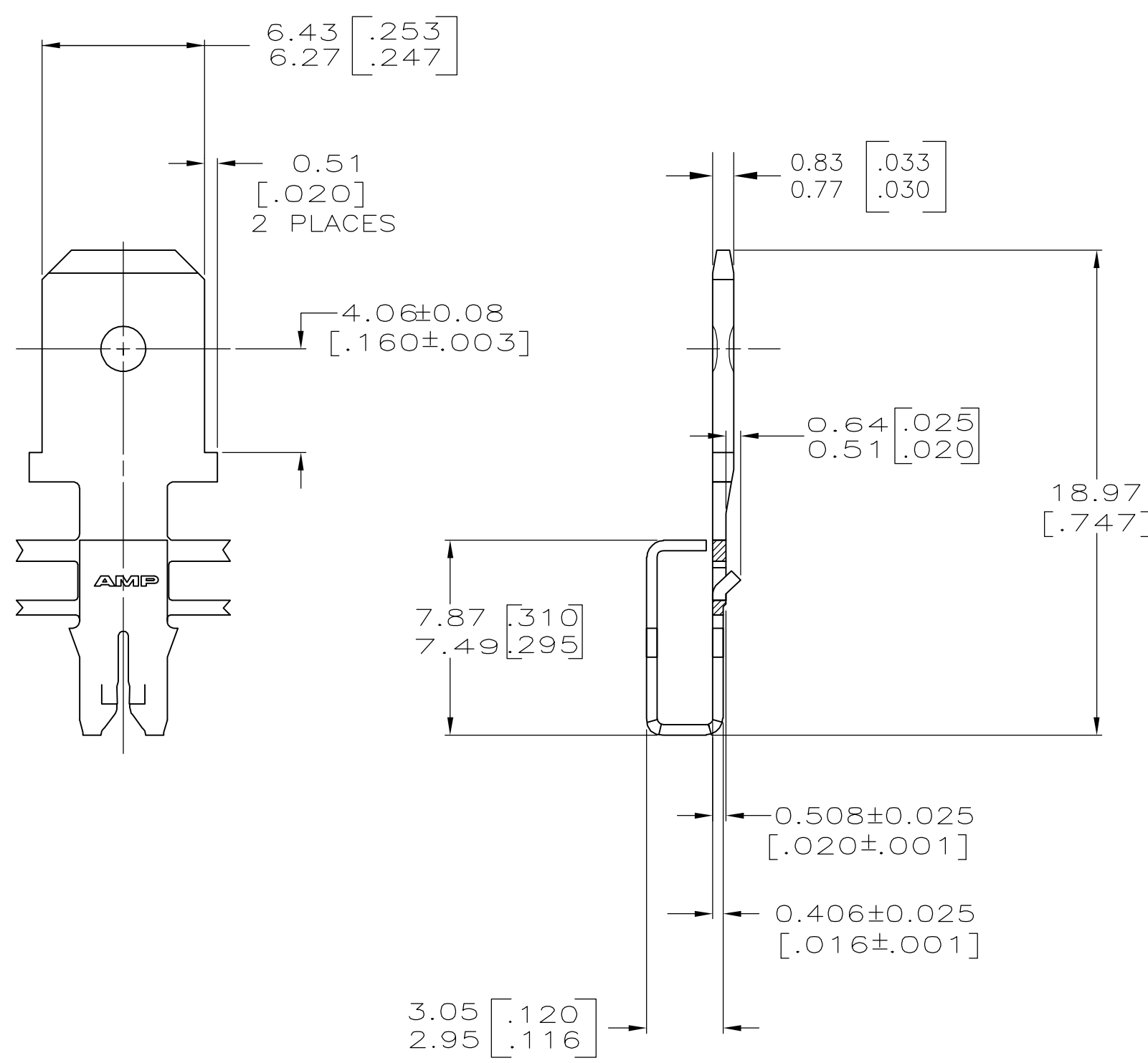

1217870-1
PART NUMBER

THIS DRAWING IS A CONTROLLED DOCUMENT.		DWN MICHAEL S. FEHER	30AUG2002	tyco Electronics	Tyco Electronics Corporation Harrisburg, PA 17105-3608	
DIMENSIONS: mm [INCHES]		CHK KURT A. RANDOLPH	30AUG2002		NAME KURT A. RANDOLPH	
TOLERANCES UNLESS OTHERWISE SPECIFIED:		APVD KURT A. RANDOLPH	30AUG2002	PRODUCT SPEC 108-2012		
0 PLC ± -		APPLICATION SPEC 114-2067		SIZE A2		CAGE CODE 00779
1 PLC ± -		MATERIAL 082 PRE-MILLED		DRAWING NO 1217870		RESTRICTED TO -
2 PLC ± 0.25[.010]		FINISH 0.002032[.000080]		WEIGHT -		SCALE 5:1
3 PLC ± -		CUSTOMER DRAWING		SHEET 1 of 1		REV B
4 PLC ± -						
ANGLES ± -						