



Chipsmall Limited consists of a professional team with an average of over 10 year of expertise in the distribution of electronic components. Based in Hongkong, we have already established firm and mutual-benefit business relationships with customers from,Europe,America and south Asia,supplying obsolete and hard-to-find components to meet their specific needs.

With the principle of "Quality Parts,Customers Priority,Honest Operation,and Considerate Service",our business mainly focus on the distribution of electronic components. Line cards we deal with include Microchip,ALPS,ROHM,Xilinx,Pulse,ON,Everlight and Freescale. Main products comprise IC,Modules,Potentiometer,IC Socket,Relay,Connector.Our parts cover such applications as commercial,industrial, and automotives areas.

We are looking forward to setting up business relationship with you and hope to provide you with the best service and solution. Let us make a better world for our industry!



Contact us

Tel: +86-755-8981 8866 Fax: +86-755-8427 6832

Email & Skype: info@chipsmall.com Web: www.chipsmall.com

Address: A1208, Overseas Decoration Building, #122 Zhenhua RD., Futian, Shenzhen, China



THIS DRAWING IS UNPUBLISHED. RELEASED FOR PUBLICATION
 © COPYRIGHT BY TYCO ELECTRONICS CORPORATION. ALL RIGHTS RESERVED.

LOC		DIST		REVISIONS			
P	LTR	DESCRIPTION		DATE	DWN	APVD	
	C	REV PER ECR 05-018400		05JAN06	JR	KR	

1 SUPPLIED IN LOOSE PIECE

- 2 SLOT ACCEPTS 0.64-0.81mm [#22-#20] AWG COPPER MAGNET WIRE. SINGLE OR DOUBLE WIRE OF THE SAME SIZE AND TYPE.
- 3 SPECIAL CAVITY ANVIL LOCATION REQUIRED 4.83±0.07 [.190±.003]. REF APPLICATION SPEC. 114-2046, SEC 3.21, NOTE 7, REVISION T OR LATER.
- 4 BLACK COLORING APPLIED TO THIS SURFACE DURING LOOSE PIECE OPERATION TO PROVIDE COLOR CODING OF MAGNET WIRE RANGE.

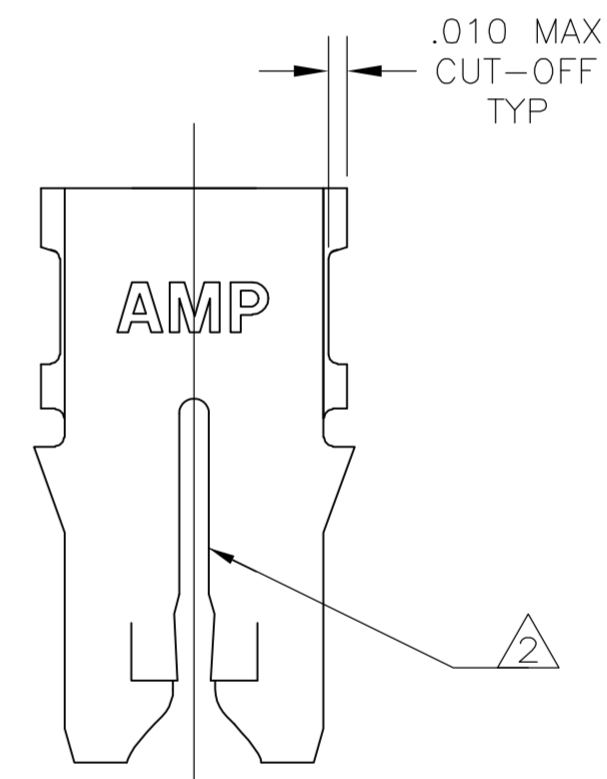
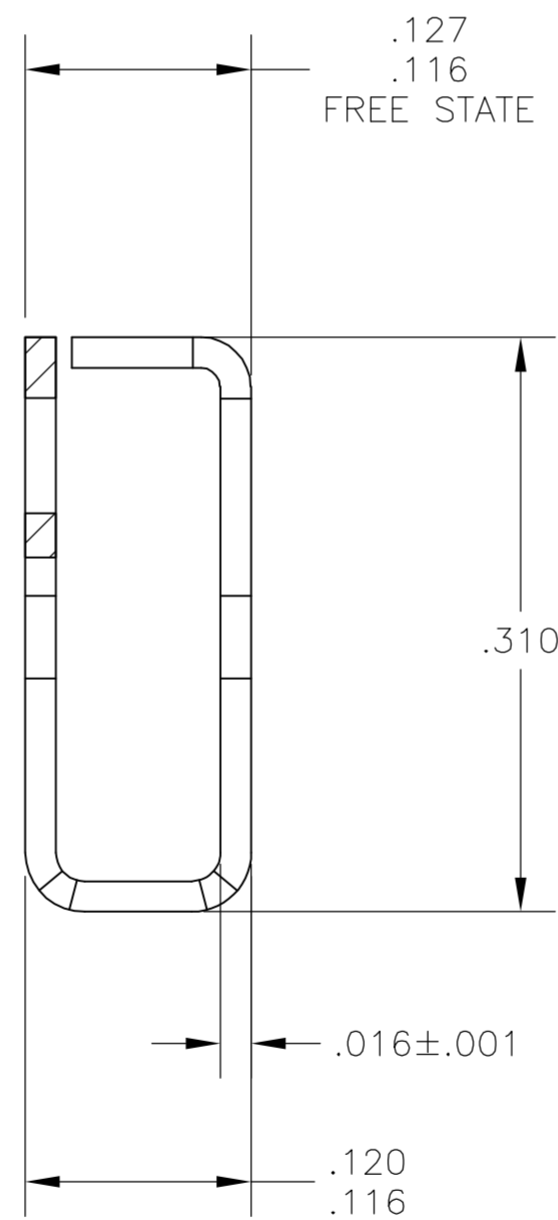
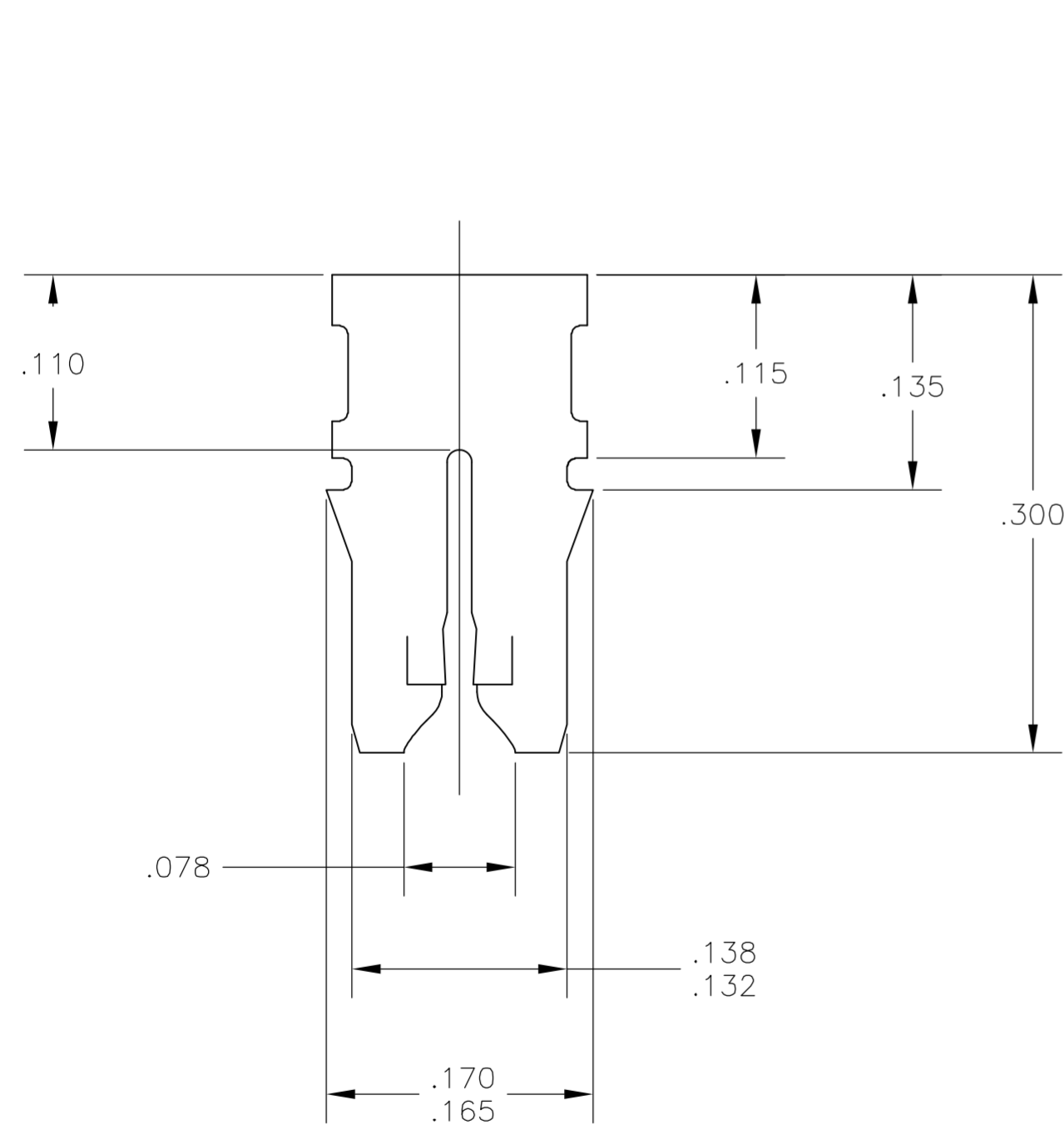
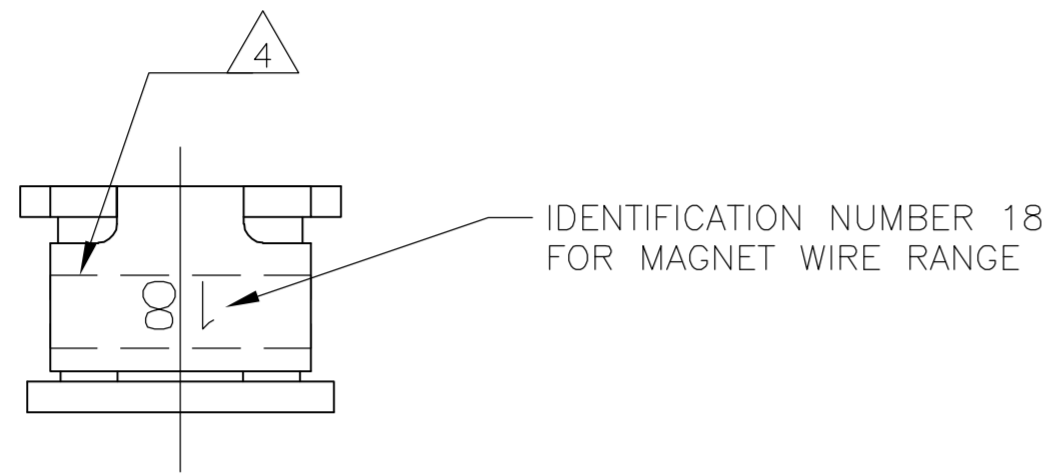

1217974-1
PART NUMBER

THIS DRAWING IS A CONTROLLED DOCUMENT.		DWN jr ruth 15JUL03	Tyco Electronics Corporation Harrisburg, PA 17105-3608	
DIMENSIONS: INCHES		CHK KURT A. RANDOLPH 15JUL03	NAME KURT A. RANDOLPH	
TOLERANCES UNLESS OTHERWISE SPECIFIED:		APVD KURT A. RANDOLPH 15JUL03	PRODUCT SPEC 108-2012	
0 PLC ± - 1 PLC ± - 2 PLC ± .010 3 PLC ± - 4 PLC ± - ANGLES ± -		APPLICATION SPEC 114-2046 3	SIZE A2	CAGE CODE 00779
MATERIAL H04 PHOS BRONZE	FINISH .000080 MIN TIN	WEIGHT -	DRAWING NO 1217974	RESTRICTED TO -
CUSTOMER DRAWING			SCALE 10:1	SHEET 1 of 1