



Chipsmall Limited consists of a professional team with an average of over 10 year of expertise in the distribution of electronic components. Based in Hongkong, we have already established firm and mutual-benefit business relationships with customers from,Europe,America and south Asia,supplying obsolete and hard-to-find components to meet their specific needs.

With the principle of “Quality Parts,Customers Priority,Honest Operation,and Considerate Service”,our business mainly focus on the distribution of electronic components. Line cards we deal with include Microchip,ALPS,ROHM,Xilinx,Pulse,ON,Everlight and Freescale. Main products comprise IC,Modules,Potentiometer,IC Socket,Relay,Connector.Our parts cover such applications as commercial,industrial, and automotives areas.

We are looking forward to setting up business relationship with you and hope to provide you with the best service and solution. Let us make a better world for our industry!



Contact us

Tel: +86-755-8981 8866 Fax: +86-755-8427 6832

Email & Skype: info@chipsmall.com Web: www.chipsmall.com

Address: A1208, Overseas Decoration Building, #122 Zhenhua RD., Futian, Shenzhen, China



THIS DRAWING IS UNPUBLISHED. RELEASED FOR PUBLICATION
 © COPYRIGHT BY TYCO ELECTRONICS CORPORATION. ALL RIGHTS RESERVED.

LOC	DIST	REVISIONS			
P	LTR	DESCRIPTION	DATE	DWN	APVD
AF	50	A	REL PER 0G3A-0745-03	24NOV03	JR KR

- 1 CONTINUOUS STRIP ON REELS ON .220±.003 CENTERS
- 2 SLOT TERMINATES EITHER A SINGLE OR DOUBLE MAGNET WIRE OF THE SAME SIZE AND TYPE. COPPER RANGE: #32-#29 AWG.
- 3 .000080 MIN TIN PLATE
- 4 POKE-IN ACCEPTS #20-#18 AWG SOLID OR FUSED STRANDED LEAD WIRE.

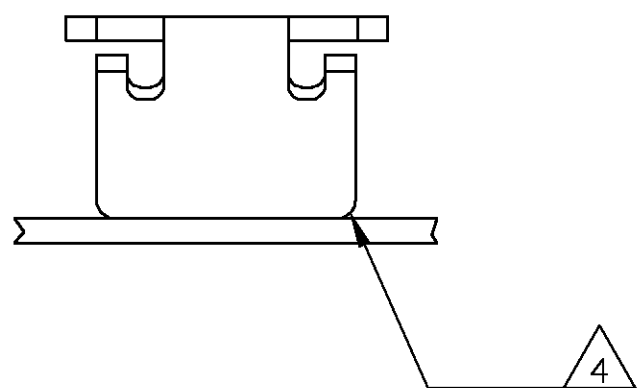

IDENTIFICATION NUMBER 5M FOR MAGNET WIRE RANGE

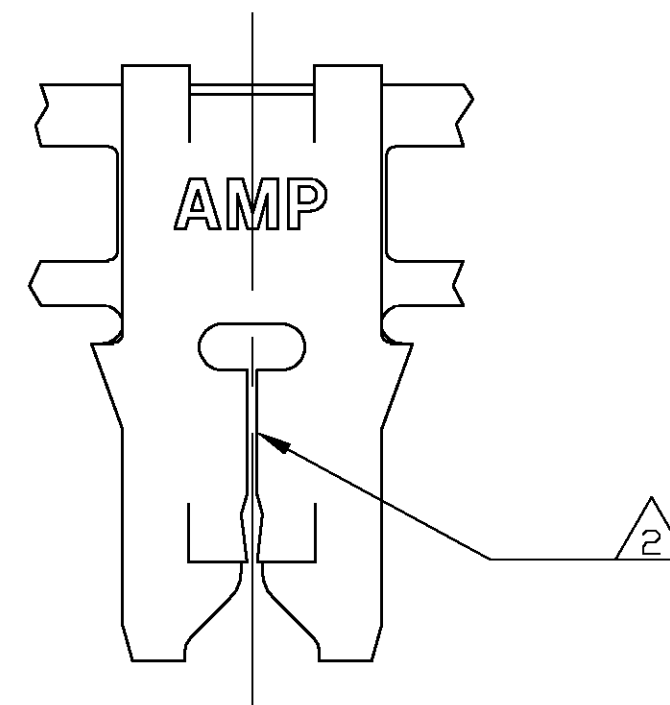
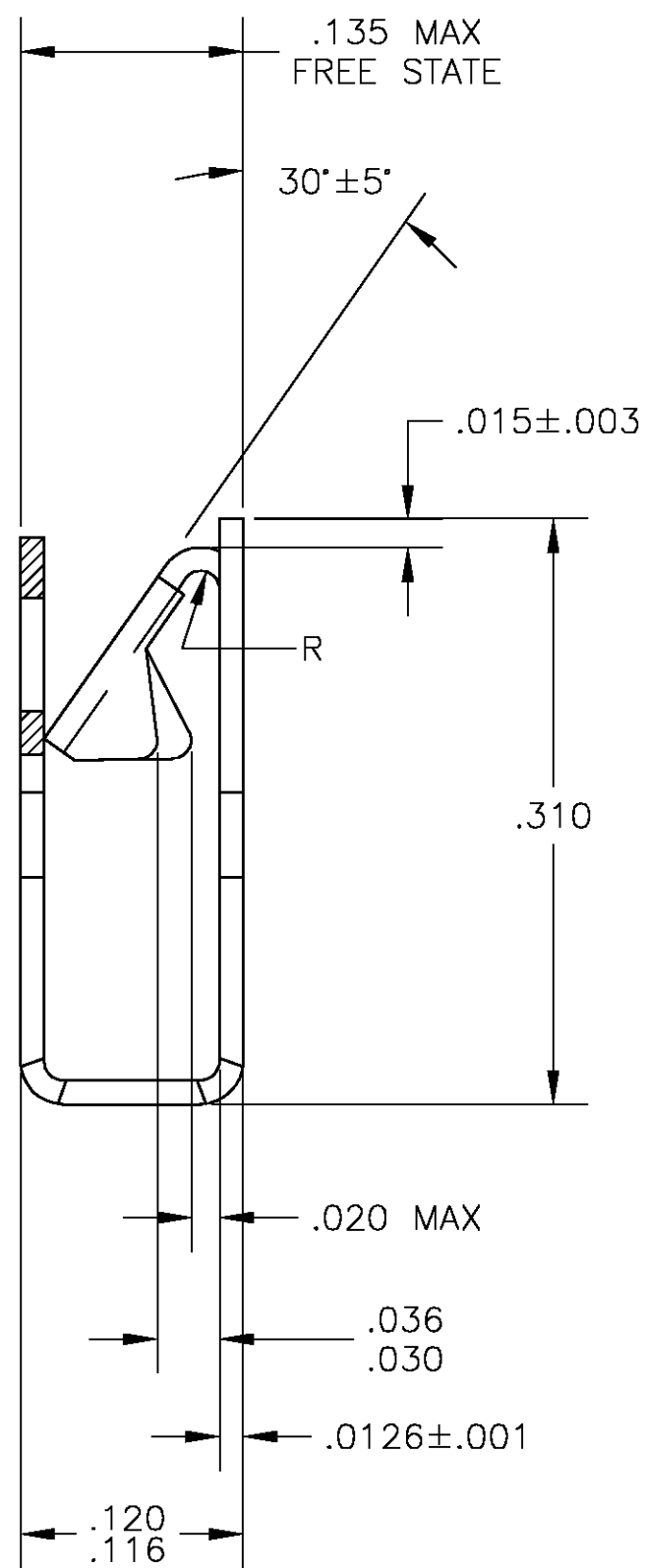
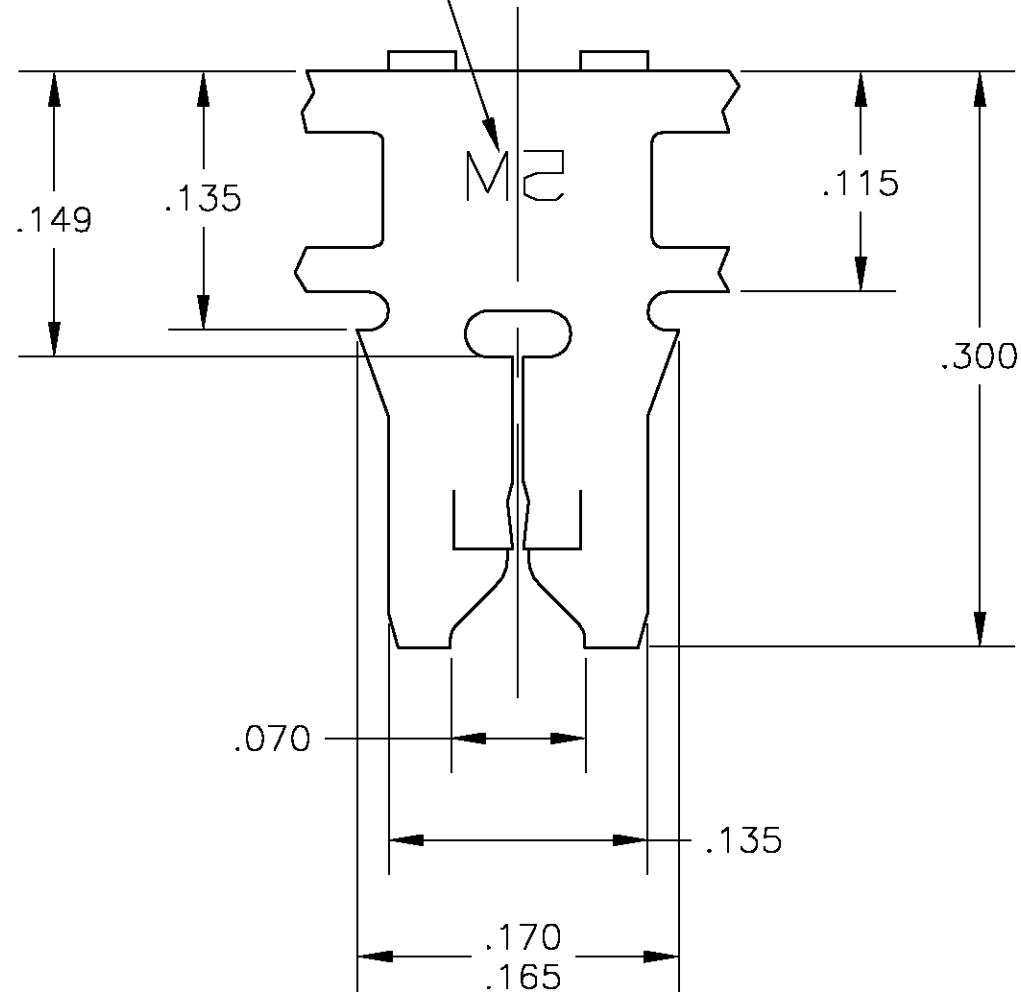

1217992-1
PART NO

THIS DRAWING IS A CONTROLLED DOCUMENT.		DWN MICHAEL S. FEHER 10SEP2003	Tyco Electronics Corporation Harrisburg, PA 17105	
DIMENSIONS: INCHES		CHK KURT A. RANDOLPH 10SEP2003	NAME KURT A. RANDOLPH	
TOLERANCES UNLESS OTHERWISE SPECIFIED:		APVD KURT A. RANDOLPH 10SEP2003	PRODUCT SPEC 108-2012	
0 PLC ± -		APPLICATION SPEC 114-2046	SIZE A2	CAGE CODE 00779
1 PLC ± -		WEIGHT -	DRAWING NO C=1217992	
2 PLC ± -		RESTRICTED TO -		
3 PLC ± .010		SCALE 10:1		
4 PLC ± -		SHEET 1 OF 1		
ANGLES ± 1°		REV A		
FINISH - 3		CUSTOMER DRAWING		