



Chipsmall Limited consists of a professional team with an average of over 10 year of expertise in the distribution of electronic components. Based in Hongkong, we have already established firm and mutual-benefit business relationships with customers from,Europe,America and south Asia,supplying obsolete and hard-to-find components to meet their specific needs.

With the principle of “Quality Parts,Customers Priority,Honest Operation,and Considerate Service”,our business mainly focus on the distribution of electronic components. Line cards we deal with include Microchip,ALPS,ROHM,Xilinx,Pulse,ON,Everlight and Freescale. Main products comprise IC,Modules,Potentiometer,IC Socket,Relay,Connector.Our parts cover such applications as commercial,industrial, and automotives areas.

We are looking forward to setting up business relationship with you and hope to provide you with the best service and solution. Let us make a better world for our industry!



Contact us

Tel: +86-755-8981 8866 Fax: +86-755-8427 6832

Email & Skype: info@chipsmall.com Web: www.chipsmall.com

Address: A1208, Overseas Decoration Building, #122 Zhenhua RD., Futian, Shenzhen, China



THIS DRAWING IS UNPUBLISHED. RELEASED FOR PUBLICATION
 © COPYRIGHT BY TYCO ELECTRONICS CORPORATION. ALL RIGHTS RESERVED.

LOC	DIST	REVISIONS			
P	LTR	DESCRIPTION	DATE	DWN	APVD
DF	A0				
A		REV PER ECO-06-007200	31MAR06	PY	KH

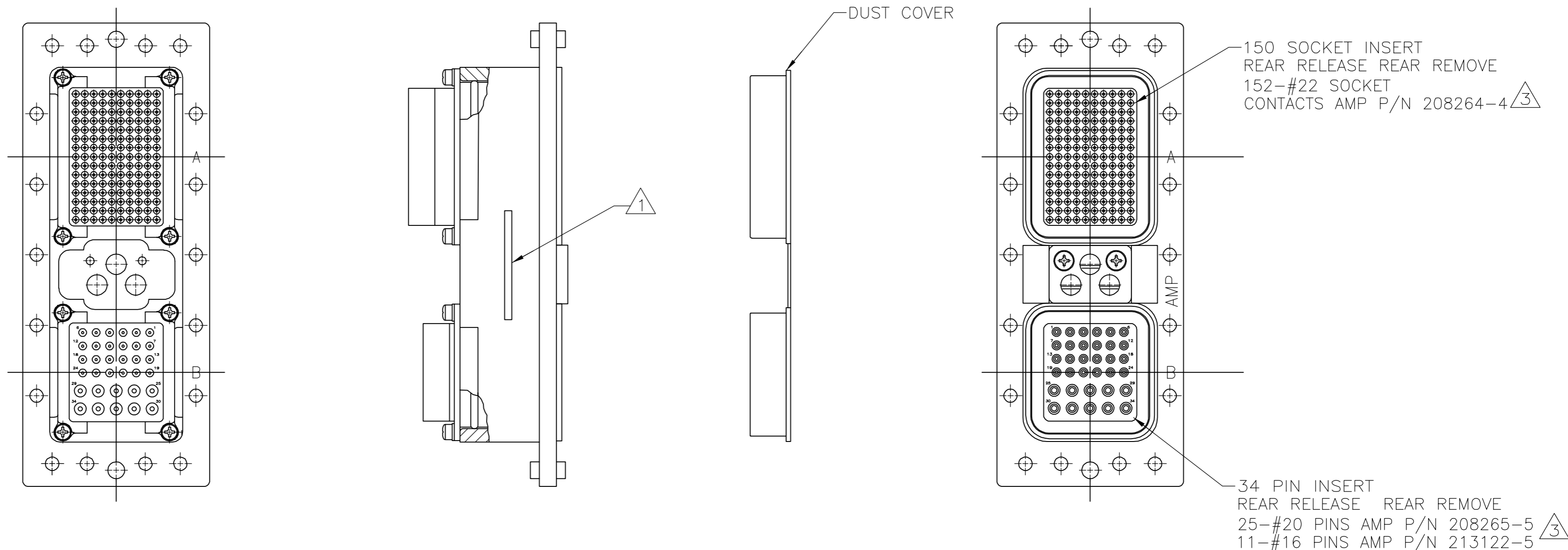

- 1. AMP, AMP PART NUMBER AND DATE CODE MARKED IN AREA SHOWN.
- 2. KEYED IN "01" POSITION.
- 3. PIN CONTACTS SIZES 16,20 & 22 ARE NOT LOADED IN CONNECTOR. THEY ARE PACKAGED IN SEPARATE CONTAINERS.

WARNING: THIS DOCUMENT CONTAINS TECHNICAL DATA WHOSE EXPORT IS RESTRICTED BY THE ARMS EXPORT CONTROL ACT (TITLE 22, U.S.C. SECTION 2751, ET SEQ.) OR THE EXPORT ADMINISTRATION ACT OF 1979, AS AMENDED (TITLE 50, U.S.C., APP. 2401 ET SEQ.) VIOLATIONS OF THESE EXPORT LAWS ARE SUBJECT TO SEVERE PENALTIES.

1218044-1
 PART NO.

THIS DRAWING IS A CONTROLLED DOCUMENT.		DWN	C.C.THOMAS	8-26-97	 Tyco Electronics Corporation Harrisburg, Pa 17105-3608
DIMENSIONS: INCHES		CHK	A.SHARPE	8-26-97	
TOLERANCES UNLESS OTHERWISE SPECIFIED:		APVD	A.SHARPE	8-26-97	
0 PLC ± - 1 PLC ± - 2 PLC ± - 3 PLC ± - 4 PLC ± - ANGLES ± - FINISH -		PRODUCT SPEC	NAME		
MATERIAL		APPLICATION SPEC	SIZE		RESTRICTED TO
		WEIGHT	CAGE CODE		
		CUSTOMER DRAWING	DRAWING NO		
		SCALE	SHEET		
		1:1	1 OF 1		
			REV		
			A		