



Chipsmall Limited consists of a professional team with an average of over 10 year of expertise in the distribution of electronic components. Based in Hongkong, we have already established firm and mutual-benefit business relationships with customers from,Europe,America and south Asia,supplying obsolete and hard-to-find components to meet their specific needs.

With the principle of “Quality Parts,Customers Priority,Honest Operation,and Considerate Service”,our business mainly focus on the distribution of electronic components. Line cards we deal with include Microchip,ALPS,ROHM,Xilinx,Pulse,ON,Everlight and Freescale. Main products comprise IC,Modules,Potentiometer,IC Socket,Relay,Connector.Our parts cover such applications as commercial,industrial, and automotives areas.

We are looking forward to setting up business relationship with you and hope to provide you with the best service and solution. Let us make a better world for our industry!



Contact us

Tel: +86-755-8981 8866 Fax: +86-755-8427 6832

Email & Skype: info@chipsmall.com Web: www.chipsmall.com

Address: A1208, Overseas Decoration Building, #122 Zhenhua RD., Futian, Shenzhen, China



LOC	DIST	REVISIONS			
P	LTR	DESCRIPTION	DATE	DNW	APVD
T		REV PER ECO-15-016611	23DEC15	KG	EO

- CONNECTOR DIMENSIONS ARE PER ARINC 600 SPECIFICATION.
 - CONNECTOR IS SUPPLIED WITH CONTACTS (PER TABLE) ASSEMBLED AS SHOWN.
 - KEYING SHOWN IN POSITION "01" FOR ILLUSTRATION ONLY. CONNECTORS SHIPPED WITH KEYING INSTALLED IN POSITION PER TABLE. FOR POSITION "00" KEYING HARDWARE SHIPPED UNASSEMBLED.
- △ WITH CONTACT FULLY SEATED TO REAR OF CAVITY.
- △ FOR 1218049-3 CUSTOMER P/N 2232591-4 REV D, AND DATE CODE MARKED ON CONNECTOR BODY.
- △ FOR 1218049-4 CUSTOMER CAGE CODE, CUSTOMER PART NO. AND CUSTOMER REV LEVEL AND TE CAGE CODE MARKED AS SHOWN BELOW:
 98571-2234352-1 REV (LETTER OR NUMBER)
 MFR 00779
- △ FOR 1218049-4 TE PART NO. AND DATE CODE MARKED IN THIS AREA.

REMARKS	DUST COVER INCLUDED	DIM A	CLINCH NUTS	KEYING POSITION	CONTACTS INCLUDED AND NOT INSTALLED	CONTACTS INCLUDED AND INSTALLED	PART NUMBER
	NO	.250 MIN	(6) #6-32 AS SHOWN SELF-LOCKING	09	---	MODULE A & B 150 POSN MONOBLOCKS QTY 2 MODULE C CAVITIES 1,2,3,4,5,6,7,8,9,10 & 11 1-448138-2 (#20 POSTED) 1-448139-4 (#16 POSTED) 448140-3 (#12 POSTED)	1218049-5
△△	YES	.250 MIN	(6) #6-32 AS SHOWN SELF-LOCKING	09	---	MODULE A & B 150 POSN MONOBLOCKS QTY 2 MODULE C CAVITIES 1,2,3,4,5,6,7,8,9,10 & 11 1-448138-2 (#20 POSTED) 1-448139-4 (#16 POSTED) 448140-3 (#12 POSTED)	1218049-4
△5	NO	.250 MIN	(6) #6-32 AS SHOWN SELF-LOCKING	09	---	MODULE A & B 211431-4 (SIZE 22) MODULE C CAVITIES 1,2,3,4,5,6,7,8,9,10 & 11 1-448138-2 (#20 POSTED) 1-448139-4 (#16 POSTED) 448140-3 (#12 POSTED)	1218049-3
	YES	△ .141-.181 [3.58-4.60]	(10) #4-40 FREE RUNNING	88	---	MODULE A & B 211431-2 (SIZE 22) (111) MODULE C 1-448140-2 (#12 POSTED) 2-448138-0 (#20 POSTED) SELECT LOAD PER DETAIL	1218049-2
	NO	.250 MIN	(6) #6-32 AS SHOWN SELF-LOCKING	09	1218241-2 (#12 SOLDER CUP) 1218240-2 (#20 SOLDER CUP)	MODULE A & B 211431-4 (SIZE 22) MODULE C CAVITIES 2,3,4,5,6,8,9,10 & 11 1-448138-2 (#20 POSTED) 1-448139-4 (#16 POSTED) 448140-3 (#12 POSTED)	1218049-1

THIS DRAWING IS A CONTROLLED DOCUMENT.		BIN J.A.Baker 09-24-97		 TE Connectivity	
DIMENSIONS: INCHES [mm]		TOLERANCES UNLESS OTHERWISE SPECIFIED:			
0 PLC ± - 1 PLC ± - 2 PLC ± - 3 PLC ± .010 [0.25] 4 PLC ± - ANGLES ± -		DIM J.A.Baker 10-20-97 CHK A.SHARPE APVD A.SHARPE 10-20-97 PRODUCT SPEC APPLICATION SPEC		NAME RCPT ASSY,SIZE 2,ARINC 600 SIZE CAGE CODE DRAWING NO RESTRICTED TO A1 00779 1218049	
MATERIAL SEE CALLOUTS		FINISH SEE CALLOUTS		WEIGHT -- CUSTOMER DRAWING SCALE 2:1 SHEET 1 OF 2 REV T	

LOC		DIST		REVISIONS			
P	LTR	DESCRIPTION	DATE	DNW	APVD		
-	-	SEE SHEET 1	-	-	-		

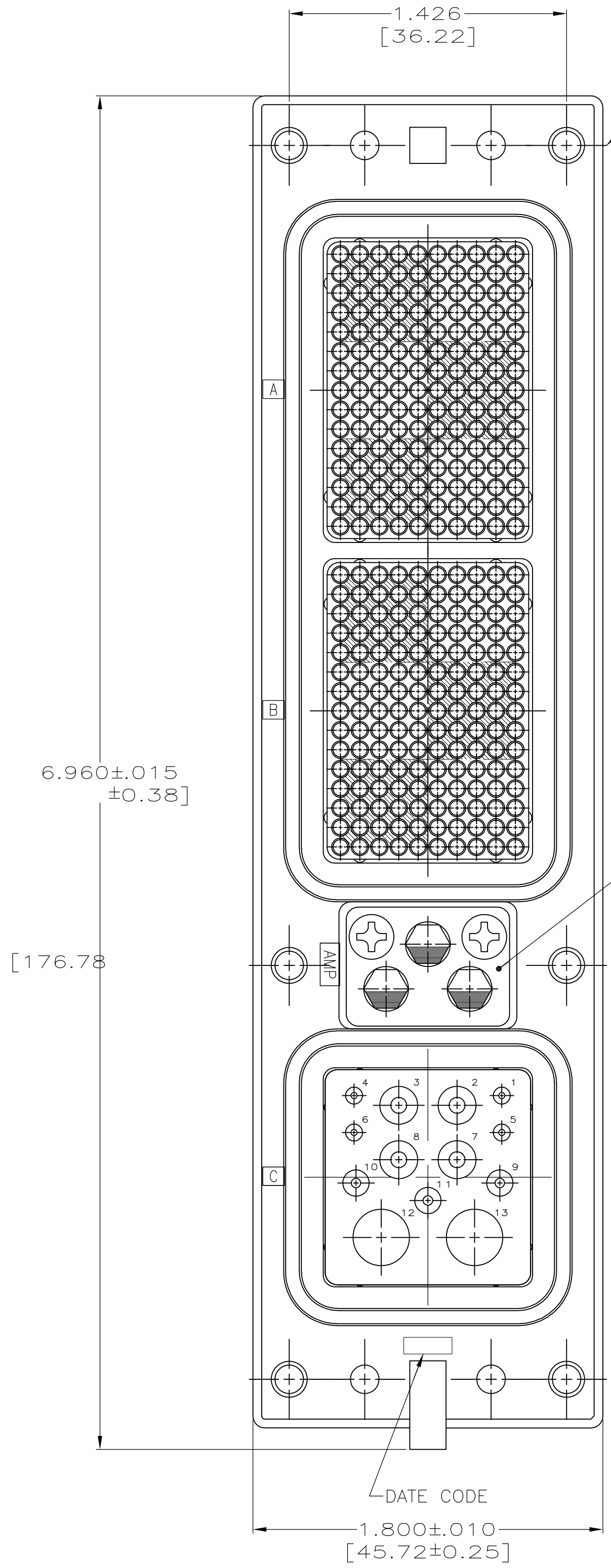

SHELL
MAT'L: ALUMINUM ALLOY
PER ASTM-B-85
FINISH: ENI PER
MIL-C-26074 CLASS 3
GRADE 8

PLATE & SCREWS

DUST COVER INSTALLED
MAT'L: CONDUCTIVE THEROPLASTIC
SEE TABLE

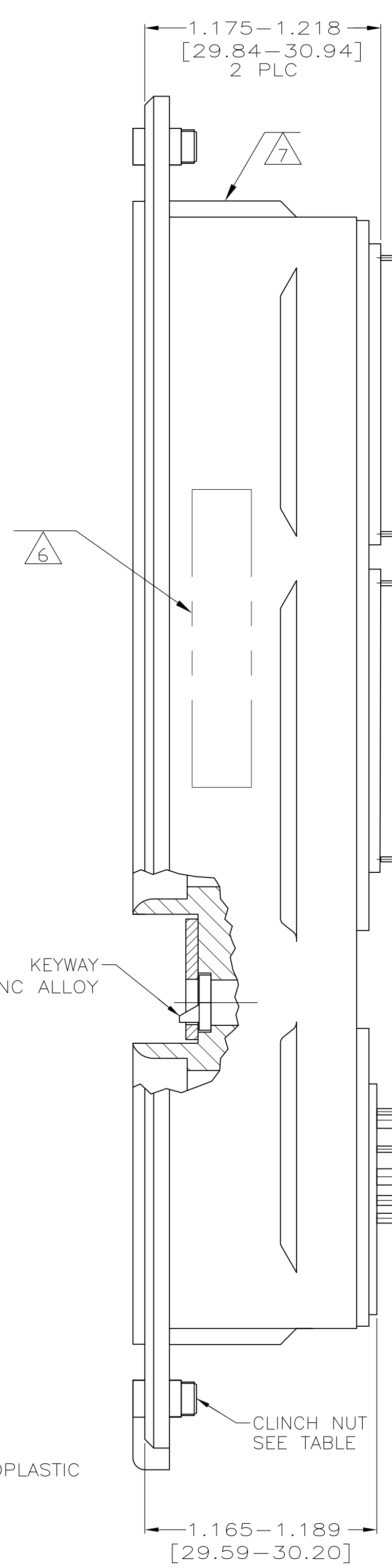

RETAINER
MAT'L: ALUMINUM ALLOY
FINISH: ENI

150 SOCKET INSERT ASSY
FRONT RELEASE-FRONT REMOVE
MAT'L: POLYPHENYLENE SULFIDE
PER MIL-M-24519
-4 & -5 ASSEMBLY MONOBLOCK
CONTACTS NOT REMOVABLE

#4-40 UNC SCREWS
FLAT HEAD, 10 PLACES

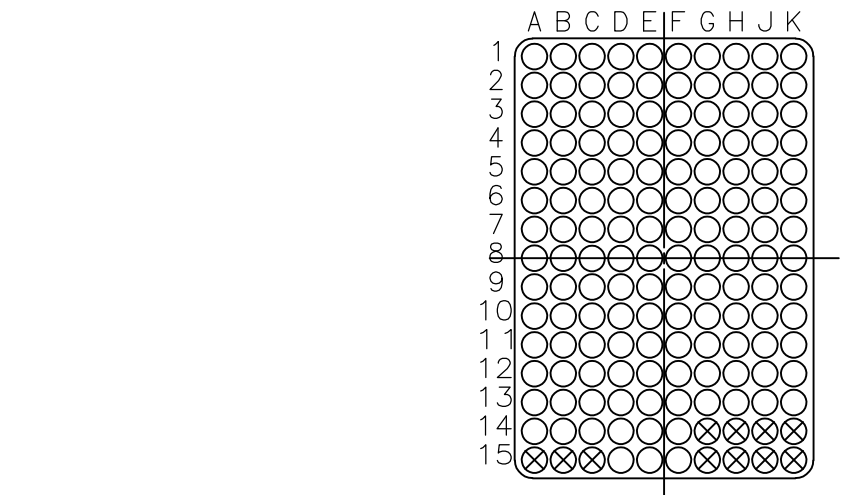
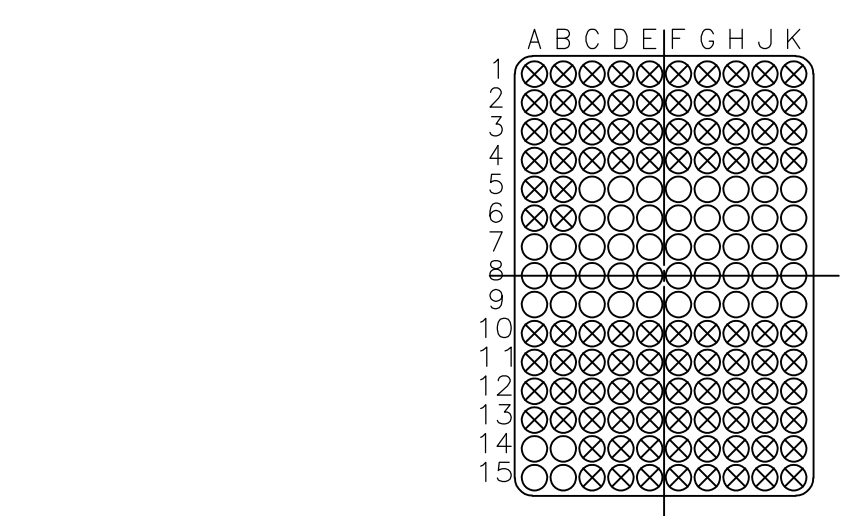
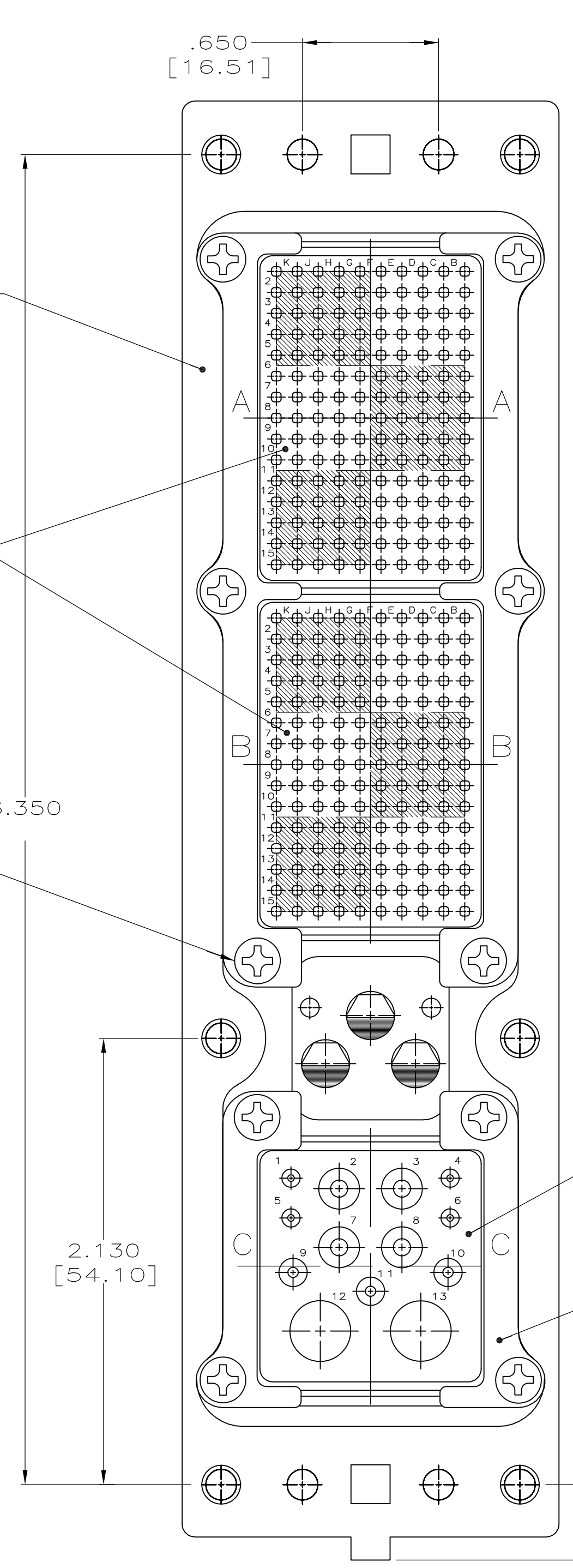

LOAD POSITIONS
1,7 & 8

SELECT LOAD DETAIL
FOR 1218049-2 ONLY
MATING FACE VIEW
X = LOADED POSITION

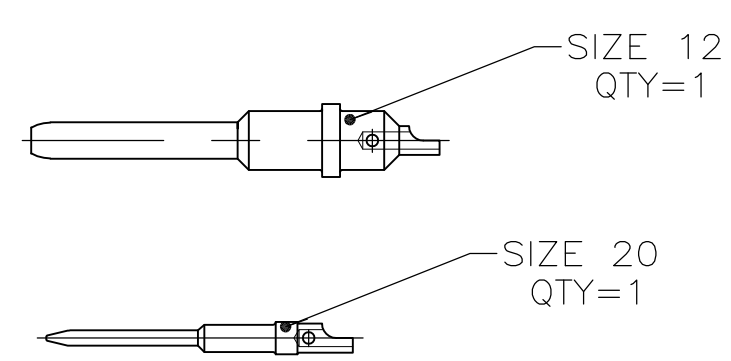

THIS DRAWING IS A CONTROLLED DOCUMENT.		DIN J.A.Baker 09-24-97		STE TE Connectivity	
DIMENSIONS: INCHES [mm]		TOLERANCES UNLESS OTHERWISE SPECIFIED:		NAME RCPT ASSY, SIZE 2, ARINC 600	
0 PLC	± -	APVD A. SHARPE	10-20-97	SIZE A1	CAGE CODE 00779
1 PLC	± -	PRODUCT SPEC		DRAWING NO. 1218049	RESTRICTED TO
2 PLC	± -	APPLICATION SPEC		SCALE 2:1	SHEET 2 OF 2
3 PLC	± .010 [0.25]	WEIGHT		REV T	
4 PLC	± -	CUSTOMER DRAWING			
ANGLES	± -				
MATERIAL SEE CALLOUTS	FINISH SEE CALLOUTS				