



Chipsmall Limited consists of a professional team with an average of over 10 year of expertise in the distribution of electronic components. Based in Hongkong, we have already established firm and mutual-benefit business relationships with customers from,Europe,America and south Asia,supplying obsolete and hard-to-find components to meet their specific needs.

With the principle of “Quality Parts,Customers Priority,Honest Operation,and Considerate Service”,our business mainly focus on the distribution of electronic components. Line cards we deal with include Microchip,ALPS,ROHM,Xilinx,Pulse,ON,Everlight and Freescale. Main products comprise IC,Modules,Potentiometer,IC Socket,Relay,Connector.Our parts cover such applications as commercial,industrial, and automotives areas.

We are looking forward to setting up business relationship with you and hope to provide you with the best service and solution. Let us make a better world for our industry!



Contact us

Tel: +86-755-8981 8866 Fax: +86-755-8427 6832

Email & Skype: info@chipsmall.com Web: www.chipsmall.com

Address: A1208, Overseas Decoration Building, #122 Zhenhua RD., Futian, Shenzhen, China



LOC	DIST	REVISIONS					
		REVISED PER	ECO	NO	DATE	BY	APPROV
D1		REVISED PER	ECO-11-005030		11MAR11	RK	HMR

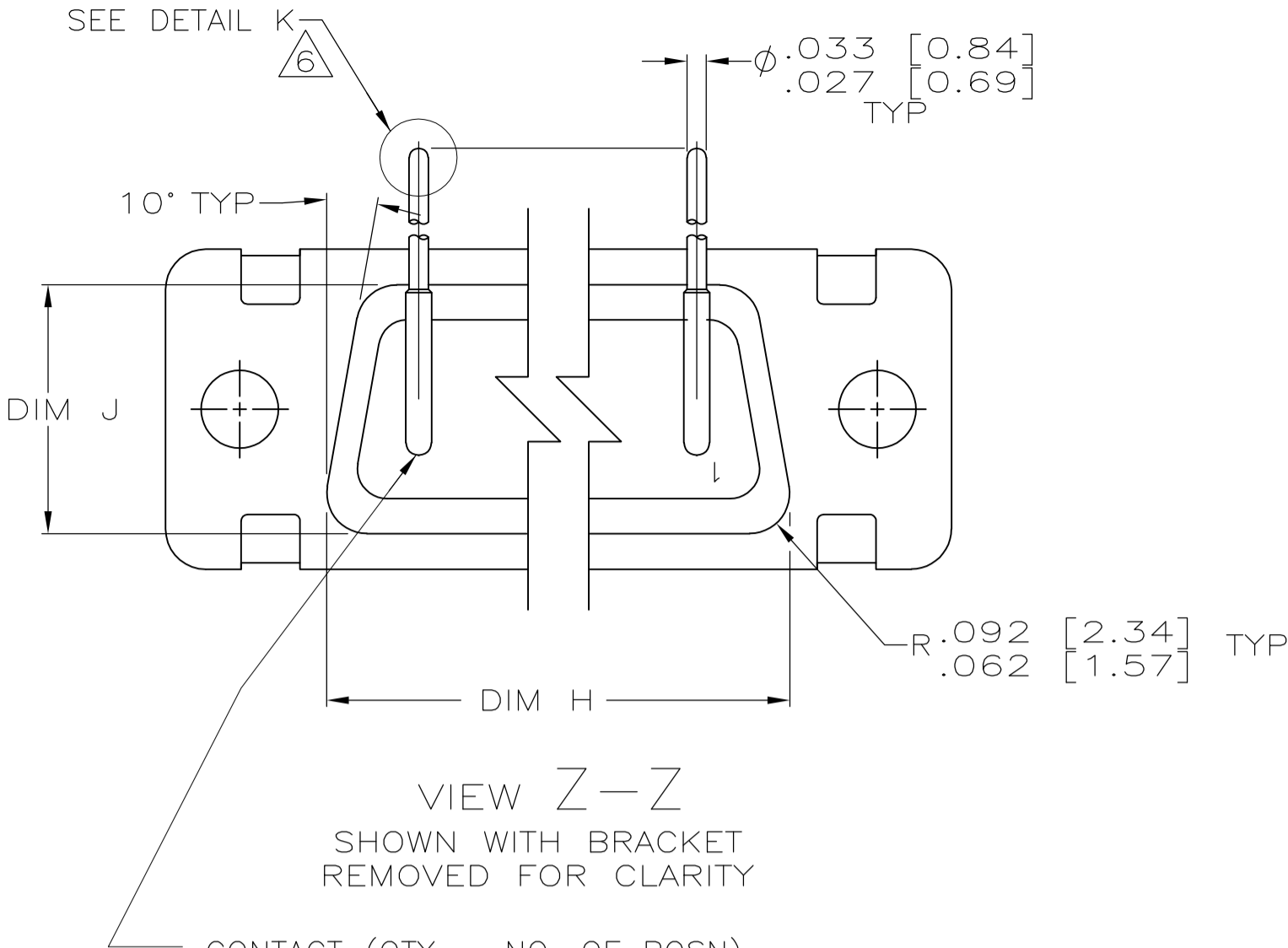
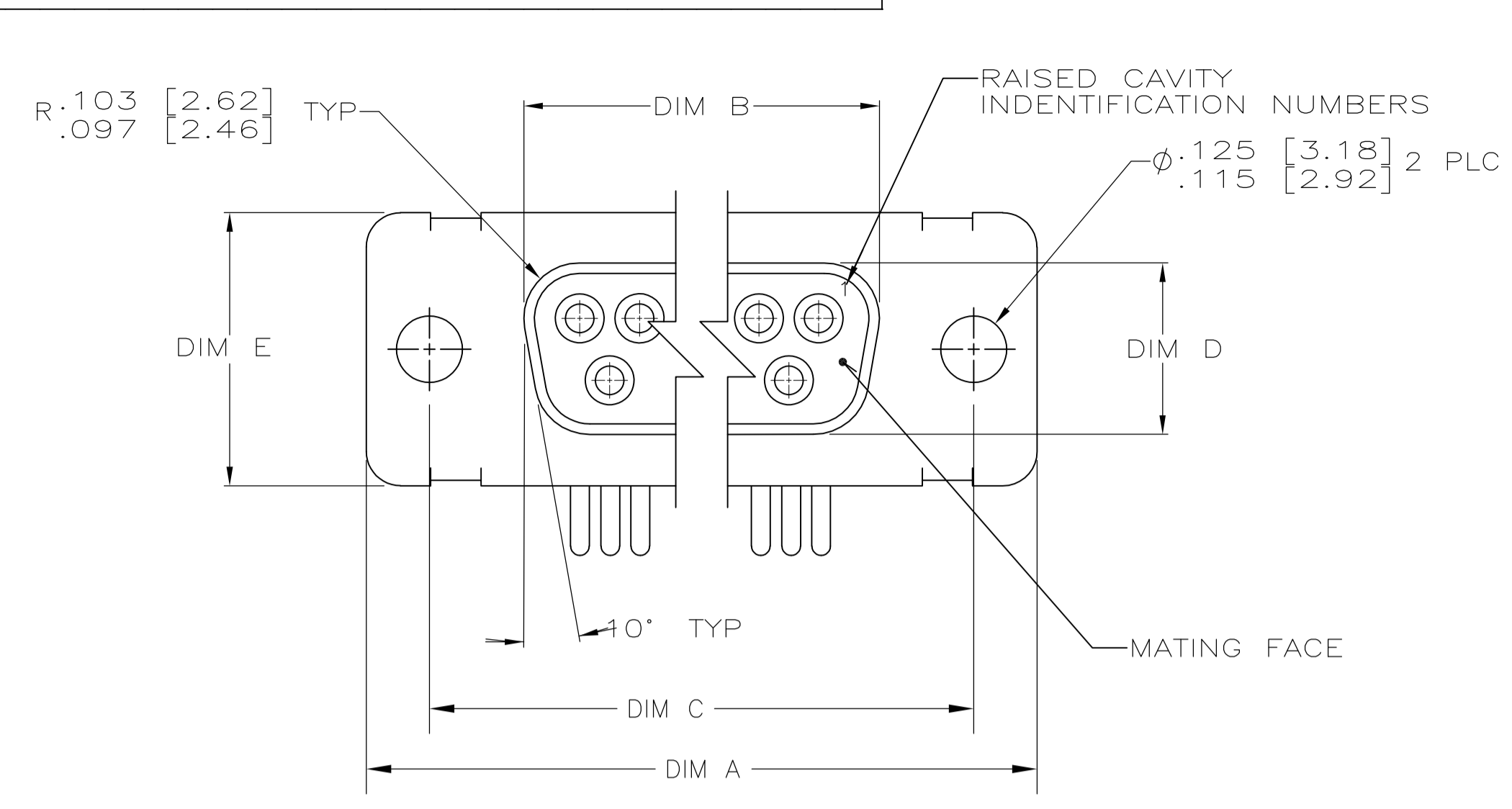

CONTACT (QTY = NO. OF POSN)
 MATL: BRASS PER ASTM-B-16, OR BERYLLIUM COPPER PER ASTM-B-194
 FINISH: GOLD PER MIL-G-45204, TYPE II, GRADE C, CLASS 1 IN CONTACT MATING AREA, .000010 [0.0003] MIN THK GOLD PER MIL-G-45204 OVER .000050 [0.0013] MIN THK NICKEL PER QQ-N-290 ON CONTACT BODY

- 1. SEE SHEET 2 FOR RECOMMENDED P.C. BOARD LAYOUT. TRUE POSITION TOLERANCE FOR P.C. BOARD LAYOUT IS .010 [0.25] AT MAX MATERIAL CONDITION. SUGGESTED BOARD THICKNESS IS .125 [3.18]
- 2. THE CONNECTORS DESCRIBED IN THIS DOCUMENT MEET THE REQUIREMENTS OF MIL-C-24308 AND MATE WITH ANY PLUG CONNECTOR WITH SAME INSERT ARRANGEMENT.
- 3. MARKED WITH .047 [1.19]-.062 [1.57] HIGH CHARACTERS. FAR SIDE REFERS TO THE WIDE SIDE OF THE KEYSTONE. NEAR SIDE REFERS TO THE NARROW SIDE OF THE KEYSTONE. IF THE REAR SHELL IS TOO SMALL FOR THE ENTIRE MILITARY PART NUMBER, MARKING SHALL BE LOCATED AS FOLLOWS:
 - A. "M24308" ON FRONT SHELL, FAR SIDE.
 - B. SLASH SHEET AND DASH NUMBER ON REAR SHELL, FAR SIDE.
 - C. "AMP" AND DATE CODE ON FRONT SHELL, NEAR SIDE.
 - D. AMP PART NUMBER ON REAR SHELL, NEAR SIDE.
- IF THE FRONT SHELL IS TOO SMALL FOR "AMP", PART NUMBER AND DATE CODE, MARKING SHALL BE SPLIT AS FOLLOWS:
 - A. PART NUMBER ON REAR SHELL, NEAR SIDE.
 - B. "AMP" AND DATE CODE ON FRONT SHELL, NEAR SIDE.
 - C. MILITARY PART NUMBER ON REAR SHELL, FAR SIDE.
- 4. POINT OF ELECTRICAL ENGAGEMENT - AS MEASURED WITH A .0390 [0.991]-.0393 [0.998] DIA SQUARE ENDED TEST PIN.
- 5. THIS DRAWING SHALL BE INTERPRETED IN ACCORDANCE WITH APPLICABLE STANDARDS LISTED IN MIL-STD-100.
- 6. SOLDER DIP PER MIL-STD-2000 COMPOSITION Sn63 CONFORMING TO QQ-S-571 IN THE ENTIRE AREA OF DIMENSION SHOWN. 1218434-6 THRU -10 ONLY.

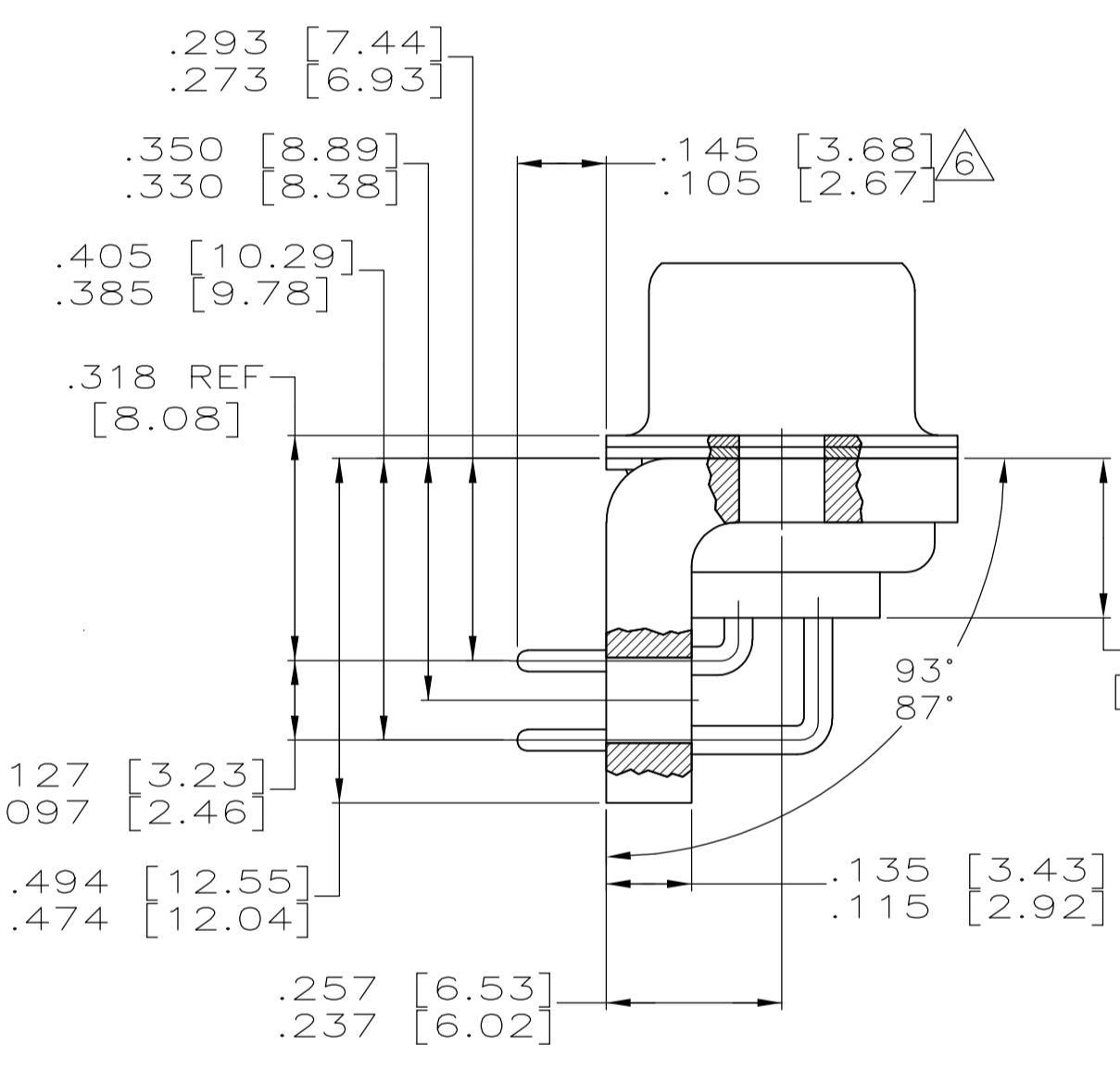
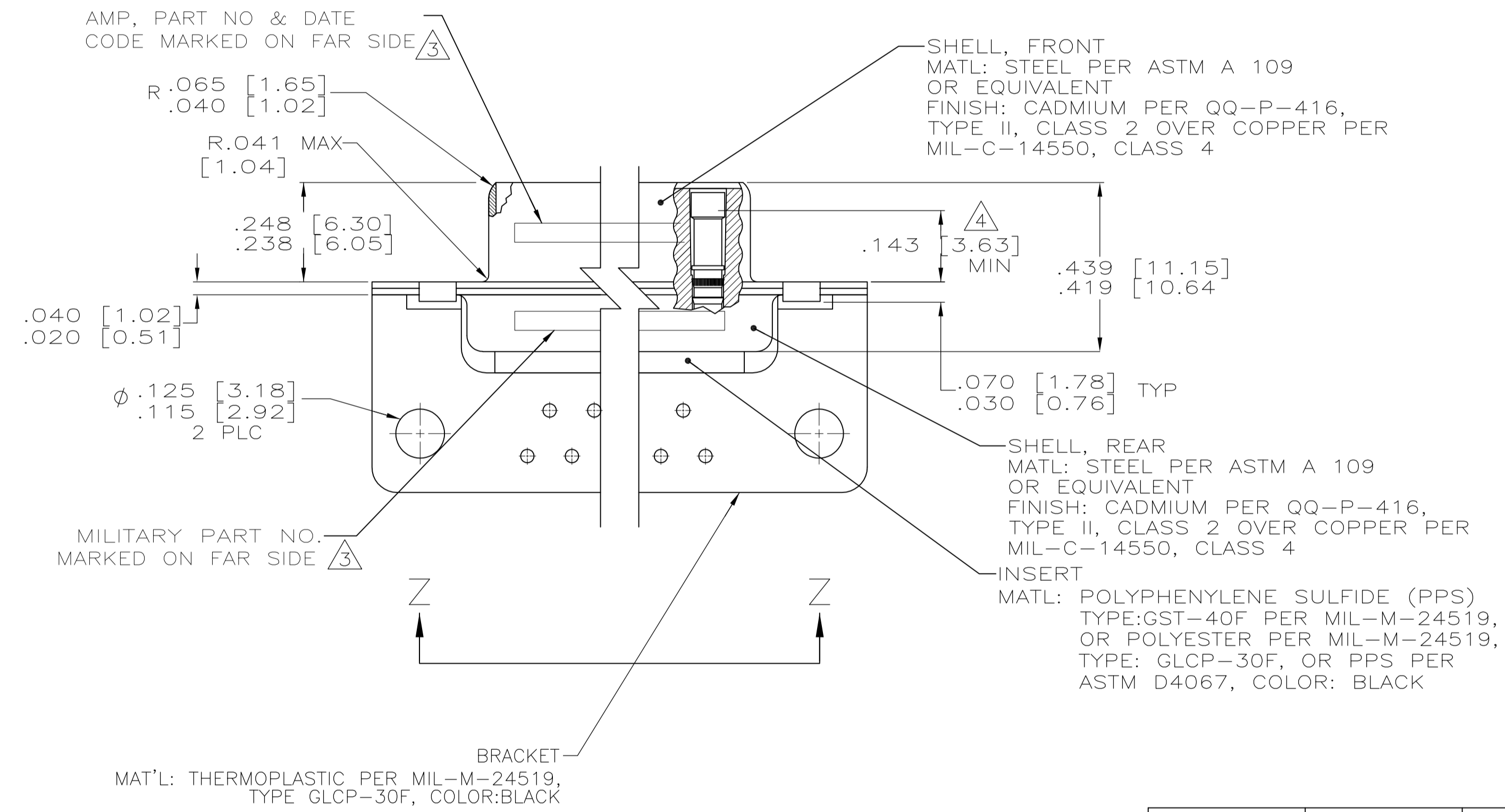

SHELL SIZES 1 THRU 4 CONTACT CONFIGURATION

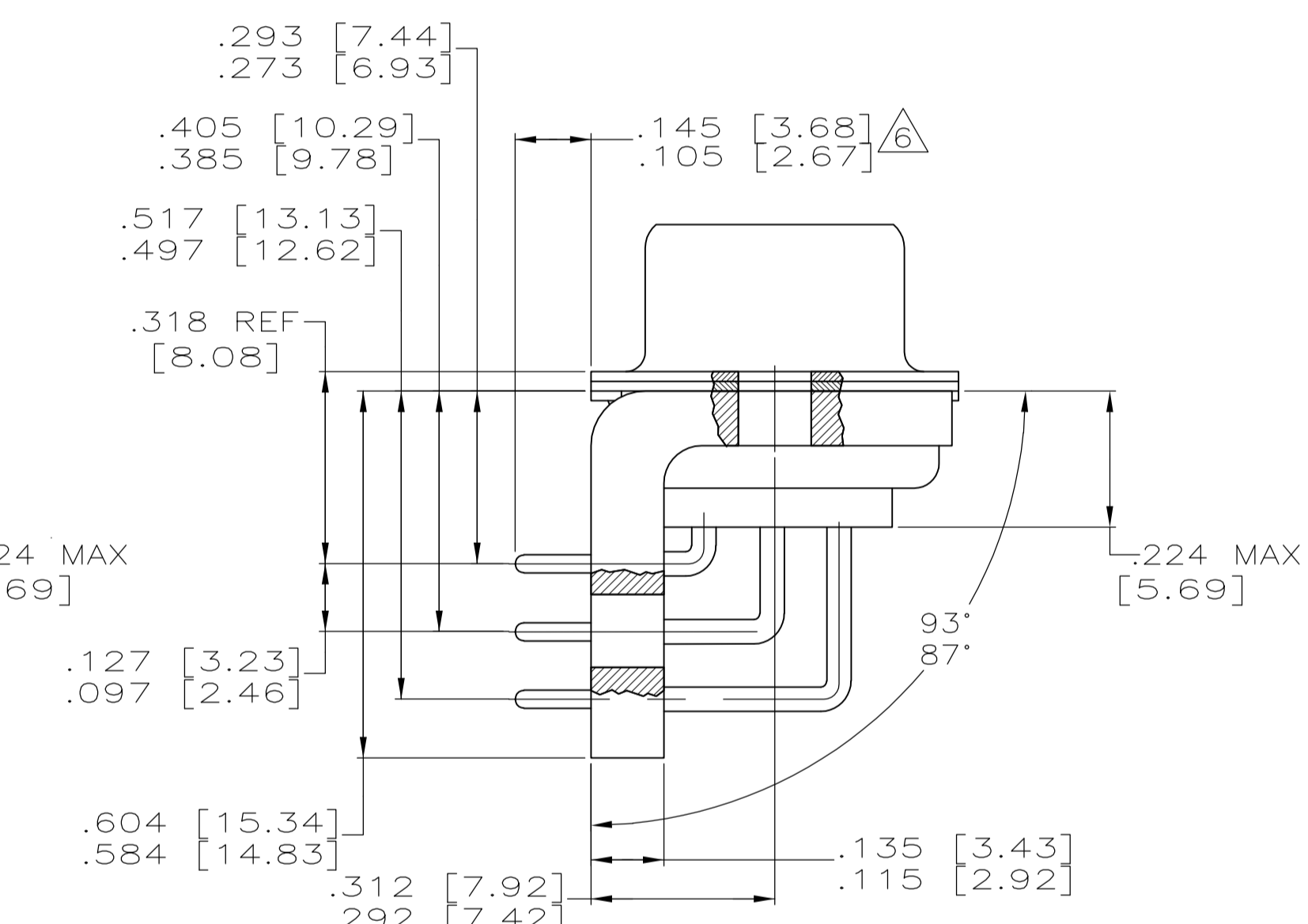

SHELL SIZE 5 CONTACT CONFIGURATION

.544 [13.82]	.2188 [55.58]	.620 [15.75]	.428 [10.87]	2.411 [61.24]	2.069 [52.55]	2.650 [67.31]
.524 [13.31]	2.168 [55.07]	.590 [14.99]	.418 [10.62]	2.401 [60.99]	2.059 [52.30]	2.620 [66.55]
.432 [10.97]	2.282 [57.96]	.509 [12.93]	.316 [8.03]	2.505 [63.63]	2.164 [54.97]	2.744 [69.70]
.412 [10.46]	2.262 [57.45]	.479 [12.17]	.306 [7.77]	2.495 [63.37]	2.154 [54.71]	2.714 [68.94]
.432 [10.97]	1.635 [41.53]	.509 [12.93]	.316 [8.03]	1.857 [47.17]	1.516 [38.51]	2.103 [53.42]
.412 [10.46]	1.615 [41.02]	.479 [12.17]	.306 [7.77]	1.847 [46.91]	1.506 [38.25]	2.073 [52.65]
.432 [10.97]	1.093 [27.76]	.509 [12.93]	.316 [8.03]	1.317 [33.45]	.976 [24.79]	1.556 [39.52]
.412 [10.46]	1.073 [27.25]	.479 [12.17]	.306 [7.77]	1.307 [33.20]	.966 [24.54]	1.526 [38.76]
.432 [10.97]	.769 [19.53]	.509 [12.93]	.316 [8.03]	.989 [25.12]	.648 [16.46]	1.228 [31.19]
.412 [10.46]	.749 [19.02]	.479 [12.17]	.306 [7.77]	.979 [24.87]	.638 [16.21]	1.198 [30.43]
.544 [13.82]	2.188 [55.58]	.620 [15.75]	.428 [10.87]	2.411 [61.24]	2.069 [52.55]	2.650 [67.31]
.524 [13.31]	2.168 [55.07]	.590 [14.99]	.418 [10.62]	2.401 [60.99]	2.059 [52.30]	2.620 [66.55]
.432 [10.97]	2.282 [57.96]	.509 [12.93]	.316 [8.03]	2.505 [63.63]	2.164 [54.97]	2.744 [69.70]
.412 [10.46]	2.262 [57.45]	.479 [12.17]	.306 [7.77]	2.495 [63.37]	2.154 [54.71]	2.714 [68.94]
.432 [10.97]	1.635 [41.53]	.509 [12.93]	.316 [8.03]	1.857 [47.17]	1.516 [38.51]	2.103 [53.42]
.412 [10.46]	1.615 [41.02]	.479 [12.17]	.306 [7.77]	1.847 [46.91]	1.506 [38.25]	2.073 [52.65]
.432 [10.97]	1.093 [27.76]	.509 [12.93]	.316 [8.03]	1.317 [33.45]	.976 [24.79]	1.556 [39.52]
.412 [10.46]	1.073 [27.25]	.479 [12.17]	.306 [7.77]	1.307 [33.20]	.966 [24.54]	1.526 [38.76]
.432 [10.97]	.769 [19.53]	.509 [12.93]	.316 [8.03]	.989 [25.12]	.648 [16.46]	1.228 [31.19]
.412 [10.46]	.749 [19.02]	.479 [12.17]	.306 [7.77]	.979 [24.87]	.638 [16.21]	1.198 [30.43]

DIM J	DIM H	DIM E	DIM D	DIM C	DIM B	DIM A	INSERT ARRANGEMENT	NO OF POS	SHELL SIZE	MILITARY P/N ON CONNECTOR	P/N MARKED ON CONNECTOR	PART NO.
50	5	5	M24308/23-29F	1218434-5	1-1218434-0							
37	4	4	M24308/23-28F	1218434-4	1218434-9							
25	3	3	M24308/23-27F	1218434-3	1218434-8							
15	2	2	M24308/23-26F	1218434-2	1218434-7							
9	1	1	M24308/23-25F	1218434-1	1218434-6							
50	5	5	M24308/23-29F	1218434-5	1218434-5							
37	4	4	M24308/23-28F	1218434-4	1218434-4							
25	3	3	M24308/23-27F	1218434-3	1218434-3							
15	2	2	M24308/23-26F	1218434-2	1218434-2							
9	1	1	M24308/23-25F	1218434-1	1218434-1							

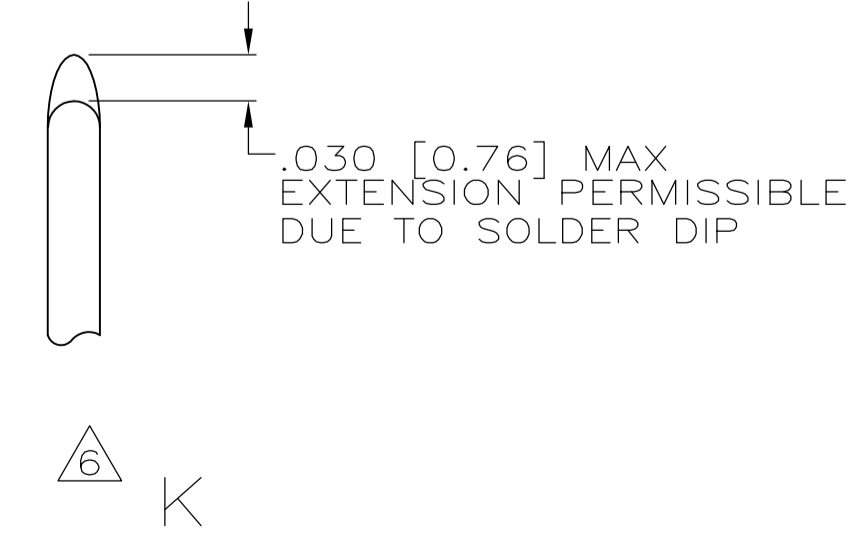

THIS DRAWING IS A CONTROLLED DOCUMENT.

DIMENSIONS: INCHES	TOLERANCES UNLESS OTHERWISE SPECIFIED:	DIN C.C. THOMAS 12-3-99	TE Connectivity
0 PLC ± -	1 PLC ± -	12-15-99	
2 PLC ± -	3 PLC ± -		
4 PLC ± -	ANGLES ± 1°		

MATERIAL: THERMOPLASTIC PER MIL-M-24519, TYPE GLCP-30F, COLOR: BLACK

FINISH: SEE CALLOUTS

WEIGHT: -

CUSTOMER DRAWING

SCALE: 4:1

SHEET 1 OF 2

REV D1

APPROVED: CHAD BAKER

DATE: 12-15-99

NAME: CHAD BAKER

PRODUCT SPEC: RECEPTACLE ASSY, AMPLIMITE RIGHT ANGLE, SERIES 109 SIZES 1 THRU 5

SIZE: A1

CAGE CODE: 00779

DRAWING NO: 1218434

RESTRICTED TO: -

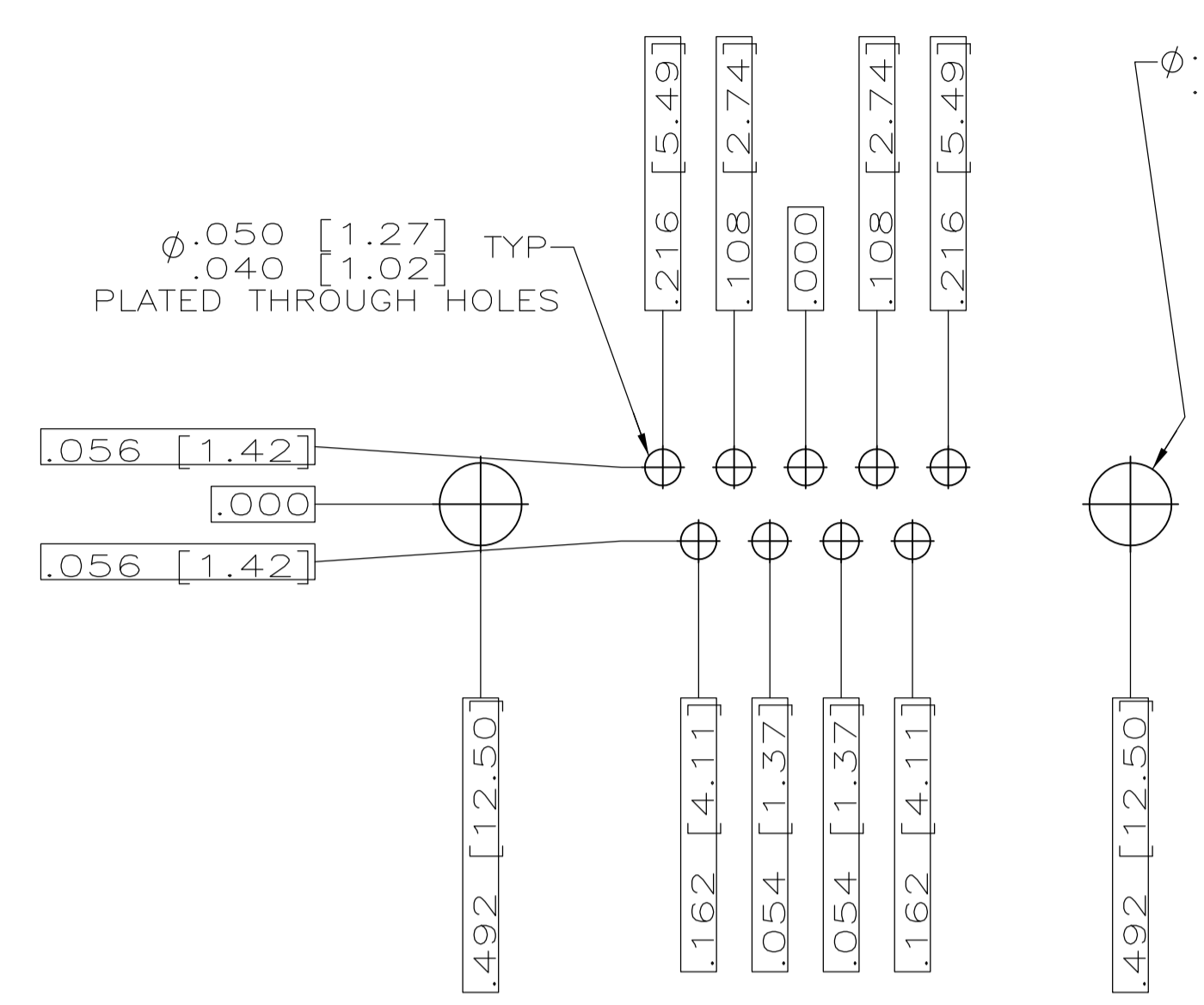

RECOMMENDED P.C. BOARD LAYOUT
SHELL SIZE 1 (9 POSITION)

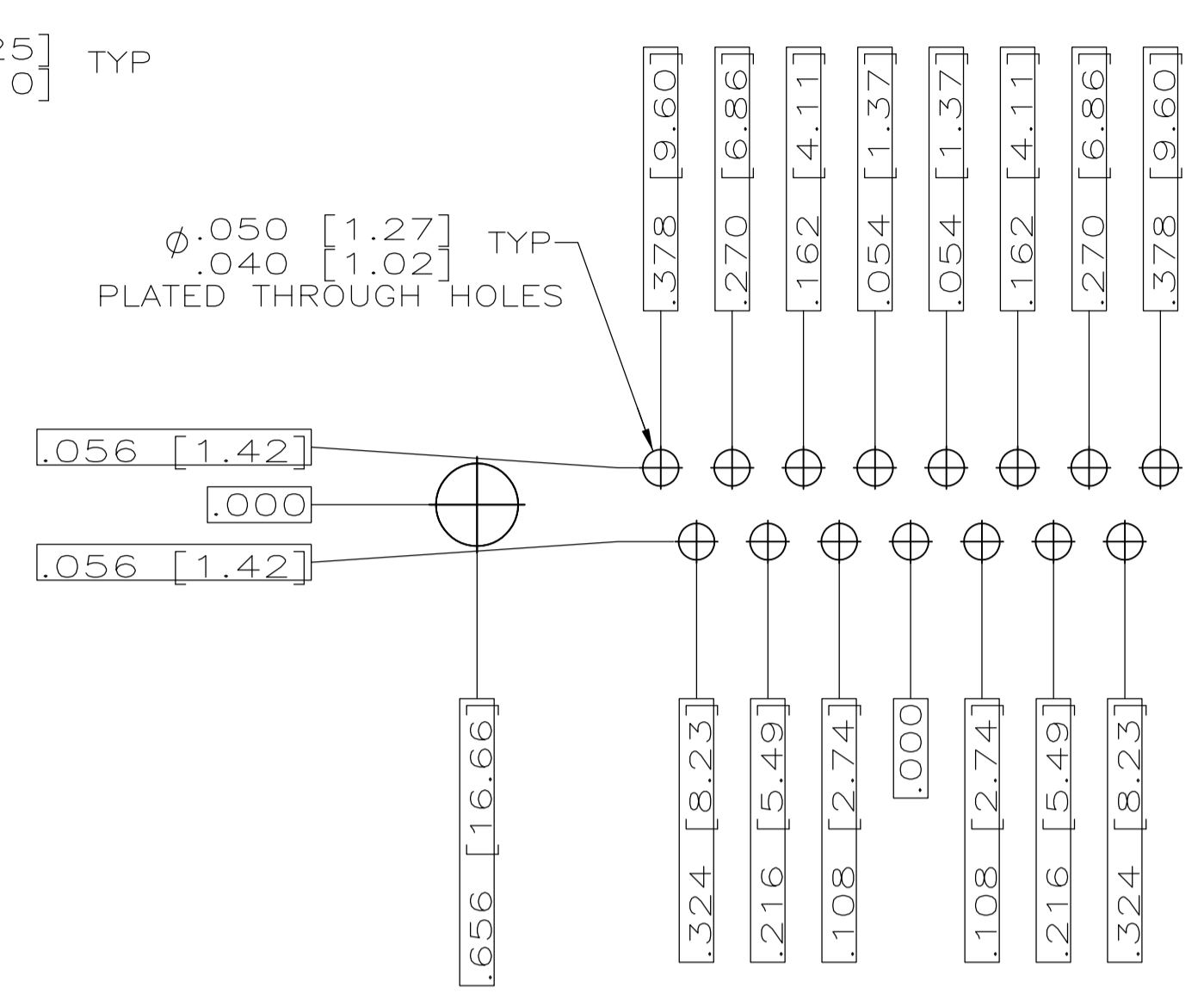

RECOMMENDED P.C. BOARD LAYOUT
SHELL SIZE 2 (15 POSITION)

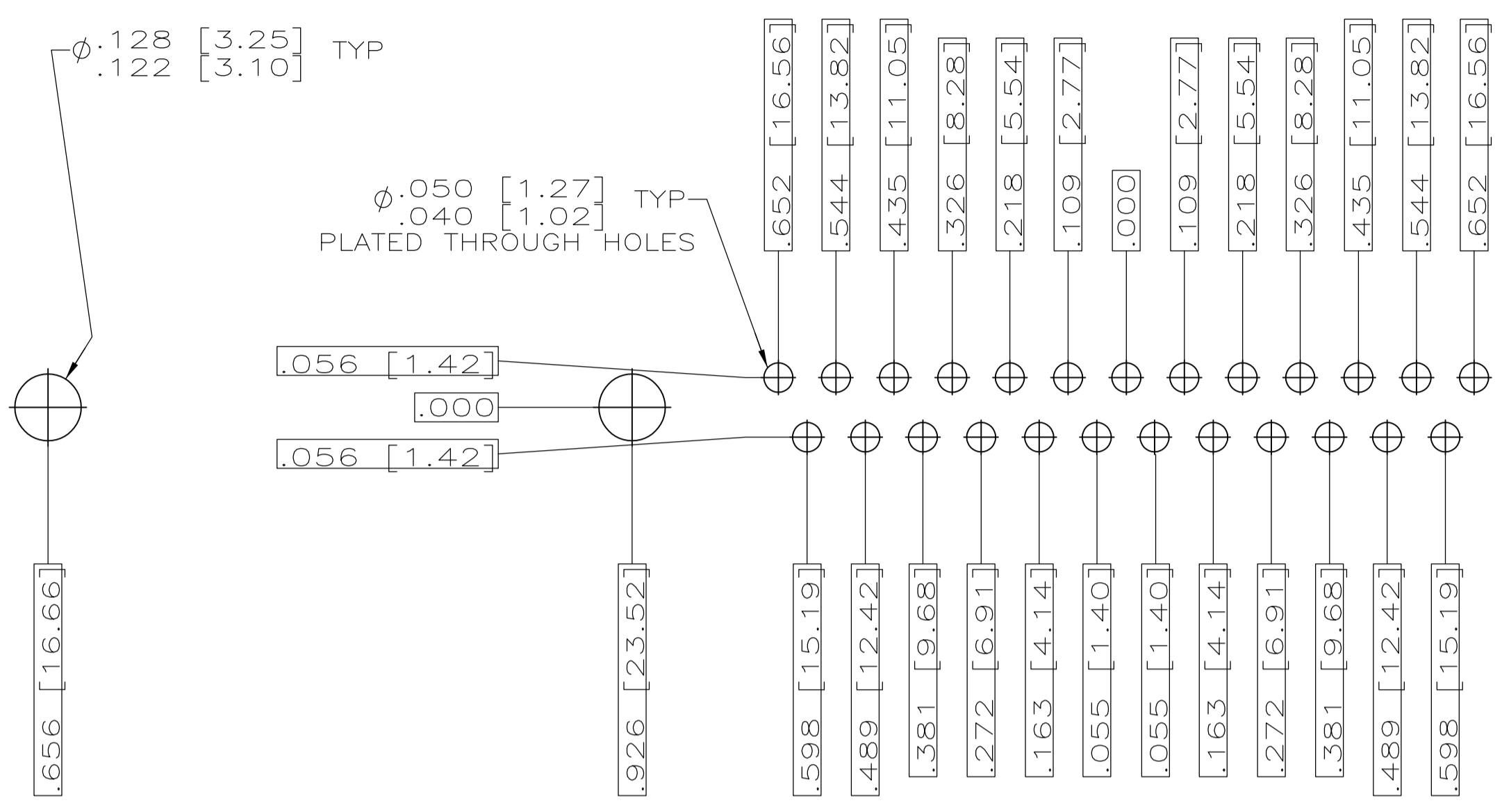

RECOMMENDED P.C. BOARD LAYOUT
SHELL SIZE 3 (25 POSITION)

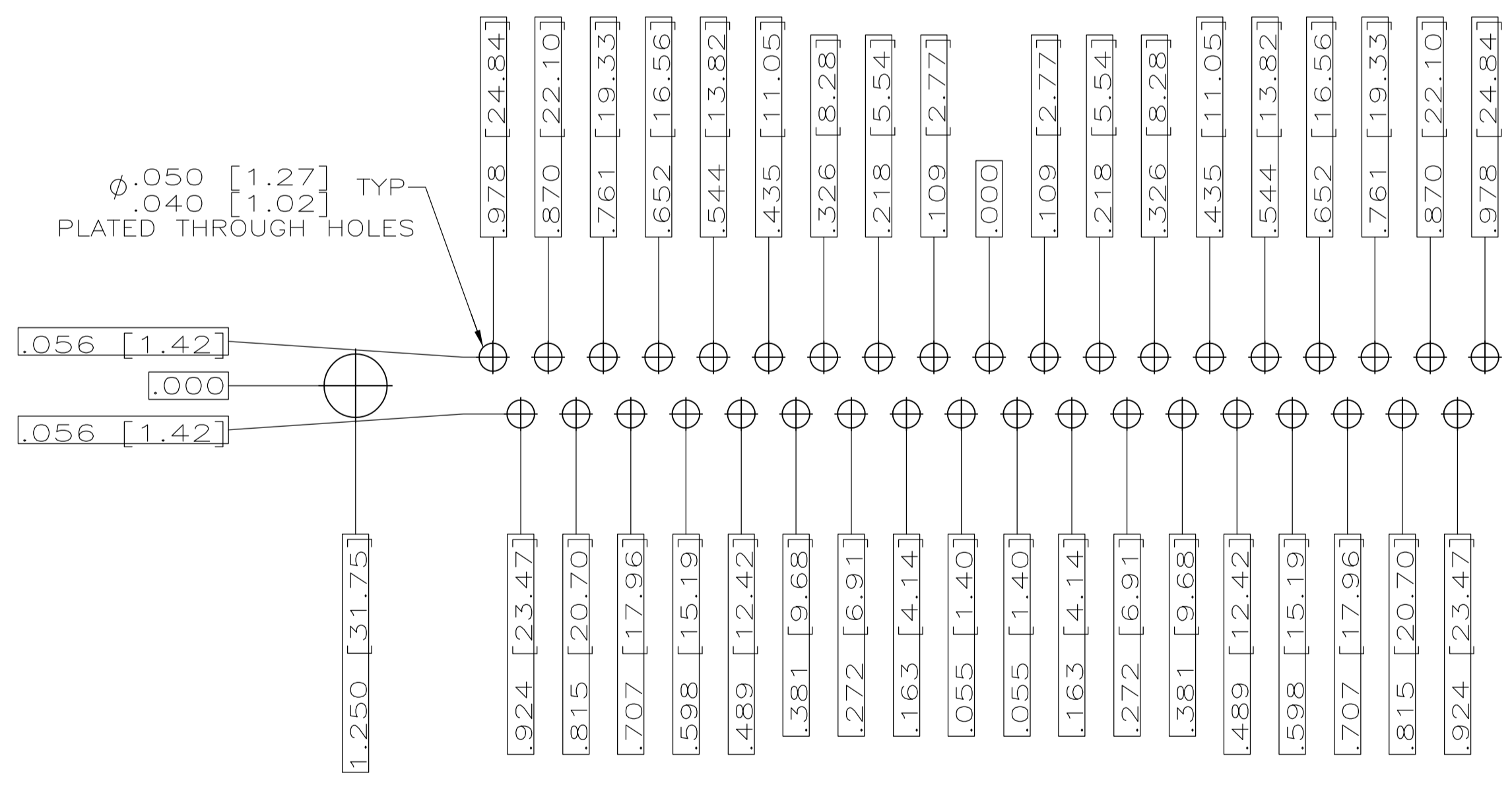

RECOMMENDED P.C. BOARD LAYOUT
SHELL SIZE 4 (37 POSITION)

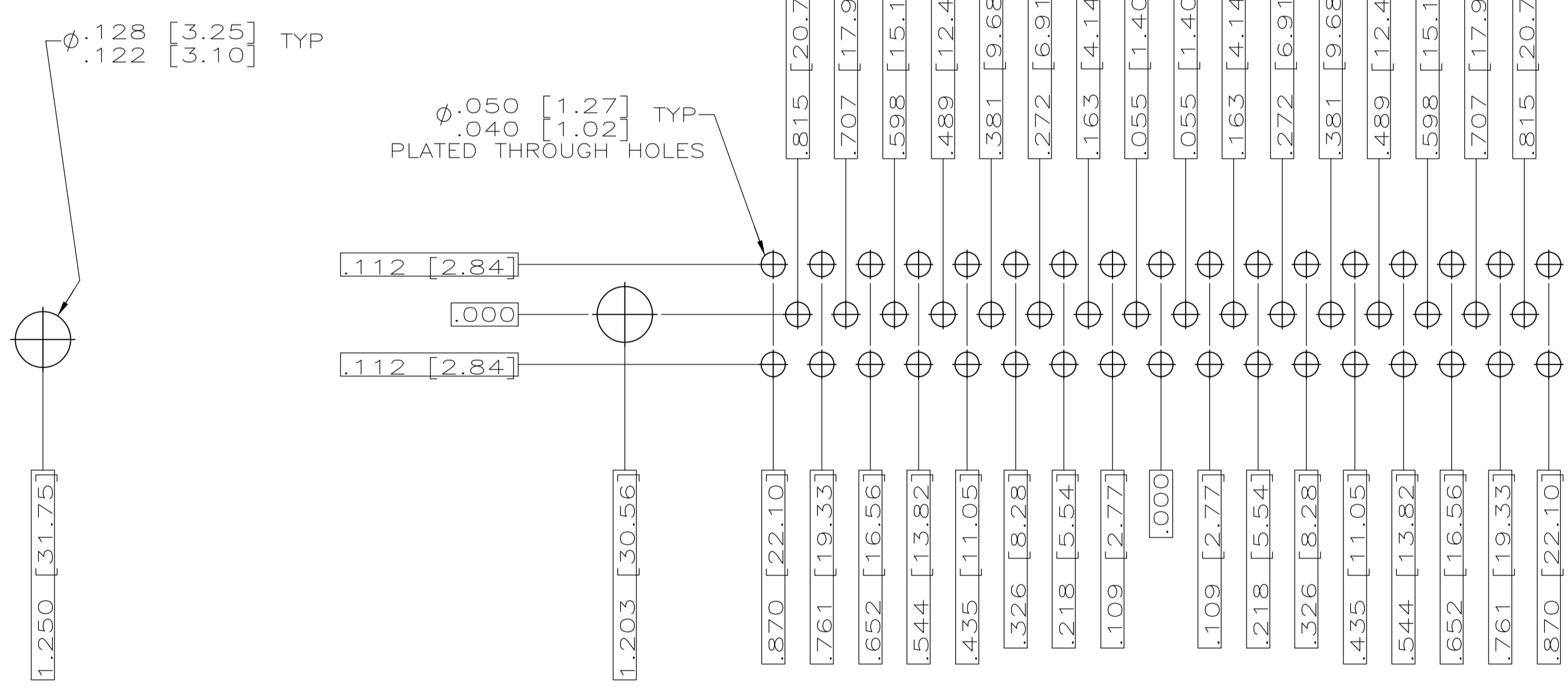

RECOMMENDED P.C. BOARD LAYOUT
SHELL SIZE 5 (50 POSITION) Δ

THIS DRAWING IS A CONTROLLED DOCUMENT.		DIN C.C.THOMAS 12-3-99	 TE Connectivity
DIMENSIONS: INCHES		CHK CHAD BAKER 12-15-99	
TOLERANCES UNLESS OTHERWISE SPECIFIED: 0 PLC ± .001 1 PLC ± .001 2 PLC ± .001 3 PLC ± .001 4 PLC ± .010 (0.25) ANGLES ± .4°		APVD CHAD BAKER 12-15-99	NAME RECEPTACLE ASSY,AMPLIMITE RIGHT ANGLE,SERIES 109,SIZE 1 THRU 5
MATERIAL SEE CALLOUTS		FINISH SEE CALLOUTS	RESTRICTED TO SIZE A1 00779 C=1218434
CUSTOMER DRAWING		SCALE 4:1	SHEET 2 OF 2 REV D1