



Chipsmall Limited consists of a professional team with an average of over 10 year of expertise in the distribution of electronic components. Based in Hongkong, we have already established firm and mutual-benefit business relationships with customers from,Europe,America and south Asia,supplying obsolete and hard-to-find components to meet their specific needs.

With the principle of “Quality Parts,Customers Priority,Honest Operation,and Considerate Service”,our business mainly focus on the distribution of electronic components. Line cards we deal with include Microchip,ALPS,ROHM,Xilinx,Pulse,ON,Everlight and Freescale. Main products comprise IC,Modules,Potentiometer,IC Socket,Relay,Connector.Our parts cover such applications as commercial,industrial, and automotives areas.

We are looking forward to setting up business relationship with you and hope to provide you with the best service and solution. Let us make a better world for our industry!



Contact us

Tel: +86-755-8981 8866 Fax: +86-755-8427 6832

Email & Skype: info@chipsmall.com Web: www.chipsmall.com

Address: A1208, Overseas Decoration Building, #122 Zhenhua RD., Futian, Shenzhen, China



b) Technical specification:

Technische Daten:

Working voltage/
Betriebsspannung: 250 V AC

Initial contact
resistance/
Anfangs-
Durchgangswiderstand: $\leq 20 \text{ m}\Omega$

Temperature range/
Temperaturbereich: $-55 \text{ }^\circ\text{C} \dots +125 \text{ }^\circ\text{C}$

Mating cycles/
Steckzyklen: Quality class 1 = 500
Gütestufe 1
Quality class 2 = 400
Gütestufe 2
Quality class 3 = 50
Gütestufe 3

**Materials/
Werkstoffe:**

Contact/
Kontakt: Cu alloy, Au over Ni



Insulator/
Isolierkörper: PBT GF UL 94 V-0, grey/grau

**Installation specification/
Montagedaten:**

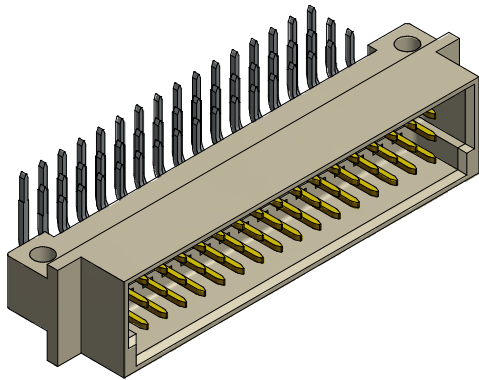
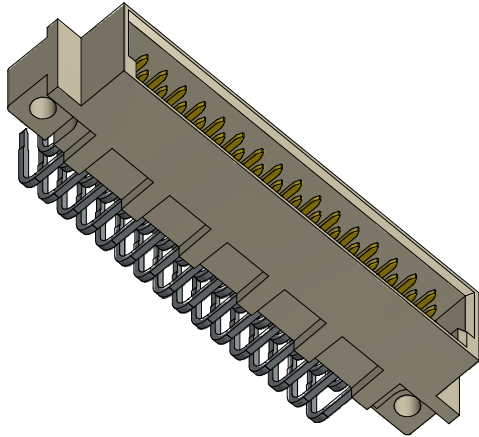
PCB-Hole drillings/
Leiterplattenbohrbild: see Sheet 2/
siehe Seite 2



b) Part no. / Part marked / Art.-Nr. / Bedruckung:	Quality class / Gütestufe:	Contact plating / Kontakt Veredelung:
121A10389X	3	Gold over nickel / 50 mating cycles Gold über Nickel / 50 Steckzyklen
121B10389X	2	Gold over nickel / 400 mating cycles Gold über Nickel / 400 Steckzyklen
121C10389X	1	Gold over nickel / 500 mating cycles Gold über Nickel / 500 Steckzyklen

		 dim. in mm	Male Connector Type "C 1/2" 48 pos. Solder pin angled Messerleiste Type "C 1/2" 48 pol. Lötstift abgewinkelt		
		Date/Datum			Name
		drawn/ gez. 05.01.07			Lehmenkühler
		appd./ gepr. 05.01.07	Mickenbecker		
Index: b Ä6547 24.02.2017 L.U.	scale/Maßstab: 2:1			dwg no / Z.-nr.: 12K1A457	DIN- A3
Status: InBearbeitung					1 / 2
RoHS compliant/konform					

The reproduction, distribution and utilization of this document as well as the communication of its content to others without express authorization is prohibited. Offenders will be held liable for the payment of damages. Wir bitten Sie, die Weitergabe, Verbreitung und Nutzung dieses Dokuments, sowie die Kommunikation seiner Inhalte an Dritte ohne ausdrückliche Genehmigung der Schmalz AG, zu vermeiden.

