



Chipsmall Limited consists of a professional team with an average of over 10 year of expertise in the distribution of electronic components. Based in Hongkong, we have already established firm and mutual-benefit business relationships with customers from,Europe,America and south Asia,supplying obsolete and hard-to-find components to meet their specific needs.

With the principle of “Quality Parts,Customers Priority,Honest Operation,and Considerate Service”,our business mainly focus on the distribution of electronic components. Line cards we deal with include Microchip,ALPS,ROHM,Xilinx,Pulse,ON,Everlight and Freescale. Main products comprise IC,Modules,Potentiometer,IC Socket,Relay,Connector.Our parts cover such applications as commercial,industrial, and automotives areas.

We are looking forward to setting up business relationship with you and hope to provide you with the best service and solution. Let us make a better world for our industry!



Contact us

Tel: +86-755-8981 8866 Fax: +86-755-8427 6832

Email & Skype: info@chipsmall.com Web: www.chipsmall.com

Address: A1208, Overseas Decoration Building, #122 Zhenhua RD., Futian, Shenzhen, China



This document is the property of Amphenol Corporation and is delivered on the express condition that it is not to be disclosed, reproduced or used, in whole or in part, for manufacture or sale by anyone other than Amphenol Corporation without its prior consent, & that no right is granted to disclose or to use any information in this document.

REFERENCE DRAWING

REVISIONS				
SYM	ECN	DESCRIPTION	DATE	APPROVED
X1	1504****	NEW RELEASE	04/24/15	Tom
X2	1602****	UPDATE	02/25/16	Tom
X3	1609****	UPDATE	09/06/16	Tom

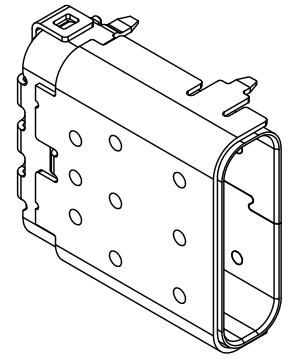
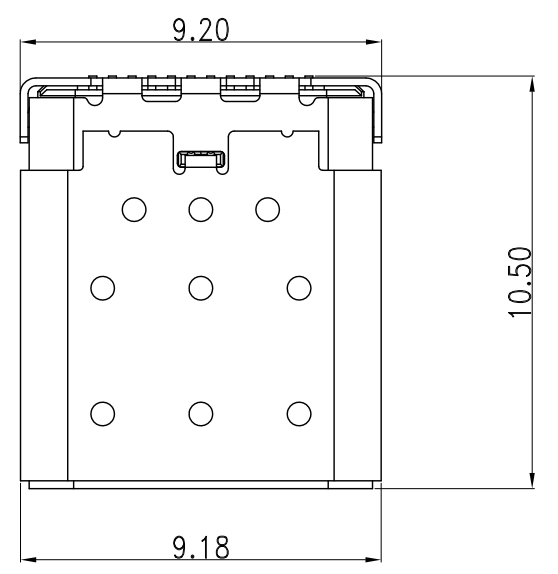

Pin No	Signal Name	Mating Sequence	Pin No	Signal Name	Mating Sequence
A1	GND	First	B12	GND	First
A2	TX1+	Second	B11	RX1+	Second
A3	TX1-	Second	B10	RX1-	Second
A4	VBUS	First	B9	VBUS	First
A5	CC1	Second	B8	SBU2	Second
A6	D+	Second	B7	D-	Second
A7	D-	Second	B6	D+	Second
A8	SBU1	Second	B5	CC2	Second
A9	VBUS	First	B4	VBUS	First
A10	RX2-	Second	B3	TX2-	Second
A11	RX2+	Second	B2	TX2+	Second
A12	GND	First	B1	GND	First
SHELL	GND		SHELL	GND	

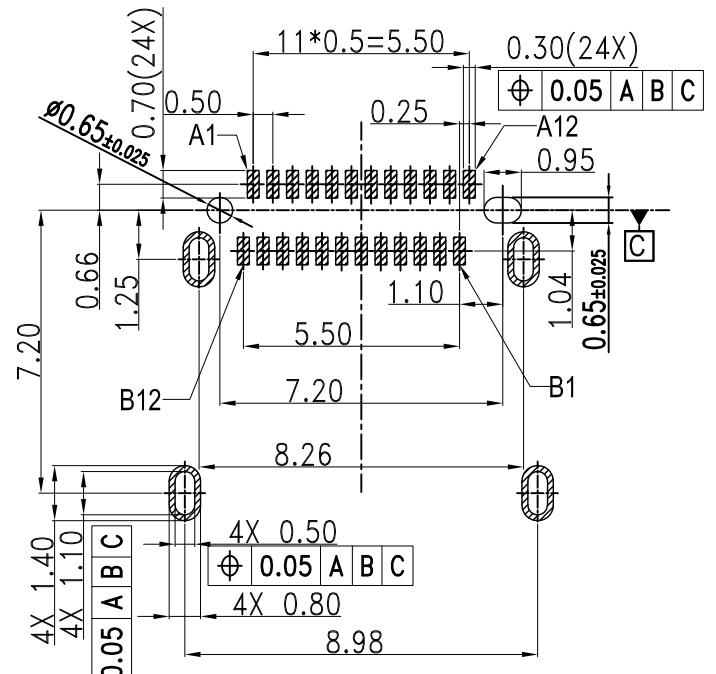
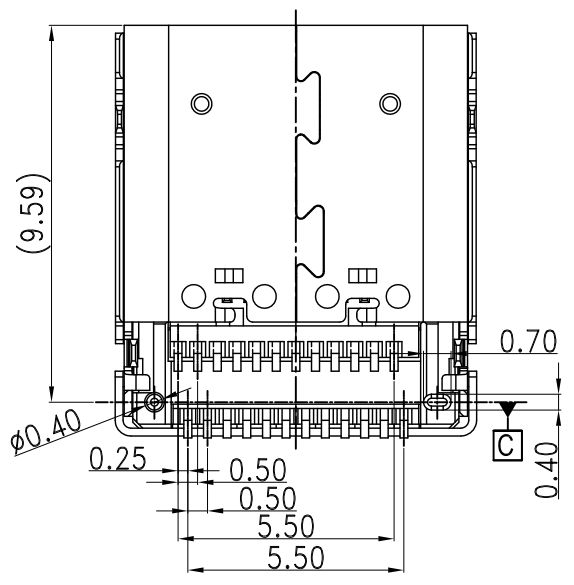
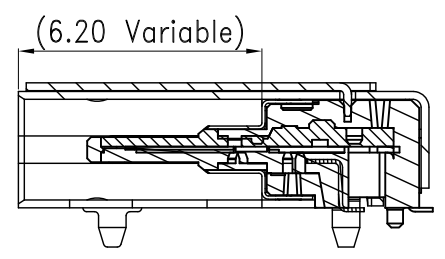
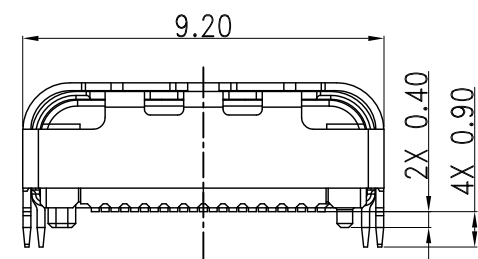
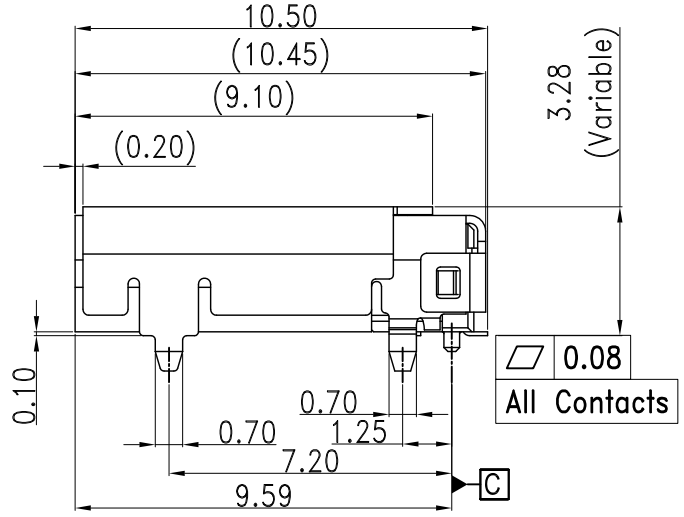
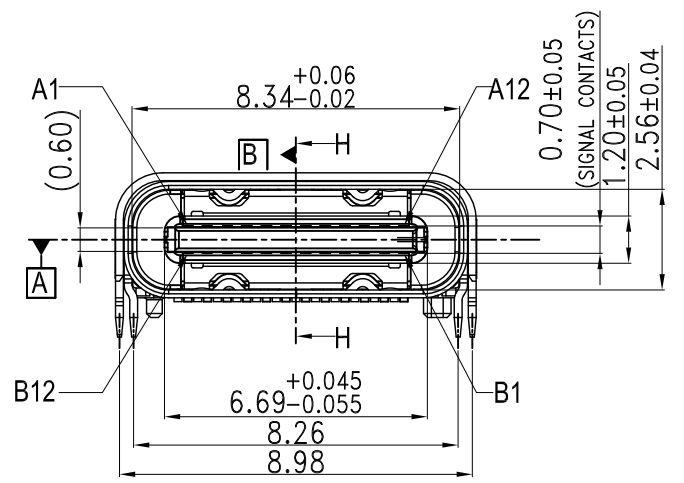

RECOMMENDED PCB LAYOUT (Tolerance=±0.05)

Notes:

- Material :
Contacts : copper alloy
Shell : Stainless steel.
Housing : High-temperature polymer UL94V-0, black.
- Plating :
Contacts: contact area 30u" Au, Solder tail gold flash or matte tin, nickel overall.
Shell : Nickel Plating
- Coplanarity : 0.08Max.
- P/N : 12401610E4#2A.
- Packaging type: carrier tape.
- Material should be fulfilled Amphenol spec# SSN002 AND Customer Requirements, for halogen free products, also need to meet SSN004

UNLESS OTHERWISE SPECIFIED TOLERANCES		APPROVAL	DATE	<h2>Amphenol</h2>
.X	+/-	DRAWN	09/06/16	
.XX	+/-	CHECKED	09/06/16	
FOR MATERIALS AND FINISHES SEE NOTES		DRAWING FILE :		TITLE
REMOVE SHARP EDGES		ANGLE OF PROJECTION		USB TYPE C CONNECTOR RIGHT ANGLE DUAL ROW SMT
DIMENSIONS		SIZE		DRAWING NO.
U.S.	INCHES	A3		12401610E4#2A
(METRIC)	(MM)	SCALE		REV. X3
		NONE		SHEET 1 OF 1