



Chipsmall Limited consists of a professional team with an average of over 10 year of expertise in the distribution of electronic components. Based in Hongkong, we have already established firm and mutual-benefit business relationships with customers from,Europe,America and south Asia,supplying obsolete and hard-to-find components to meet their specific needs.

With the principle of "Quality Parts,Customers Priority,Honest Operation,and Considerate Service",our business mainly focus on the distribution of electronic components. Line cards we deal with include Microchip,ALPS,ROHM,Xilinx,Pulse,ON,Everlight and Freescale. Main products comprise IC,Modules,Potentiometer,IC Socket,Relay,Connector.Our parts cover such applications as commercial,industrial, and automotives areas.

We are looking forward to setting up business relationship with you and hope to provide you with the best service and solution. Let us make a better world for our industry!



## Contact us

Tel: +86-755-8981 8866 Fax: +86-755-8427 6832

Email & Skype: info@chipsmall.com Web: www.chipsmall.com

Address: A1208, Overseas Decoration Building, #122 Zhenhua RD., Futian, Shenzhen, China



This document is the property of Amphenol Corporation and is delivered on the express condition that it is not to be disclosed, reproduced or used, in whole or in part, for manufacture or sale by anyone other than Amphenol Corporation without its prior consent, & that no right is granted to disclose or to use any information in this document.

# REFERENCE DRAWING

		REVISIONS		
SYM	ECN	DESCRIPTION	DATE	APPROVED
X1	1605****	NEW RELEASE	04/25/17	Tom

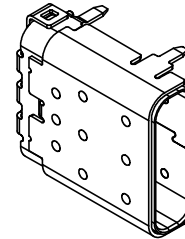
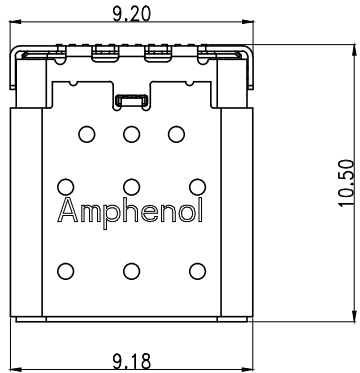

Pin No	Signal Name	Mating Sequence	Pin No	Signal Name	Mating Sequence
A1	GND	First	B12	GND	First
A2	TX1+	Second	B11	RX1+	Second
A3	TX1-	Second	B10	RX1-	Second
A4	Vbus	First	B9	Vbus	First
A5	CC1	Second	B8	SBU2	Second
A6	D+	Second	B7	D-	Second
A7	D-	Second	B6	D+	Second
A8	SBU1	Second	B5	CC2	Second
A9	Vbus	First	B4	Vbus	First
A10	RX2-	Second	B3	TX2-	Second
A11	RX2+	Second	B2	TX2+	Second
A12	GND	First	B1	GND	First
SHELL	GND		SHELL	GND	

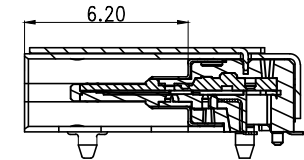
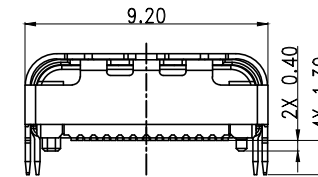
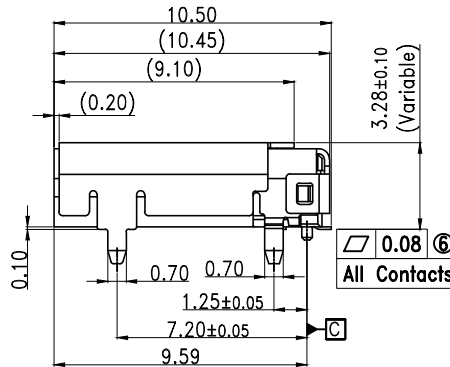
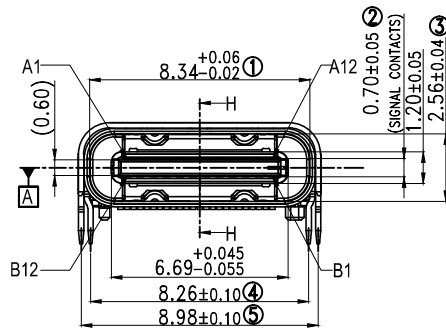

SECTION H-H

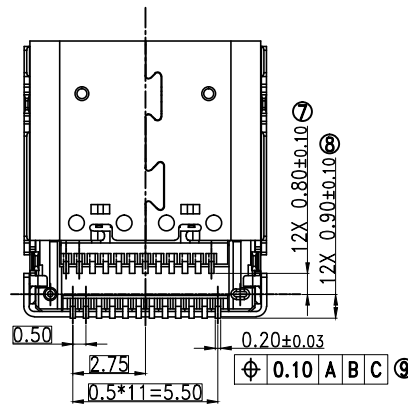
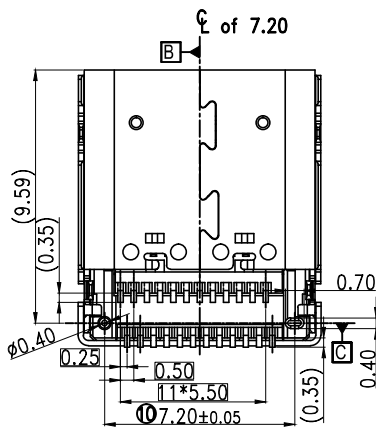

Notes:

- Material :  
Contacts : copper alloy  
Shell : Stainless steel.  
Housing : High-temperature polymer UL94V-0, black.
- Plating :  
Contacts: contact area 30u" Au, Solder tail gold flash or matte tin, nickel overall.  
Shell : Nickel Plating
- Coplanarity : 0.08Max.
- P/N : 12401722E4#2A.
- Packaging type: carrier tape.
- Material should be fulfilled Amphenol spec# SSN002  
AND Customer Requirements, for halogen free products,  
also need to meet SSN004

UNLESS OTHERWISE SPECIFIED TOLERANCES		APPROVAL	DATE	Amphenol
.X	+/-	DRAWN	04/25/17	
.XX	+/-	CHECKED	04/25/17	
.XXX	+/-	CHECKED		
FRACTIONS +/-		DRAWING FILE :		TITLE USB TYPE C CONNECTOR RIGHT ANGLE DUAL ROW SMT(S=1.30mm)
ANGLES +/-		ANGLE OF PROJECTION		
FOR MATERIALS AND FINISHES SEE NOTES		REMOVE SHARP EDGES		SIZE
DIMENSIONS		DIMENSIONS		DRAWING NO.
U.S.	INCHES	U.S. INCHES		A3
(METRIC)	(MM)	(METRIC) (MM)		12401832E402A
SCALE		NONE		REV. X1
SHEET 1 OF 2				

This document is the property of Amphenol Corporation and is delivered to the recipient under license. It is not to be distributed, reproduced or used, in whole or in part, without the prior written consent of Amphenol Corporation. All rights reserved. A hard or soft copy is prohibited or otherwise restricted in any way without the prior written consent of Amphenol Corporation or its authorized representatives. In the absence of such consent, the recipient shall be liable for any damages or losses caused by the use of this document.

REV. 1	DESCRIPTION	DATE	APPROVED
SYM	ECH		

SEE PAGE 1

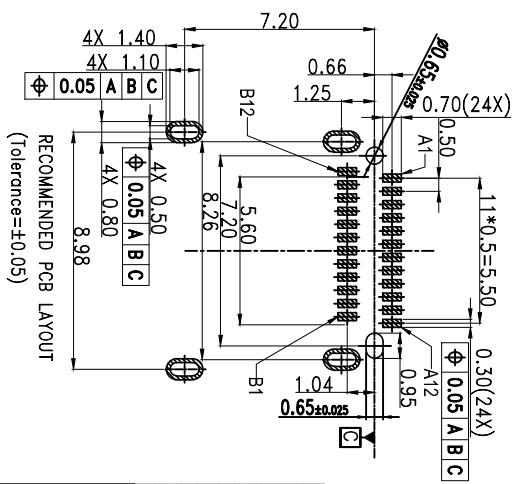
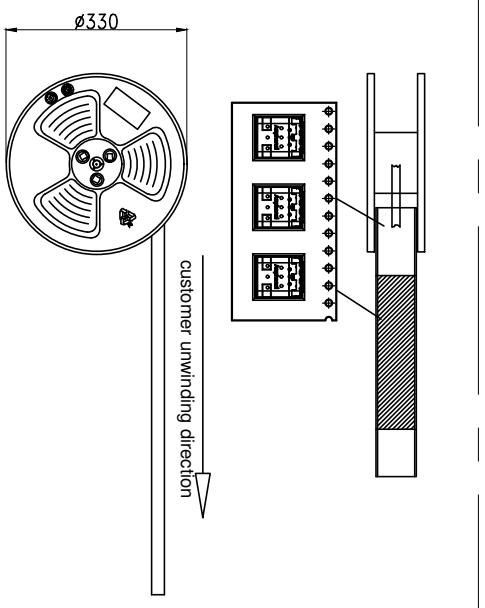
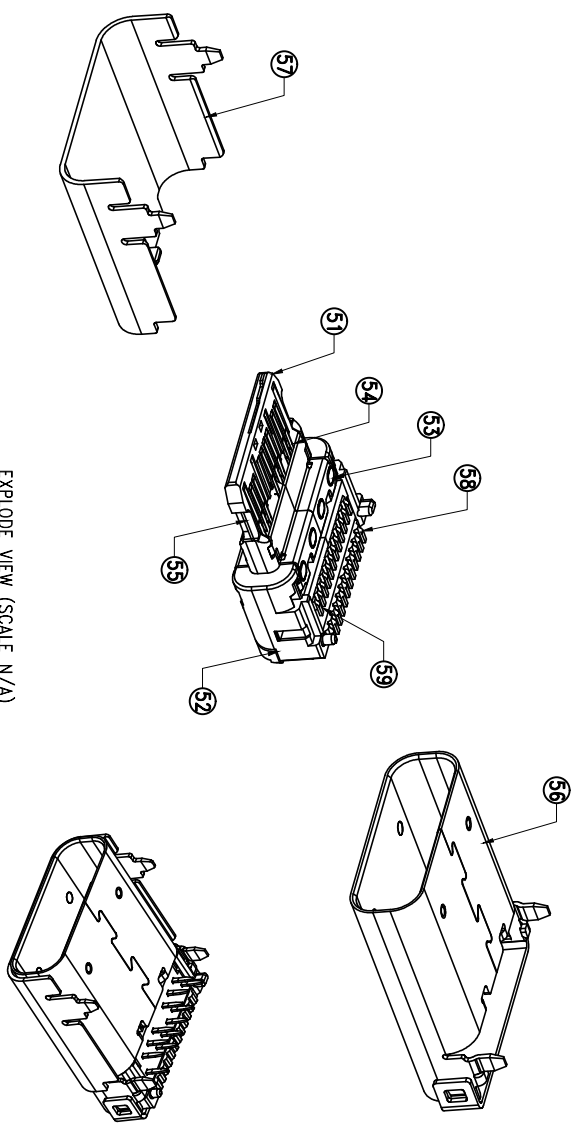

ITEM	DESCRIPTION	QTY	MATERIAL	PART NO.	FINISH
1	MAIN HOUSING	1	PA46	8240012002A	BLACK
2	ENC SHEET	1	SUS304-1/2H	3240184846	SOLDER NICKEL: 500" MIN
3	ENC SHEET	1	SUS301-EH	3240184746	SOLDER NICKEL: 500" MIN
4	MAIN SHELL	1	SUS304-1/2H	3240184853	SOLDER NICKEL: 500" MIN
5	OUTER SHELL	1	SUS304-1/2H	3240183163	SOLDER NICKEL: 500" MIN
6	TOP TERMINAL	1	C7025 TMO3	3240184854	CONTACT:50μ AU MIN; SOLDER TAIL:100μ WASTE TIN MIN;
7	BOTTOM TERMINAL	1	C7025 TMO3	3240184854	CONTACT:50μ AU MIN; SOLDER TAIL:100μ WASTE TIN MIN;

UNLESS OTHERWISE SPECIFIED		APPROVAL	
TOLERANCES	U.S. METRIC	DRAWN	Almond
		CHECKED	Wahidulla
		CHECKED	

FOR MATERIALS AND FINISHES		DRAWING FILE 1	
SEE NOTES		ANGLE OF PROJECTION	
REMOVE SHARP EDGES			
DIMENSIONS			
U.S.	INCHES		
(ACTING)	(MM)		



Amphenol

TITLE  
USB TYPE C CONNECTOR RIGHT ANGLE DUAL ROW SMT(S=1.30mm)

SIZE: DRAWING NO. A3 12401832E402A  
SCALE: NONE SHEET 2 OF 2  
REV. X1