



Chipsmall Limited consists of a professional team with an average of over 10 year of expertise in the distribution of electronic components. Based in Hongkong, we have already established firm and mutual-benefit business relationships with customers from,Europe,America and south Asia,supplying obsolete and hard-to-find components to meet their specific needs.

With the principle of “Quality Parts,Customers Priority,Honest Operation,and Considerate Service”,our business mainly focus on the distribution of electronic components. Line cards we deal with include Microchip,ALPS,ROHM,Xilinx,Pulse,ON,Everlight and Freescale. Main products comprise IC,Modules,Potentiometer,IC Socket,Relay,Connector.Our parts cover such applications as commercial,industrial, and automotives areas.

We are looking forward to setting up business relationship with you and hope to provide you with the best service and solution. Let us make a better world for our industry!



## Contact us

Tel: +86-755-8981 8866 Fax: +86-755-8427 6832

Email & Skype: info@chipsmall.com Web: www.chipsmall.com

Address: A1208, Overseas Decoration Building, #122 Zhenhua RD., Futian, Shenzhen, China



a) Part as supplied

203W301-\*G02

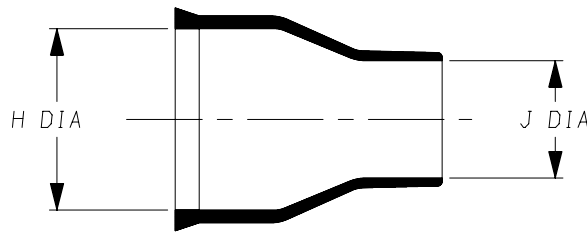

b) Part after unrestricted recovery

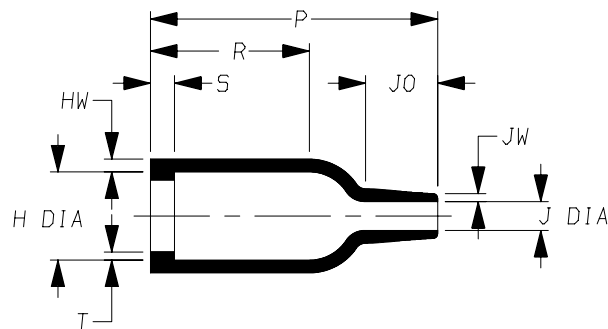

**DIMENSIONS** in millimetres  
(in inches, for reference)

Part No.	H		J		P	R	S	T	JO	HW	JW
	Min	Max	Min	Max	±10%	±10%	±10%	±10%	±10%	±20%	±20%
	a	b	a	b	b	b	b	b	b	b	b
203W301-*G02	10 (0.39)	5.8 (0.23)	6.0 (0.24)	2.2 (0.09)	19 [0.75]	11 [0.43]	1.5 (0.06)	0.5 (0.02)	4.5 (0.18)	0.8 (0.03)	0.5 (0.02)
			#		#	#	#				

This is a trimmed and expanded variant  
Modified dimensions are shown thus:- #

Copyright (!)

The copyright in this drawing is the property of Tyco Electronics UK Ltd. The drawing is issued on the condition that it is not copied, reproduced or disclosed to a third party, either in whole or in part without the prior written consent of Tyco Electronics UK Ltd.

Drawn A.LILLEY. Checked

Issue 1

Date July 2008

Conforms to ISO Recommendations

Approval  
Design

MKTG.

Tech.

3rd Angle Projection  
Not to Scale

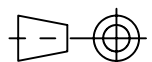

<b>Raychem</b>		<b>Specification Control Drawing</b>	Part Number 203W301-*G02 Issue 1
Iss.	Date	E.C.R. No.	Details of Change

### (Ordering Information)

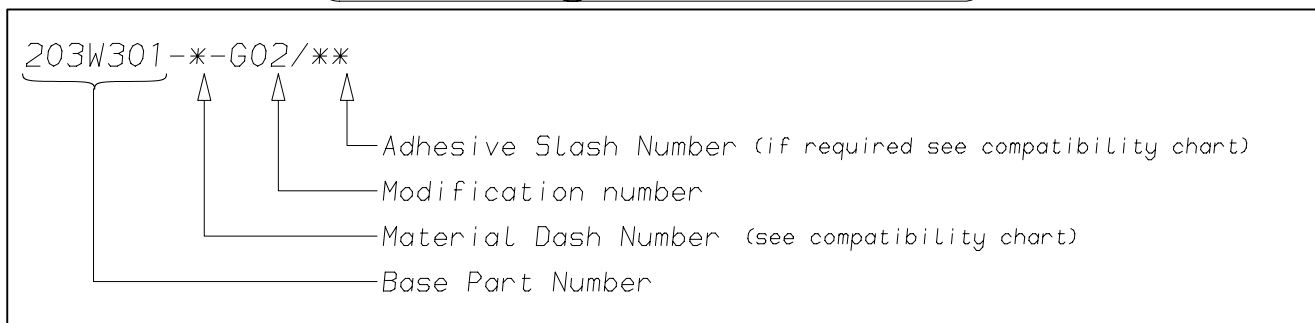

### (COMPATIBILITY CHART)

Material Dash Number	Material Description	SPEC Number	Coating Slash Number
-3	POLYOLEFIN, SEMI-RIGID	RT-301	/42, /86, /180
-4	POLYOLEFIN, FLEXIBLE	RT-1304	/42, /86, /180
-25	ELASTOMER, FLUID RESISTANT	RW-2070	/42, /86, /225
-130	POLYOLEFIN, COMMERCIAL FLEXIBLE	RW-2008	/42

### NOTES

- ① As supplied dimensions are for uncoated parts, when coating is added entry diameters will reduce by 1.5mm Max.

Tyco Electronics UK Ltd. Faraday Road, Swindon, Wiltshire, SN3 5HH England Telephone: (01793) 528171 Fax: 572516	Tyco Electronics Corporation 300, Constitution Drive, Menlo Park, CA 94025 USA Telephone (650) 361-3860 Fax: (650) 361-5579
Cage Code K1010	Cage Code 06090