



Chipsmall Limited consists of a professional team with an average of over 10 year of expertise in the distribution of electronic components. Based in Hongkong, we have already established firm and mutual-benefit business relationships with customers from,Europe,America and south Asia,supplying obsolete and hard-to-find components to meet their specific needs.

With the principle of “Quality Parts,Customers Priority,Honest Operation,and Considerate Service”,our business mainly focus on the distribution of electronic components. Line cards we deal with include Microchip,ALPS,ROHM,Xilinx,Pulse,ON,Everlight and Freescale. Main products comprise IC,Modules,Potentiometer,IC Socket,Relay,Connector.Our parts cover such applications as commercial,industrial, and automotives areas.

We are looking forward to setting up business relationship with you and hope to provide you with the best service and solution. Let us make a better world for our industry!



Contact us

Tel: +86-755-8981 8866 Fax: +86-755-8427 6832

Email & Skype: info@chipsmall.com Web: www.chipsmall.com

Address: A1208, Overseas Decoration Building, #122 Zhenhua RD., Futian, Shenzhen, China



inspired LED

12V Flexible LED Strip Lights

Normal Bright Single Color



Inspired LED's **12 Volt Single Color Flexible Strip Lights** are an ideal solution for creating festive lighting displays in both homes and businesses. Available in custom lengths or 12 meter reels, these unique strips can easily be cut and terminated with solderless end connectors for quick DIY installation. Energy efficient, long lasting, and dimmable with compatible systems, Inspired LED flex strips are the perfect option for any lighting application!

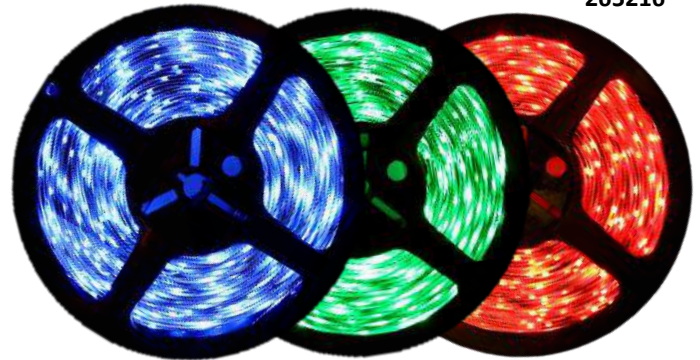

Specifications:

| | Voltage | LED Density | Wattage | Radiant Power (brightness) | Peak Wavelength |
|---------------------|---------|-----------------------|-------------|----------------------------|-----------------|
| Normal Bright Blue | 12V | 9 LEDs/ft., 30 LEDs/m | ~0.80 W/ft. | ~0.275 W/ft. | 465 nm |
| Normal Bright Green | 12V | 9 LEDs/ft., 30 LEDs/m | ~0.75 W/ft. | ~0.100 W/ft. | 517 nm |
| Normal Bright Red | 12V | 9 LEDs/ft., 30 LEDs/m | ~0.70 W/ft. | ~0.070 W/ft. | 630 nm |

Product Features:

- Size 2835 diodes , 1.31" between each LED
- 8mm flex, cut points available every 3.82" (3 LEDs)
- Available in custom pre-cut lengths or full 12m reels
- Class 2 DC plug-in connectors (3.5 x 1.3 mm) or screw terminal end connectors available
- Adhesive mounting to almost any flat surface
- Minimal heat production, no IR or UV output
- Dimmable with compatible systems
- Rated to last up to 100,000 hours
- CSA C22.2 No. 250.0-08/ANSI/UL Standard 1598, 8750
- **To be installed in accordance with NEC, using Class 2 12V power supply only!**

Product Dimensions:

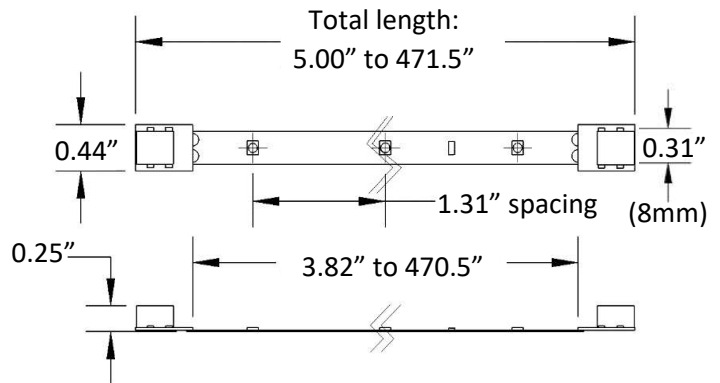

*Dimensions show in inches

Power Requirements:

| Power Source | Max Length |
|------------------|-----------------|
| 1 Amp (12 W) | 174" (10 W) |
| 2 Amp (24 W) | 347.5" (21.5 W) |
| 40W Transformer | 580.5" (36W) |
| 3.8 Amp (45.6 W) | 662" (41W) |
| 5 Amp (60 W) | 871" (54W) |
| 60W Transformer | 871" (54W) |
| 100W Transformer | 1451.5" (90W) |
| 150W Transformer | 2177.5" (135W) |

*70% brightness at 339.5". Longer strips should be powered from center to avoid further voltage drop.

Installation Instructions:

1. Clean desired mounting surface(s) and test all products prior to installation.
2. Temporarily mount LED flex strips using scotch or painters tape.
3. Connect LED strips with compatible interconnect cables or 16-22 AWG wire.
4. Run cable from LED system to control device and 12V Class 2 power source (see diagrams below for more detail).
5. Test lighting system. When satisfied with placement, peel adhesive backing from components and press firmly to adhere to surface.

Plug-in System

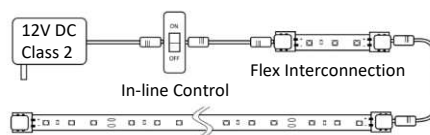

Hardwire System

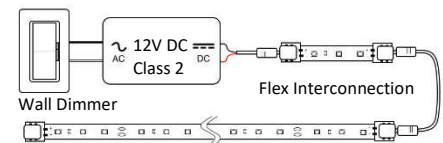

inspiredled.com



orders@inspiredled.com



(480) 941-4286