



Chipsmall Limited consists of a professional team with an average of over 10 year of expertise in the distribution of electronic components. Based in Hongkong, we have already established firm and mutual-benefit business relationships with customers from,Europe,America and south Asia,supplying obsolete and hard-to-find components to meet their specific needs.

With the principle of "Quality Parts,Customers Priority,Honest Operation,and Considerate Service",our business mainly focus on the distribution of electronic components. Line cards we deal with include Microchip,ALPS,ROHM,Xilinx,Pulse,ON,Everlight and Freescale. Main products comprise IC,Modules,Potentiometer,IC Socket,Relay,Connector.Our parts cover such applications as commercial,industrial, and automotives areas.

We are looking forward to setting up business relationship with you and hope to provide you with the best service and solution. Let us make a better world for our industry!



Contact us

Tel: +86-755-8981 8866 Fax: +86-755-8427 6832

Email & Skype: info@chipsmall.com Web: www.chipsmall.com

Address: A1208, Overseas Decoration Building, #122 Zhenhua RD., Futian, Shenzhen, China



PART NUMBER	ITEM ① BODY	ITEM ② BASE	ITEM ③ CONTACT (ONE PIECE)	ITEM ④ INSULATOR	ITEM ⑤ INSULATOR	ITEM ⑥ WASHER	ITEM ⑦ NUT
131-3701-341	BRASS GOLD PL .00001 MIN OVER NICKEL PL .00005 MIN OVER COPPER PL .00005 MIN	BRASS GOLD PL .00001 MIN OVER NICKEL PL .00005 MIN OVER COPPER PL .00005 MIN	BRASS GOLD PL .00003 MIN OVER NICKEL PL .00005 MIN OVER COPPER PL .00005 MIN	TEFLON	TEFLON	PHOSPHOR BRONZE GOLD PL .00001 MIN OVER NICKEL PL .00005 MIN OVER COPPER PL .00005 MIN	BRASS GOLD PL .00001 MIN OVER NICKEL PL .00005 MIN OVER COPPER PL .00005 MIN
131-3701-342	BRASS GOLD PL .00001 MIN OVER NICKEL PL .00005 MIN OVER COPPER PL .00005 MIN	BRASS GOLD PL .00001 MIN OVER NICKEL PL .00005 MIN OVER COPPER PL .00005 MIN	BRASS GOLD PL .00003 MIN OVER NICKEL PL .00005 MIN OVER COPPER PL .00005 MIN	TEFLON	TEFLON		BRASS (QTY-2) GOLD PL .00001 MIN OVER NICKEL PL .00005 MIN OVER COPPER PL .00005 MIN
131-3701-343	BRASS GOLD PL .00001 MIN OVER NICKEL PL .00005 MIN OVER COPPER PL .00005 MIN	BRASS GOLD PL .00001 MIN OVER NICKEL PL .00005 MIN OVER COPPER PL .00005 MIN	BRASS GOLD PL .00003 MIN OVER NICKEL PL .00005 MIN OVER COPPER PL .00005 MIN	TEFLON	TEFLON	PHOSPHOR BRONZE (QTY-2) GOLD PL .00001 MIN OVER NICKEL PL .00005 MIN OVER COPPER PL .00005 MIN	BRASS (QTY-2) GOLD PL .00001 MIN OVER NICKEL PL .00005 MIN OVER COPPER PL .00005 MIN
131-3701-344	BRASS GOLD PL .00001 MIN OVER NICKEL PL .00005 MIN OVER COPPER PL .00005 MIN	BRASS GOLD PL .00001 MIN OVER NICKEL PL .00005 MIN OVER COPPER PL .00005 MIN	BRASS GOLD PL .00003 MIN OVER NICKEL PL .00005 MIN OVER COPPER PL .00005 MIN	TEFLON	TEFLON		
131-3701-345	BERYLLIUM COPPER NICKEL PL .0001 MIN OVER COPPER PL .00005 MIN	BRASS NICKEL PL .0001 MIN OVER COPPER PL .00005 MIN	BRASS GOLD PL .00003 MIN OVER NICKEL PL .00005 MIN OVER COPPER PL .00005 MIN	TEFLON	TEFLON	PHOSPHOR BRONZE NICKEL PL .0001 MIN OVER COPPER PL .00005 MIN	BRASS NICKEL PL .0001 MIN OVER COPPER PL .00005 MIN
131-3701-346	BRASS NICKEL PL .0001 MIN OVER COPPER PL .00005 MIN	BRASS NICKEL PL .0001 MIN OVER COPPER PL .00005 MIN	BRASS GOLD PL .00003 MIN OVER NICKEL PL .00005 MIN OVER COPPER PL .00005 MIN	TEFLON	TEFLON	PHOSPHOR BRONZE NICKEL PL .0001 MIN OVER COPPER PL .00005 MIN	BRASS NICKEL PL .0001 MIN OVER COPPER PL .00005 MIN
131-3701-347	BRASS GOLD PL .00001 MIN OVER NICKEL PL .00005 MIN OVER COPPER PL .00005 MIN	BRASS GOLD PL .00001 MIN OVER NICKEL PL .00005 MIN OVER COPPER PL .00005 MIN	BRASS GOLD PL .00003 MIN OVER NICKEL PL .00005 MIN OVER COPPER PL .00005 MIN	TEFLON	TEFLON	PHOSPHOR BRONZE GOLD PL .00001 MIN OVER NICKEL PL .00005 MIN OVER COPPER PL .00005 MIN	BRASS GOLD PL .00001 MIN OVER NICKEL PL .00005 MIN OVER COPPER PL .00005 MIN

DRAWING NO. C - 131-3701-341/350	
0 REVISIONS	
CHANGED: REVISED AND REDRAWN ON CAD. WAS "D" SIZE DATED 4-3-87. CHANGED: .100--.015 WAS .100--.005 ECO 40318	
04	04-03-91 R H B 4-12-91 ECO 40318
ADDED: P/N 131-3701-344	
5	8-29-92 R H B 9-22-92 ECO 41139
CHANGED: RF HIGH POT 4 AND 7 MHZ WAS 5 MHZ	
6	8-29-92 R H B 9-22-92 ECO 41189
ADDED: P/N 131-3701-345	
6a	5-15-95 R H B 5-17-95 ECN 43432
DELETED: WASHER & NUT FROM-345	
6b	9-19-95 R H B 9-21-95 ECN 43715
ADDED: WASHER AND NUT TO -345	
6c	2-26-96 R H B 3-22-96 ECN 43962
ADDED: P/N 131-3701-341/350	
***** * REVISION NUMBER FOLLOWED BY AN ALPHA * * CHARACTER INDICATED DRAWING CHANGE * * ACTION OR PART NUMBER ADDITION ONLY * *****	
6d	3-27-97 R H B ECN 44623

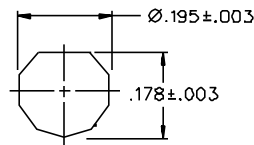
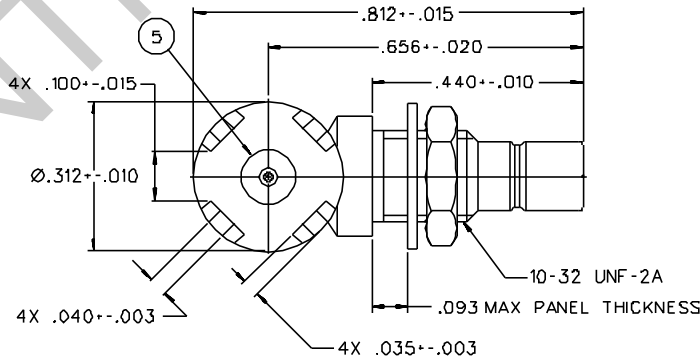
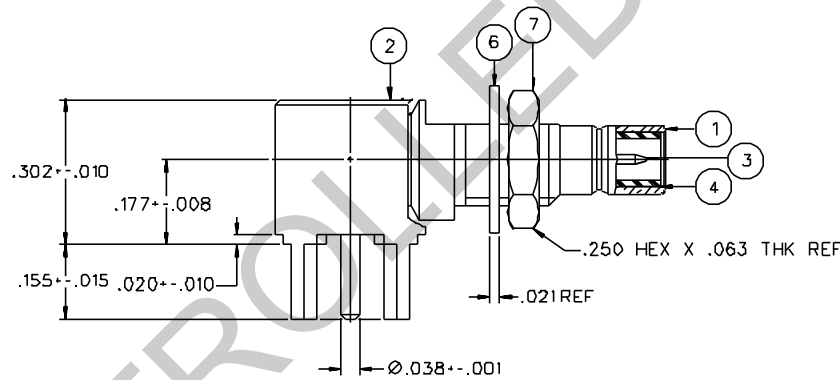
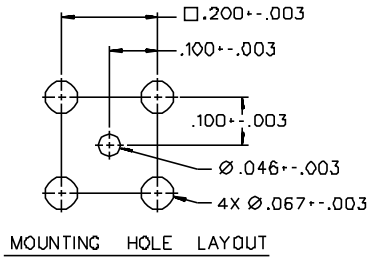

NOTES:

1. SPECIFICATIONS:

IMPEDANCE: 50 OHMS
 FREQUENCY RANGE: 0-4 GHz
 VSWR: NOT APPLICABLE
 WORKING VOLTAGE: 335 VRMS MAX AT SEA LEVEL
 DIELECTRIC WITHSTANDING VOLTAGE: 1000 VRMS MIN AT SEA LEVEL
 INSULATION RESISTANCE: 1000 MEGOHM MIN
 CONTACT RESISTANCE:

CENTER CONTACT - INITIAL 6 MILLIOHM MAX, AFTER ENVIRONMENTAL 8 MILLIOHM MAX
 OUTER CONDUCTOR - INITIAL 1 MILLIOHM MAX, AFTER ENVIRONMENTAL 1.5 MILLIOHM MAX

BRAID TO BODY - NOT APPLICABLE
 CORONA LEVEL: NOT APPLICABLE
 INSERTION LOSS: NOT APPLICABLE
 RF LEAKAGE: NOT APPLICABLE
 RF HIGH POTENTIAL WITHSTANDING VOLTAGE: 600 VRMS AT 4 AND 7 MHZ

MECHANICAL:

ENGAGE/DISENGAGE FORCE: INITIAL 14 LBS MAX, AFTER DURABILITY 14 LBS MAX ENGAGEMENT, 2 LBS MIN DISENGAGEMENT
 MATING TORQUE: NOT APPLICABLE
 COUPLING PROOF TORQUE: NOT APPLICABLE
 COUPLING NUT RETENSION: NOT APPLICABLE
 CONTACT RETENSION: 4 LBS MIN AXIAL FORCE
 CABLE ACCEPTABILITY: NOT APPLICABLE
 CABLE HEX CRIMP SIZE: NOT APPLICABLE
 CABLE RETENTION: NOT APPLICABLE
 DURABILITY: 500 CYCLES MIN

ENVIRONMENTAL:

(MEETS OR EXCEEDS THE APPLICABLE PARAGRAPH OF MIL-C-39012)
 THERMAL SHOCK: MIL-STD-202, METHOD 107, CONDITION B
 OPERATING TEMPERATURE: -65 DEG C TO 165 DEG C
 CORROSION: MIL-STD-202, METHOD 101, CONDITION B
 SHOCK: MIL-STD-202, METHOD 213, CONDITION B
 VIBRATION: MIL-STD-202, METHOD 204, CONDITION B

THIS DRAWING TO BE INTERPRETED PER ANSI Y 14.5M - 1982

"µSTATION"

COMPANY CONFIDENTIAL

TOLERANCE UNLESS OTHERWISE SPECIFIED	DRAWN BY BECKER	DATE 4-2-91	JOHNSON Cinch Connectivity Solutions 299 Johnson Ave. Ste. 100 Waseca, MN 56093 1-800-247-8256	
DECIMALS .XX	CHECKED BY	DATE	TITLE JACK ASSEMBLY, RA PC MOUNT BULKHEAD SMB	
.XXX±.003	APPROVED BY	DATE	CODE NO.	DRAWING NO. C - 131-3701-341/350
MATL	APPROVED BY RJB	DATE 4-10-91	SCALE	SHEET 2 OF 2
FINISH	RELEASE DATE	DATE 4-12-91 (4-3-87)	U/M INCH	