



Chipsmall Limited consists of a professional team with an average of over 10 year of expertise in the distribution of electronic components. Based in Hongkong, we have already established firm and mutual-benefit business relationships with customers from,Europe,America and south Asia,supplying obsolete and hard-to-find components to meet their specific needs.

With the principle of “Quality Parts,Customers Priority,Honest Operation,and Considerate Service”,our business mainly focus on the distribution of electronic components. Line cards we deal with include Microchip,ALPS,ROHM,Xilinx,Pulse,ON,Everlight and Freescale. Main products comprise IC,Modules,Potentiometer,IC Socket,Relay,Connector.Our parts cover such applications as commercial,industrial, and automotives areas.

We are looking forward to setting up business relationship with you and hope to provide you with the best service and solution. Let us make a better world for our industry!



Contact us

Tel: +86-755-8981 8866 Fax: +86-755-8427 6832

Email & Skype: info@chipsmall.com Web: www.chipsmall.com

Address: A1208, Overseas Decoration Building, #122 Zhenhua RD., Futian, Shenzhen, China



used for: D-SUB COMBINATION

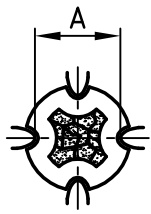

(c)

| Selector settings | Crimp height A |
|-------------------|----------------|
| 7 for AWG 20 | 0.87 - 0.98 |
| 6 for AWG 22 | 0.77 - 0.88 |
| 5 for AWG 24 | 0.67 - 0.78 |

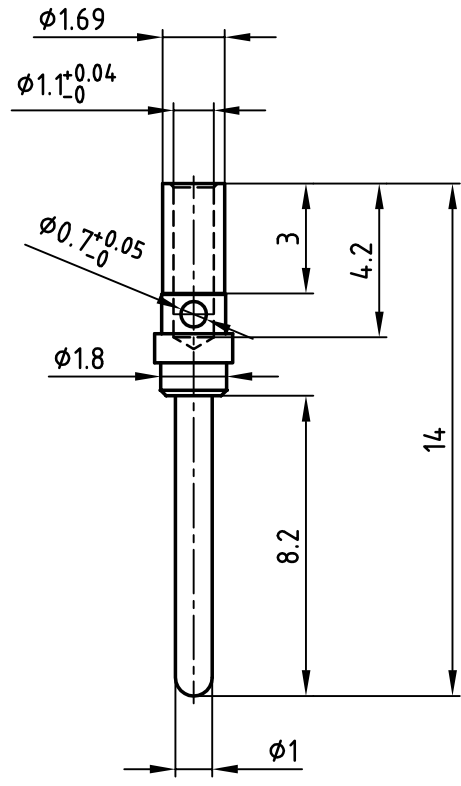

| Plating | Part-NO. |
|---|-------------------|
| min. 8µin HARD GOLD OVER min. 50µin NICKEL | 131A15019X |
| min. 20µin HARD GOLD OVER min. 50µin NICKEL | 131B15019X |
| min. 30µin HARD GOLD OVER min. 50µin NICKEL | 131C15019X |
| min. 50µin HARD GOLD OVER min. 50µin NICKEL | 131J15019X |

Directive 2002/95/EC
"RoHS"
Compliant

(b) STRIPPING DIMENSION

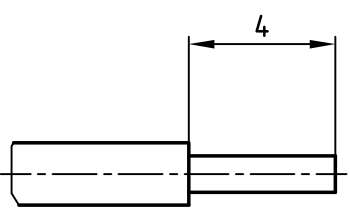

NOTES:

1. MATERIAL: COPPER ALLOY
2. PLATING: SEE TABLE
- (b) 3. CRIMPING: USE CRIMP TOOL 360X10329X WITH TOOL INSERT 360X20039X
SELECTOR SETTINGS: 7 FOR AWG 20
6 FOR AWG 22
5 FOR AWG 24

THIS DRAWING MAY NOT BE COPIED OR REPRODUCED IN ANY WAY, AND MAY NOT BE PASSED ON TO A THIRD PARTY WITHOUT WRITTEN PERMISSION. OWNERSHIP AND COPYRIGHT OF CONEC GmbH DO NOT ALTER CAD DRAWING BY HAND

| | | | | tolerance | | | | scale: 5:1 | |
|-------|-------------|------------|--------|---------------------|--------|--|-------|--|--|
| | | | | material: SEE NOTES | | title: SIGNAL CRIMP CONTACT MALE CONTACT Wire Size 20-24 | | | |
| | | | | 2002 | date | name | | dwg no: AutoCAD 2000 16K1A470A part no: SEE TABLE | |
| | | | | drawn | 30.01. | Parei | | | |
| | | | | appd. | 30.01. | E. Mickenbecker | | | |
| | | | | norm | | | | | |
| 1 x d | Ä 3703 | 02.08.2010 | K.H. | d-old | | | DIN-A | | |
| 1 x c | Ä 2197 | 01.04.2005 | Lehmen | | | | | 4 | |
| 2 x b | Ä 2177 | 02.03.2005 | Lehmen | | | | | sh: 1/1 | |
| rev. | description | date | name | | | | | | |

