



Chipsmall Limited consists of a professional team with an average of over 10 year of expertise in the distribution of electronic components. Based in Hongkong, we have already established firm and mutual-benefit business relationships with customers from,Europe,America and south Asia,supplying obsolete and hard-to-find components to meet their specific needs.

With the principle of “Quality Parts,Customers Priority,Honest Operation,and Considerate Service”,our business mainly focus on the distribution of electronic components. Line cards we deal with include Microchip,ALPS,ROHM,Xilinx,Pulse,ON,Everlight and Freescale. Main products comprise IC,Modules,Potentiometer,IC Socket,Relay,Connector.Our parts cover such applications as commercial,industrial, and automotives areas.

We are looking forward to setting up business relationship with you and hope to provide you with the best service and solution. Let us make a better world for our industry!



Contact us

Tel: +86-755-8981 8866 Fax: +86-755-8427 6832

Email & Skype: info@chipsmall.com Web: www.chipsmall.com

Address: A1208, Overseas Decoration Building, #122 Zhenhua RD., Futian, Shenzhen, China



| REVISION | | | |
|----------|-------------|------|----------|
| REV. | DESCRIPTION | DATE | APPROVED |
| | | | |
| | | | |

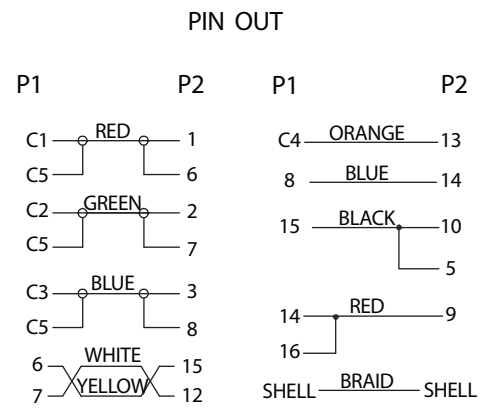
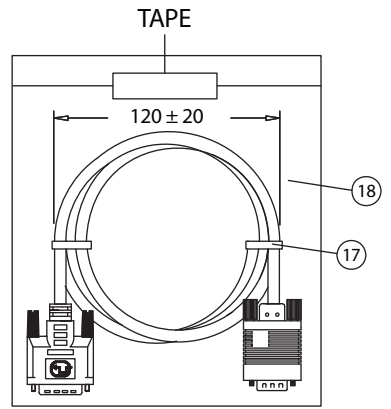
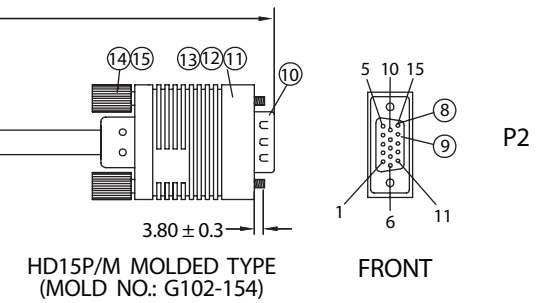
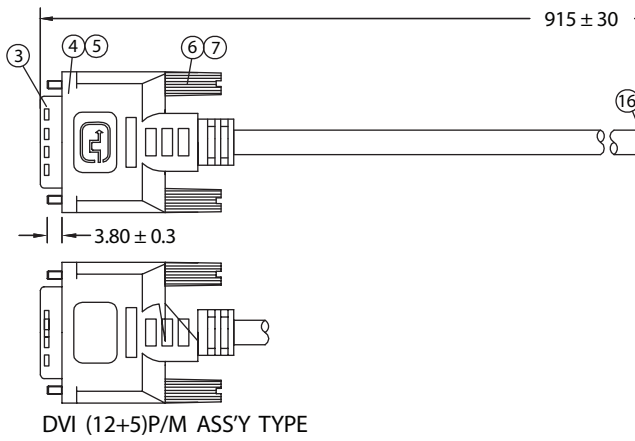
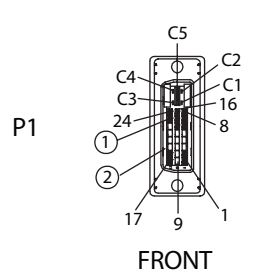

| No. | PARTS NAME | SPECIFICATION STANDARD | QTY |
|-----|---------------------------|---------------------------------|-----|
| ① | DVI (12+5)P/M - CONTACT | BRONZE/GOLD FLASH SOLDER TYPE | 17 |
| ② | DVI (12+5)P/M - INSULATOR | PBT/BLACK UL 94V-0 | 1 |
| ③ | DVI (12+5)P/M - SHELL | STEEL NICKEL PLATED | 1 |
| ④ | DVI (12+5)P/M - CAN | STEEL TIN PLATED | 1 |
| ⑤ | DVI (12+5)P/M - COVER | 45P PVC/COLOR: BEIGE | 1 |
| ⑥ | THUMB SCREW | #4-40 2.8x45, NICKEL PLATED | 2 |
| ⑦ | SCREW MOLD | 35P PVC/COLOR: BLACK | 2 |
| ⑧ | HD15P/M - CONTACT | BRASS GOLD FLASH SOLDER TYPE | 15 |
| ⑨ | HD15P/M - INSULATOR | PBT/BLACK UL 94V-0 | 1 |
| ⑩ | HD15P/M - SHELL | STEEL NICKEL PLATED | 1 |
| ⑪ | HD15P/M - INNER MOLD | PE NATURAL | 1 |
| ⑫ | HD15P/M - COPPER FOIL | WIDTH: 28mm | 1 |
| ⑬ | HD15P/M - OUTER MOLD | 45P PVC/COLOR: BEIGE | 1 |
| ⑭ | HD15P/M - THUMB SCREW | UNC #4-40 Ø4xL50, NICKEL PLATED | 2 |
| ⑮ | HD15P/M - SCREW MOLD | 35P PVC/COLOR: BLACK | 2 |
| ⑯ | CABLE DVI 12+5 UL20276 | L03010ABK01A | 1 |
| ⑰ | MINI TIE | PE/BLACK | 2 |
| ⑱ | POLYBAG | PE/0.8x160x200mm | 1 |

NOTES:

- CABLE: UL20276
(28AWGxSP+FOIL)x3C+28AWGx4C+28AWGx1P+MYLAR+FOIL+BD
OUTER JACKET: BEIGE, OD: 6.5 ± 0.2mm
PRINTING: "E166307 AWM 20276 28AWG 80°C 30V WW-1
LOW VOLTAGE COMPUTER CABLE"
- CONNECTORS: DVI (12+5)P/M-HD15P/M
- HOOD: ASSY TYPE & MOLDED TYPE
- ELECTRICAL TEST:
 - <1>.100% OPEN SHORT & MISS WIRE TEST
 - <2>.INSULATION RESISTANCE: DC400V 10M ohm MIN.
 - <3>.CONDUCTOR RESISTANCE: 3 ohm MAX.
- PACKING: 1PC/POLYBAG

Qualtek Electronics Corp.
WCI DIVISION

Part Number: **1321002-03** RoHS Compliant

Description: **DVI (12+5)P/M - HD15P/M**

| Dim range (mm) | Tolerance +/- (mm) | Drawn / Date | Checked / Date | Approved / Date |
|----------------|--------------------|---------------------|----------------|-----------------|
| 0-1 | 0.15 | B.Grubb 01-24-07 | 01-24-07 | JJH / 01-24-07 |
| 1-6 | 0.20 | | | |
| 6-18 | 0.30 | | | |
| 18-50 | 0.50 | | | |
| 50-120 | 0.70 | | | |
| 120-250 | 0.90 | | | |
| 250-500 | 1.20 | | | |