



Chipsmall Limited consists of a professional team with an average of over 10 year of expertise in the distribution of electronic components. Based in Hongkong, we have already established firm and mutual-benefit business relationships with customers from,Europe,America and south Asia,supplying obsolete and hard-to-find components to meet their specific needs.

With the principle of “Quality Parts,Customers Priority,Honest Operation,and Considerate Service”,our business mainly focus on the distribution of electronic components. Line cards we deal with include Microchip,ALPS,ROHM,Xilinx,Pulse,ON,Everlight and Freescale. Main products comprise IC,Modules,Potentiometer,IC Socket,Relay,Connector.Our parts cover such applications as commercial,industrial, and automotives areas.

We are looking forward to setting up business relationship with you and hope to provide you with the best service and solution. Let us make a better world for our industry!



Contact us

Tel: +86-755-8981 8866 Fax: +86-755-8427 6832

Email & Skype: info@chipsmall.com Web: www.chipsmall.com

Address: A1208, Overseas Decoration Building, #122 Zhenhua RD., Futian, Shenzhen, China



REVISION			
REV.	DESCRIPTION	DATE	APPROVED

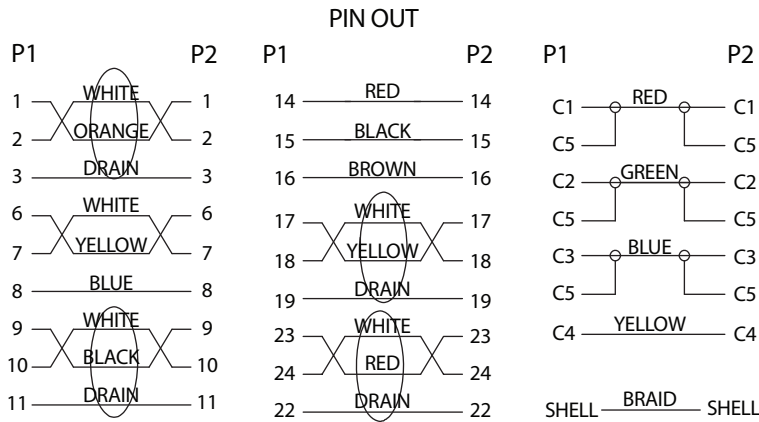
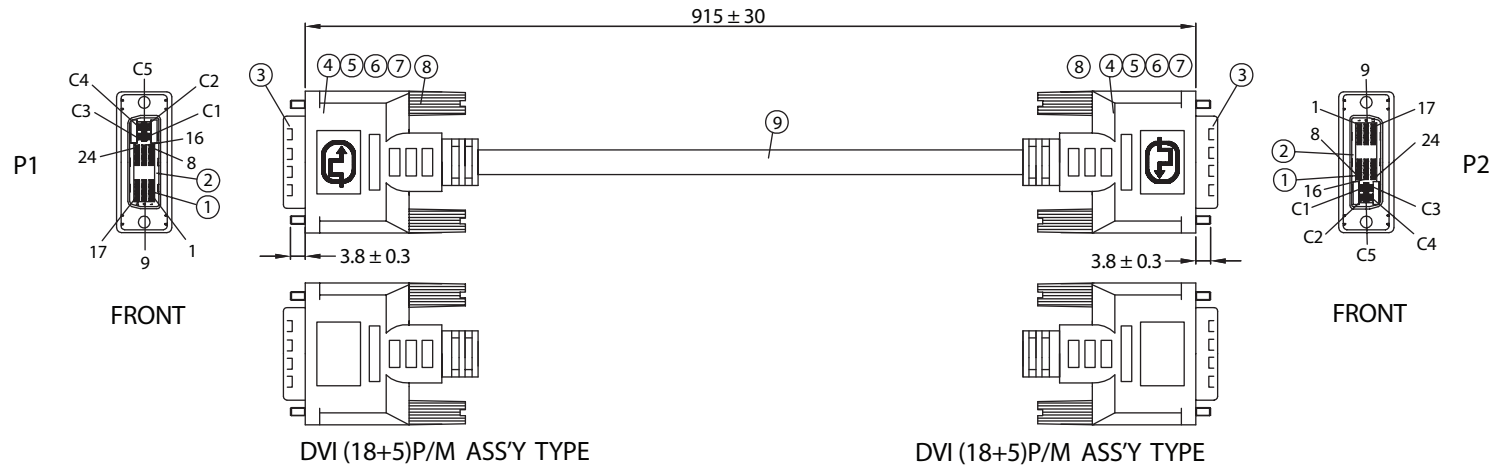
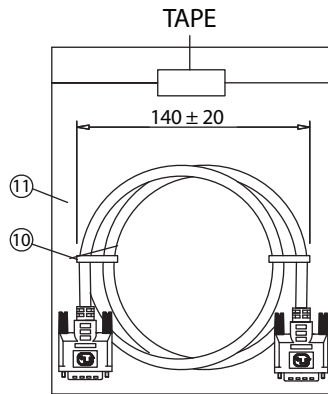

NOTES:

- CABLE:**
 (28AWGx1P+DW+FOIL)x4P+(28AWG+SP+FOIL)x3C+28AWGx5C+28AWGx1P+MYLAR+FOIL+BD
 OUTER JACKET: BEIGE, OD: 8.5 ± 0.3mm
 PRINTING: "E166307 AWM 20276 28AWG 80°C 30V VW-1
 LOW VOLTAGE COMPUTER CABLE"
- CONNECTORS:** DVI (18+5)P/M - DVI (18+5)P/M
- HOOD:** ASSY TYPE
- CABLE ELECTRICAL TEST:**
 - <1>.100% OPEN SHORT & MISS WIRE TEST
 - <2>.INSULATION RESISTANCE: DC400V 10M ohm MIN.
 - <3>.CONDUCTOR RESISTANCE: 3 ohm MAX.
- PACKING:** 1PC/POLYBAG

No.	PARTS NAME	SPECIFICATION STANDARD	QTY	REMARKS
①	DVI (18+5)P/M - CONTACT	BRONZE/GOLD PLATED SOLDER TYPE	46	MAIN SUPER or EQUIV
②	DVI (18+5)P/M - INSULATOR	THERMOPLASTIC/BLACK UL94V-0	2	
③	DVI (18+5)P/M - SHELL	STEEL NICKEL PLATED	2	
④	COPPER FOIL	WIDTH: 8mm	2	
⑤	CAN	STEEL TIN PLATED ID:9.0mm	2	
⑥	OUTER COVER	45P PVC/BEIGE, ID: 9.0mm	2	
⑦	THUMB SCREW	#4-40 2.8x45, NICKEL PLATED	4	
⑧	SCREW - MOLD	35P PVC/COLOR: BLACK	4	
⑨	CABLE DVI 18+5 UL20276	KL03008ABK01A	1	
⑩	MINI TIE	PE/BLACK	2	
⑪	POLYBAG	PE/0.08x180x220mm	1	

Dim range (mm)	Tolerance +/- (mm)	Qualtek Electronics Corp. WCI DIVISION		
		Part Number: 1321006-03		
0-1	0.15	Description: DVI(18+5)P/M - DVI(18+5)P/M		
1-6	0.20			
6-18	0.30			
18-50	0.50			
50-120	0.70	Drawn / Date	Checked / Date	Approved / Date
120-250	0.90	B.Grubb 01-11-07	01-11-07	JJH / 01-11-07
250-500	1.20			