



Chipsmall Limited consists of a professional team with an average of over 10 year of expertise in the distribution of electronic components. Based in Hongkong, we have already established firm and mutual-benefit business relationships with customers from,Europe,America and south Asia,supplying obsolete and hard-to-find components to meet their specific needs.

With the principle of “Quality Parts,Customers Priority,Honest Operation,and Considerate Service”,our business mainly focus on the distribution of electronic components. Line cards we deal with include Microchip,ALPS,ROHM,Xilinx,Pulse,ON,Everlight and Freescale. Main products comprise IC,Modules,Potentiometer,IC Socket,Relay,Connector.Our parts cover such applications as commercial,industrial, and automotives areas.

We are looking forward to setting up business relationship with you and hope to provide you with the best service and solution. Let us make a better world for our industry!



Contact us

Tel: +86-755-8981 8866 Fax: +86-755-8427 6832

Email & Skype: info@chipsmall.com Web: www.chipsmall.com

Address: A1208, Overseas Decoration Building, #122 Zhenhua RD., Futian, Shenzhen, China



LOC	DIST	REV	DATE	BY	CHK	APPD
FX	00					
B		REVISED PER ECO-10-010364	27SEP2010	DLD	CJS	
B1		REVISED PER ECO-11-005947	22MAR2011	DLD	CJS	

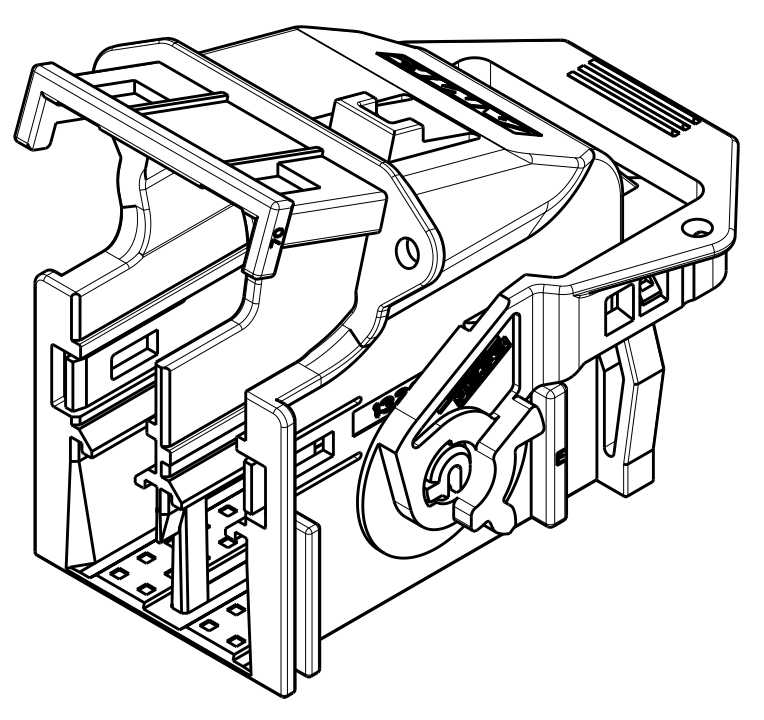

SCALE 2:1

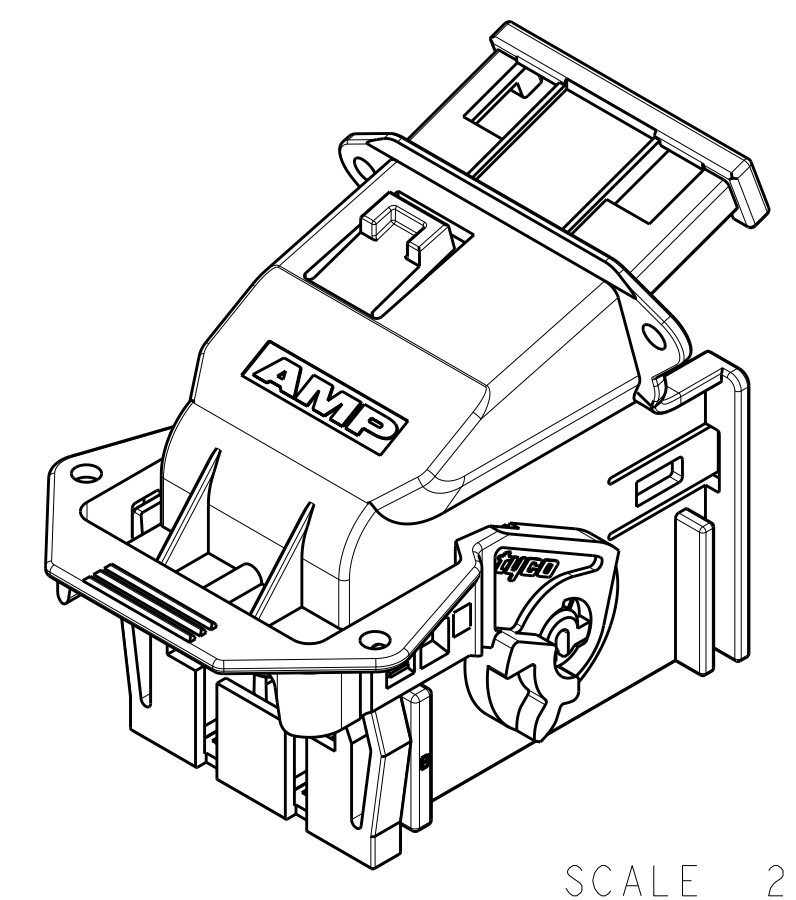
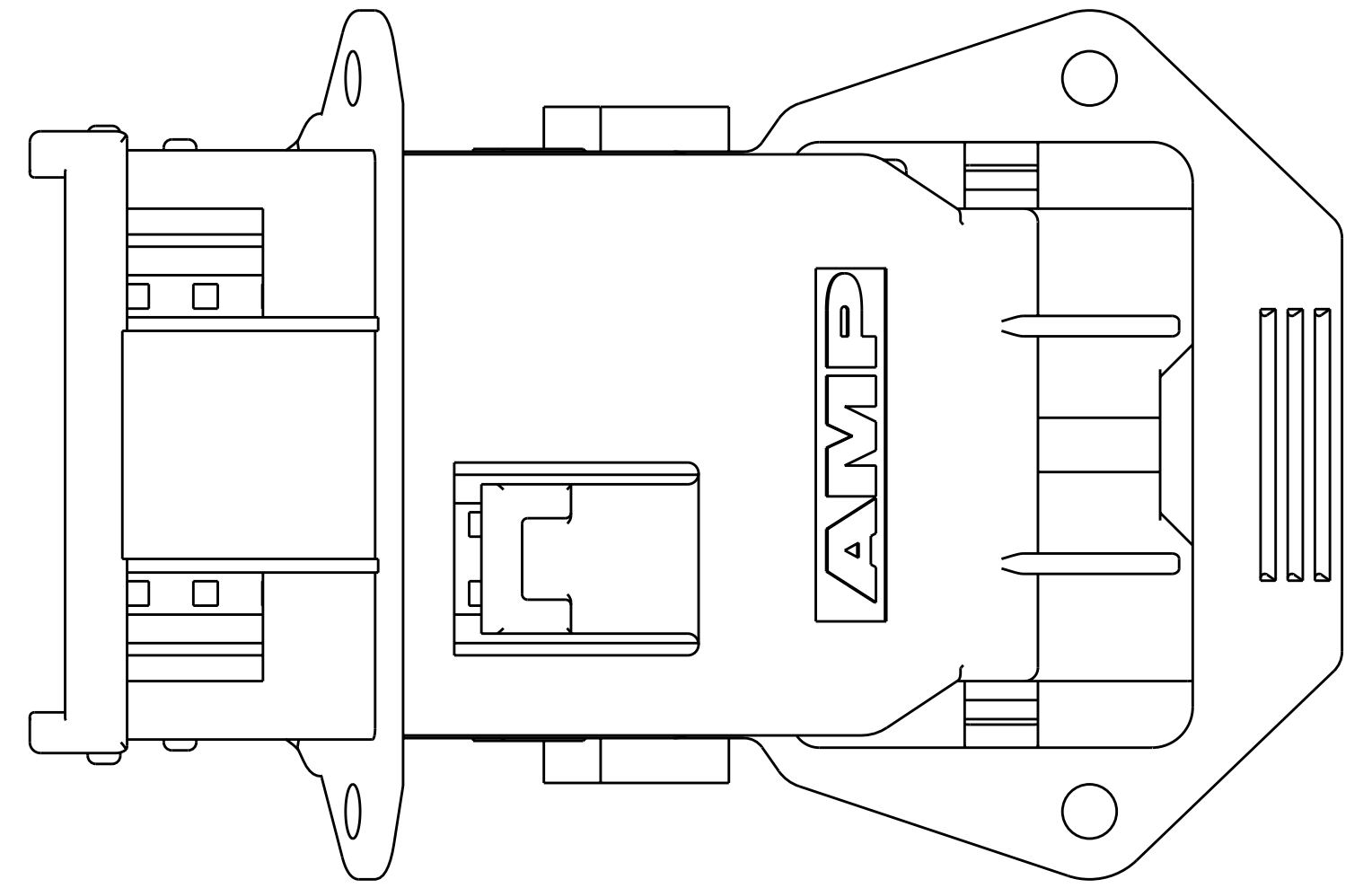

SCALE 2:1

- 1. MATERIAL: SHIELD - 35% GLASS REINFORCED NYLON. SEE TABLE BELOW FOR COLOR. LEVER - 35% GLASS REINFORCED NYLON. COLOR: DARK GREY.
- 2. ANTI-SCOOPING FEATURE OPTIONAL CONSTRUCTION.
- 3. REFERENCE: RECEPTACLE HOUSING, 1326042-1 & 1326042-2, USED WITH THIS ASSEMBLY.
- 4. REFERENCE: INTERFACE DETAIL PER DRAWING NO. AUAUTO1000-2962-0010 AND TE DRAWING NO. 1438985-GEN.
- 5. REFER TO INSTRUCTION SHEET 408-8662 FOR PRODUCT ASSEMBLY AND DISASSEMBLY PROCEDURES.
- 6. REFER TO USCAR-2 REV 3 APRIL 2001 FOR PRODUCT SPECIFICATIONS.

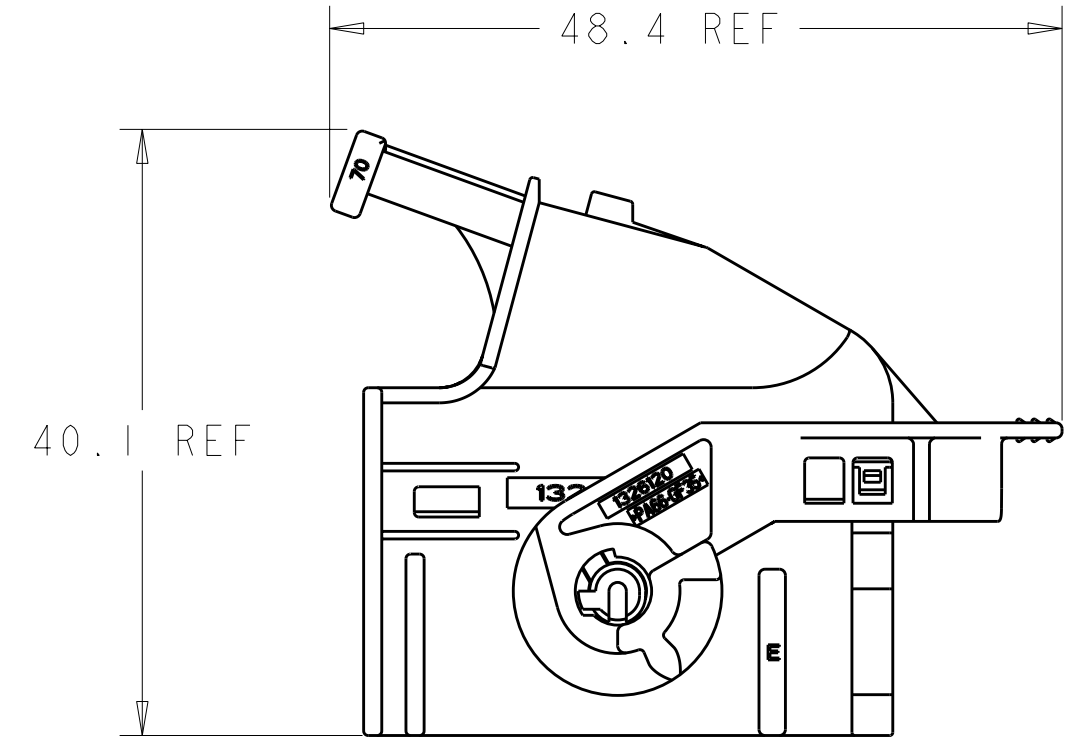
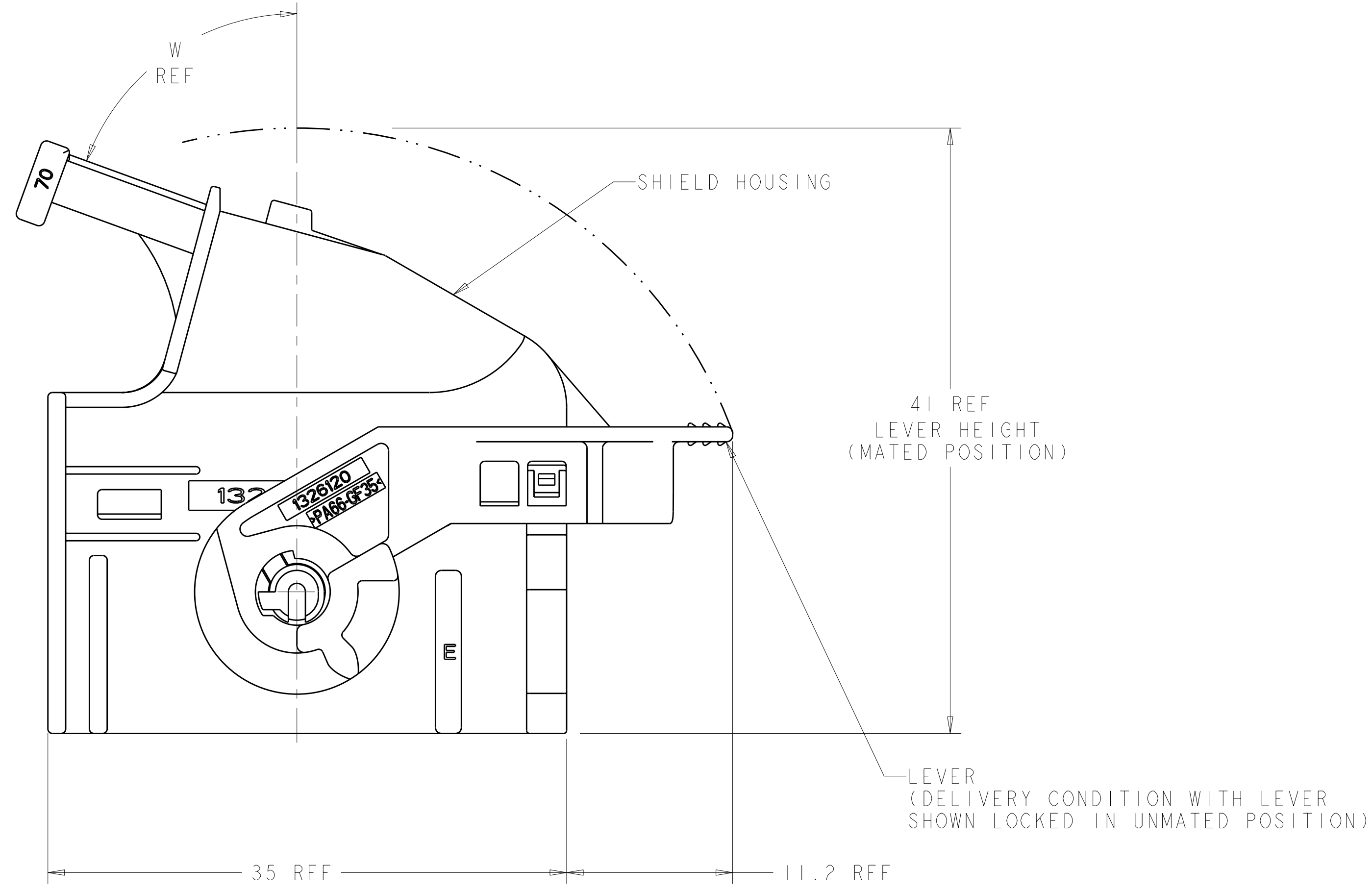
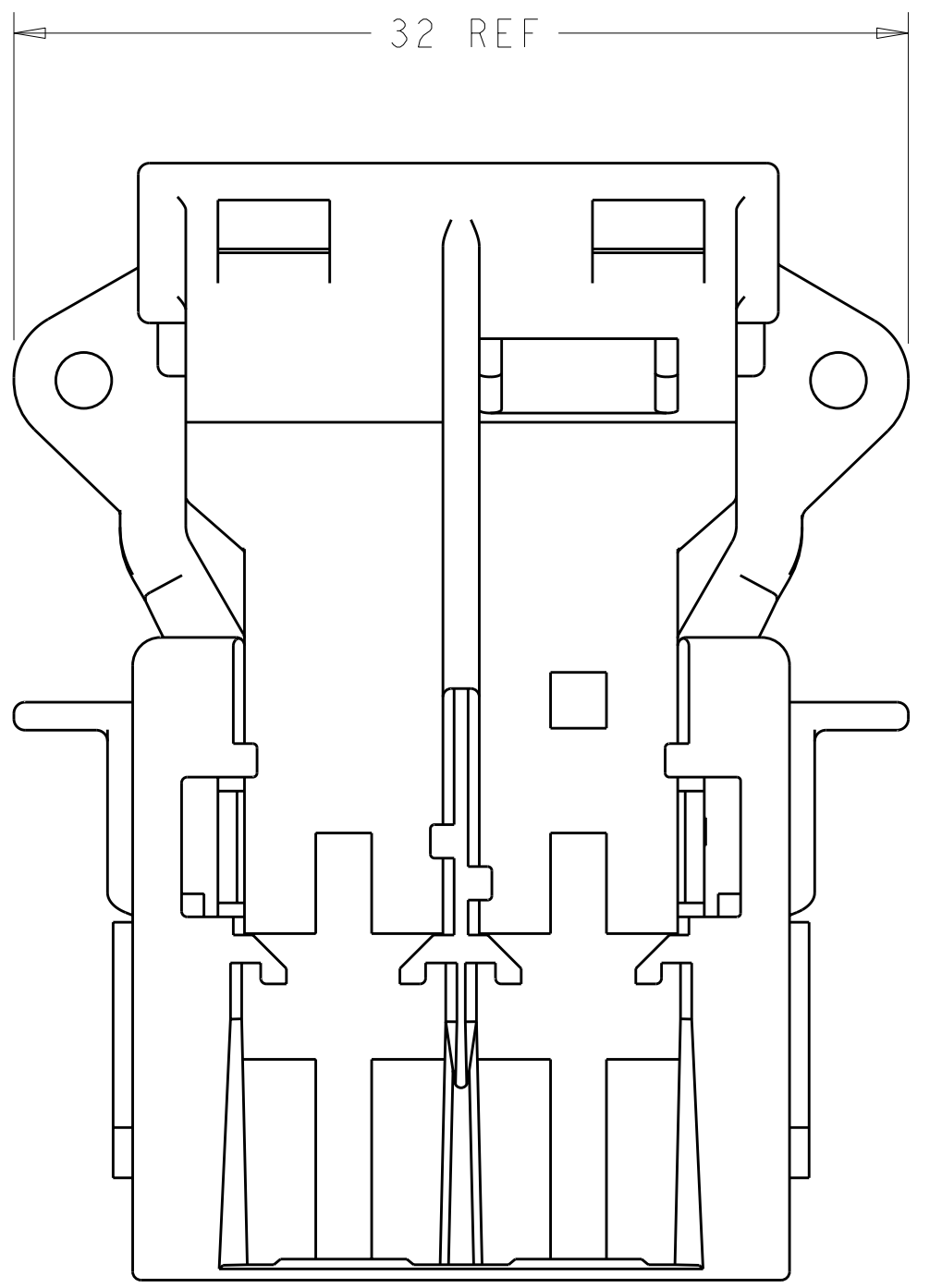

70° WIRE EXIT
SCALE 2:1

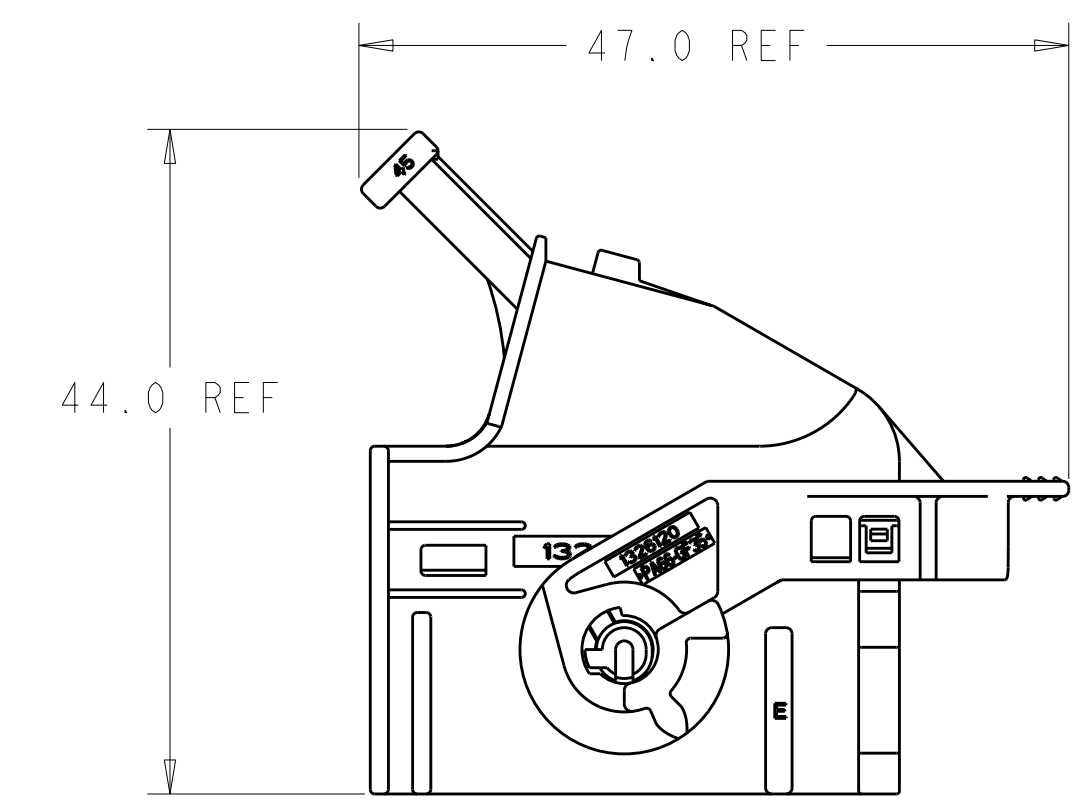

45° WIRE EXIT
SCALE 2:1

DIM W	COLOR	KEYING OPT.	PART NUMBER
45°	BLUE	B-F	1326122-6
45°	GRAY	B-E	1326122-5
45°	BLACK	A-E	1326122-4
70°	BLUE	B-F	1326122-3
70°	GRAY	B-E	1326122-2
70°	BLACK	A-E	1326122-1

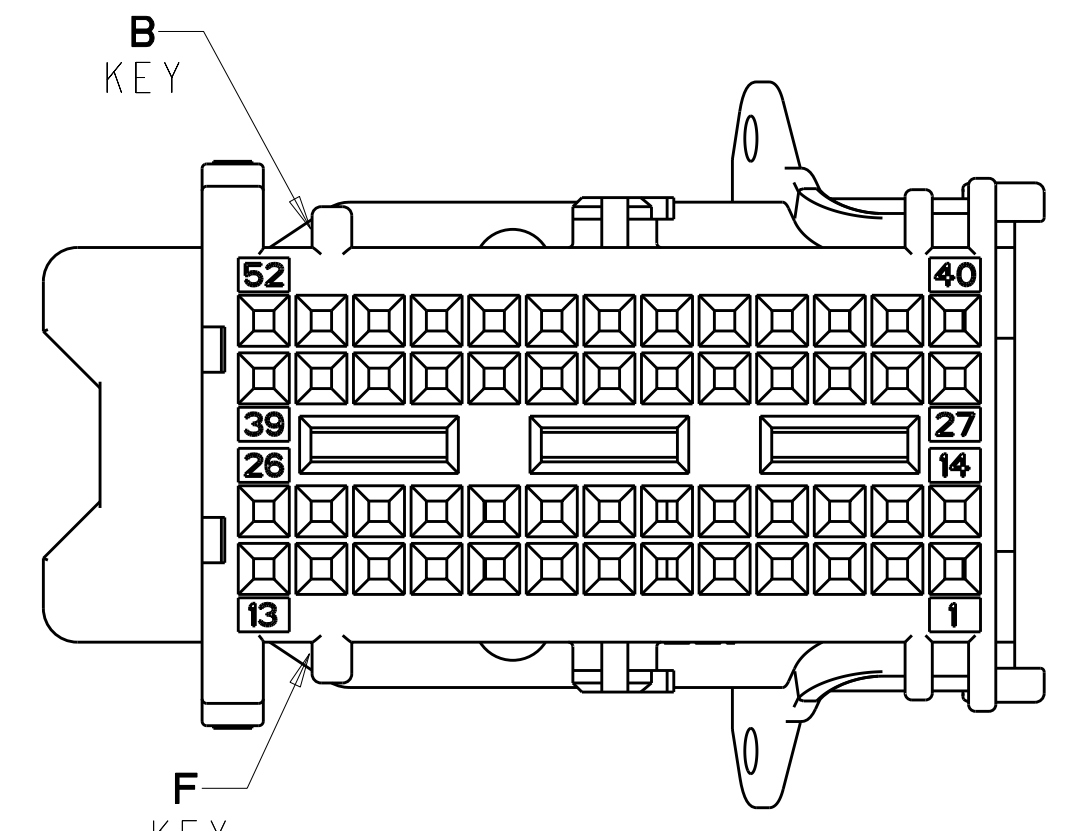

KEY B-F SHOWN FOR
ASSEMBLY 1326122-3
& 1326122-6

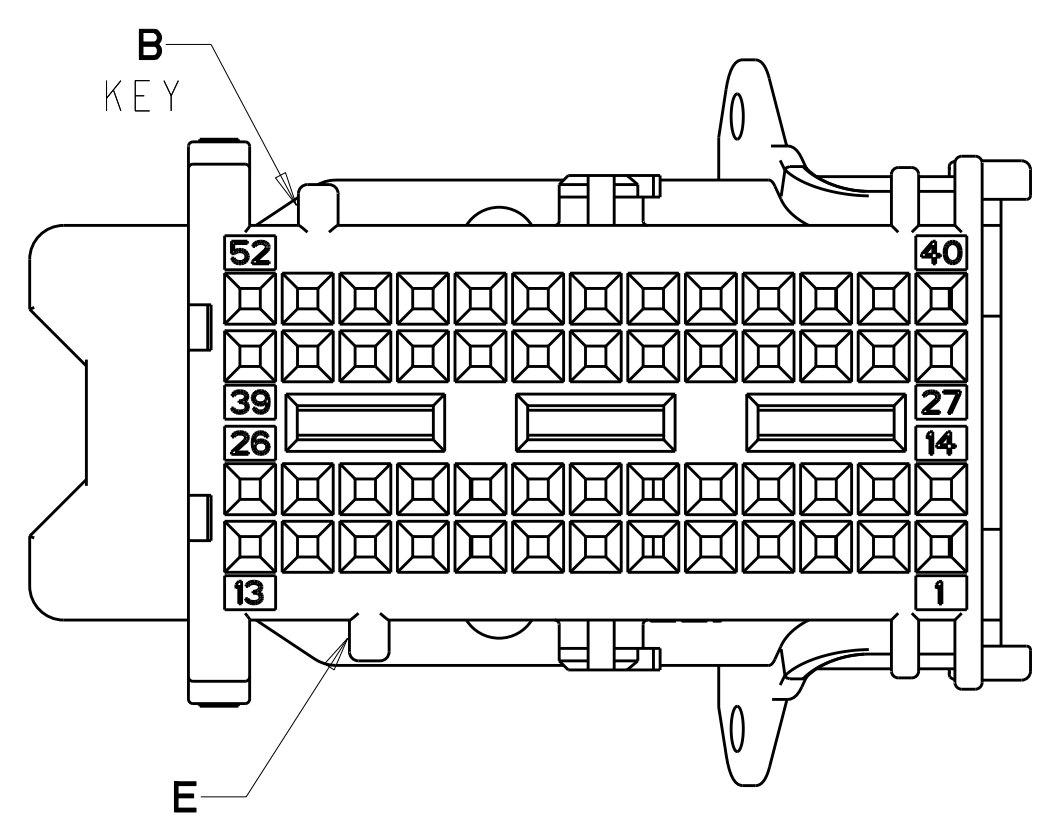

KEY B-E SHOWN FOR
ASSEMBLY 1326122-2
& 1326122-5

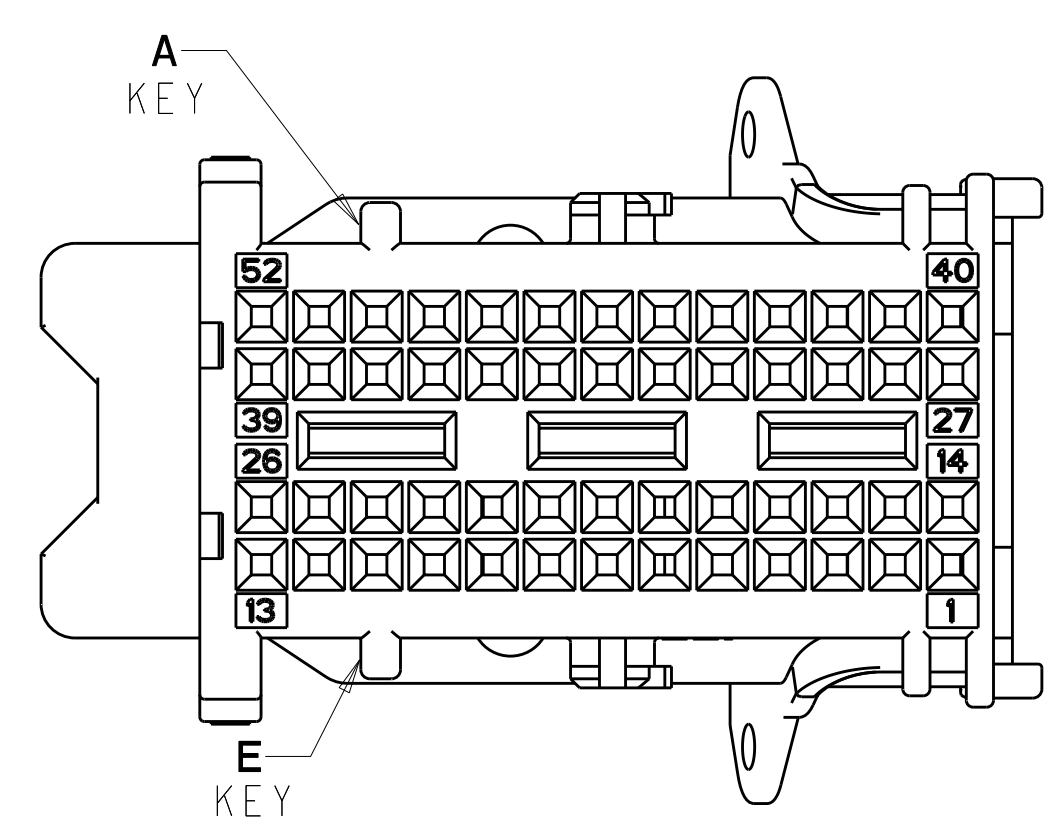

KEY A-E SHOWN FOR
ASSEMBLY 1326122-1
& 1326122-4

DIMENSIONS: mm 		TOLERANCES UNLESS OTHERWISE SPECIFIED: 9 PLC ± 1 PLC ±0.2 3 PLC ±0.05 4 PLC ± ANGLES ± FINISH		DWN T. WOOTEN 07JUL2000 CHK C. MARTIN 07JUL2000 APVD D. KLEIN 07JUL2000 PRODUCT SPEC APPLICATION SPEC WEIGHT CUSTOMER DRAWING		Tyco Electronics Harrisburg, PA 17105-3608 NAME SHIELD ASSEMBLY, 52 POSITION, LEVER ASSISTED CONNECTOR SIZE CAGE CODE DRAWING NO. RESTRICTED TO A11 00779 C=1326122 SCALE 4:1 SHEET 1 OF 2 REV B1	
-----------------------	--	---	--	---	--	---	--

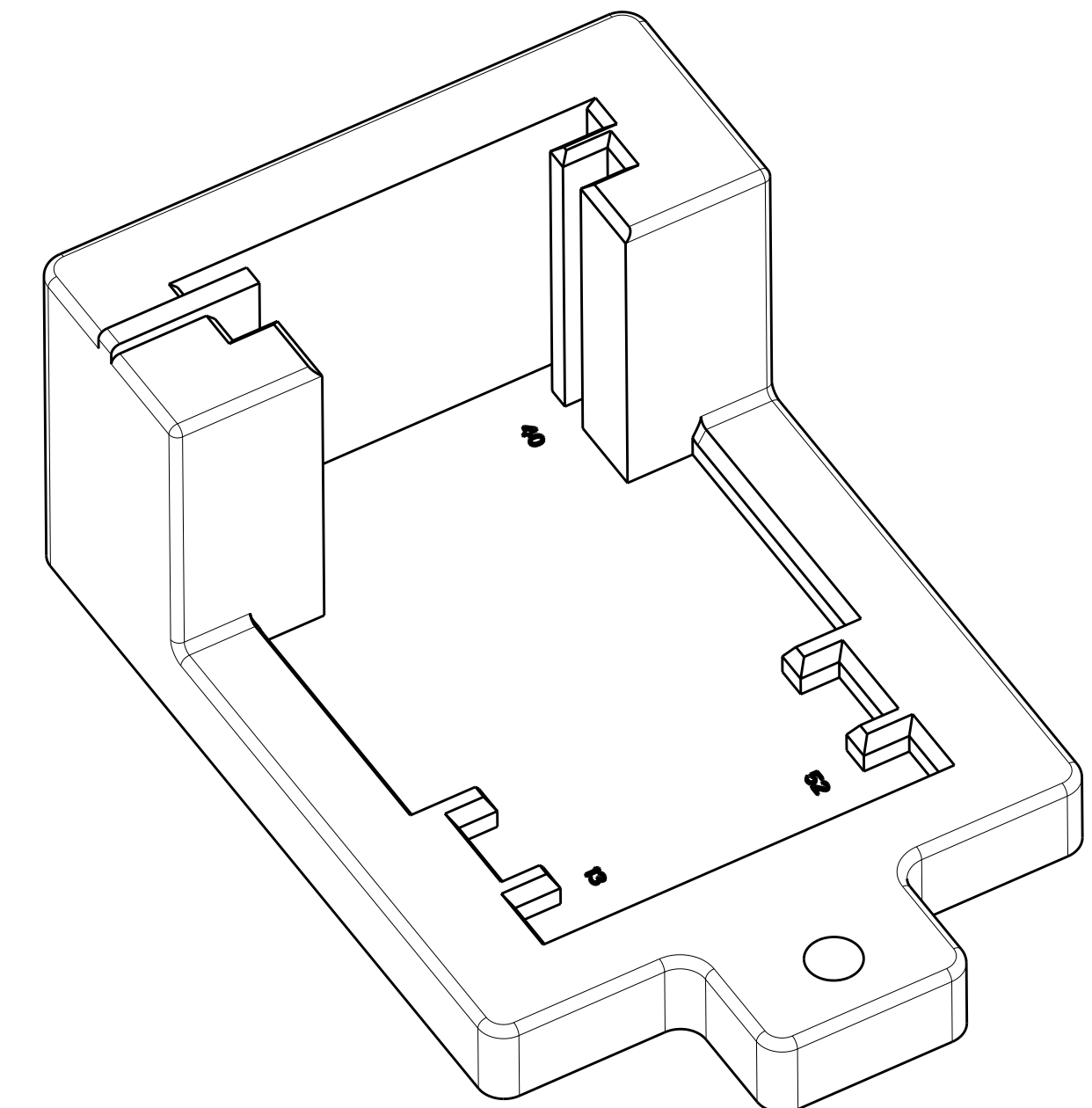
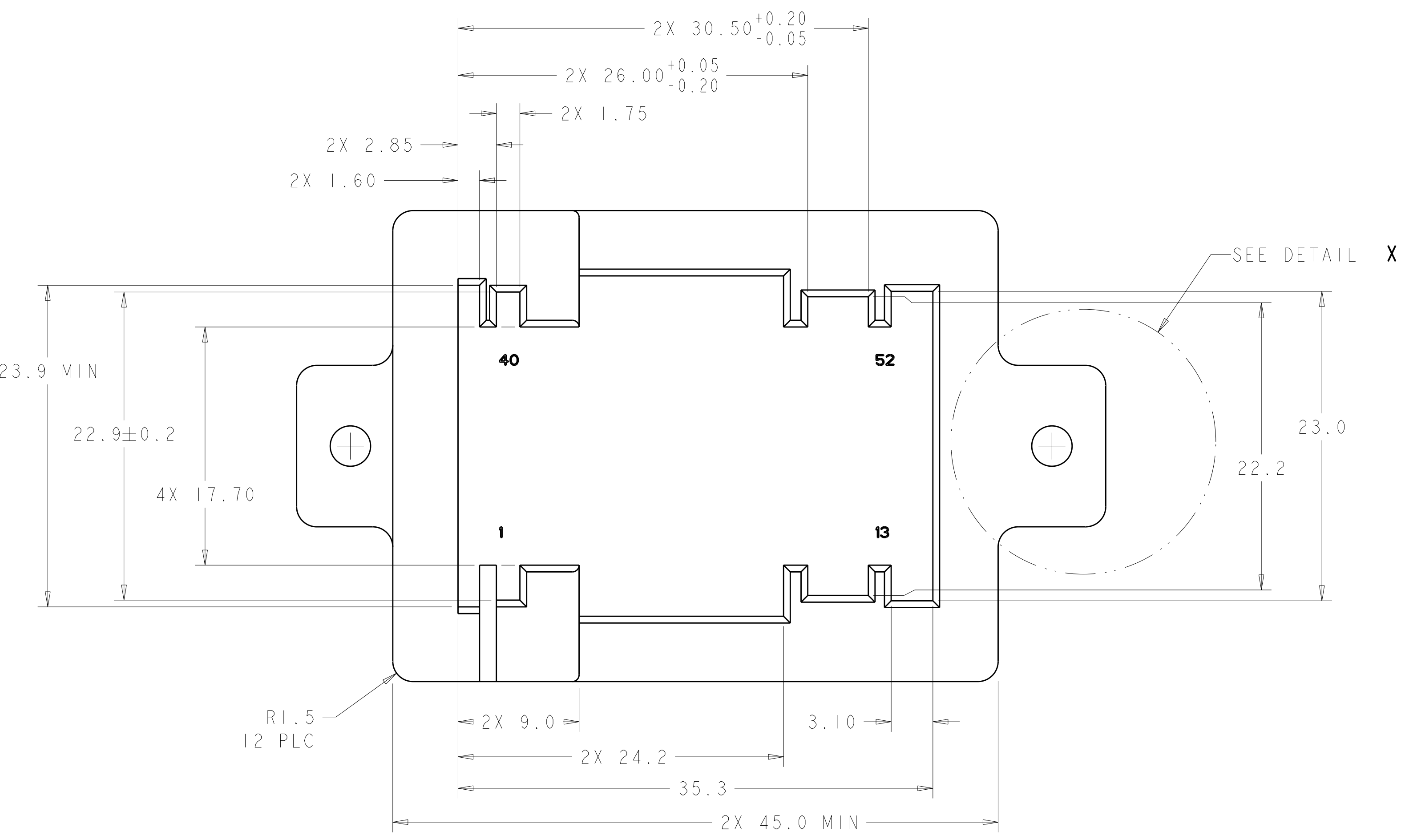

SCALE 3:1

LOC	DIST	REV	DESCRIPTION	DATE	OWN	APVD
FX	00		SEE SHEET 1			

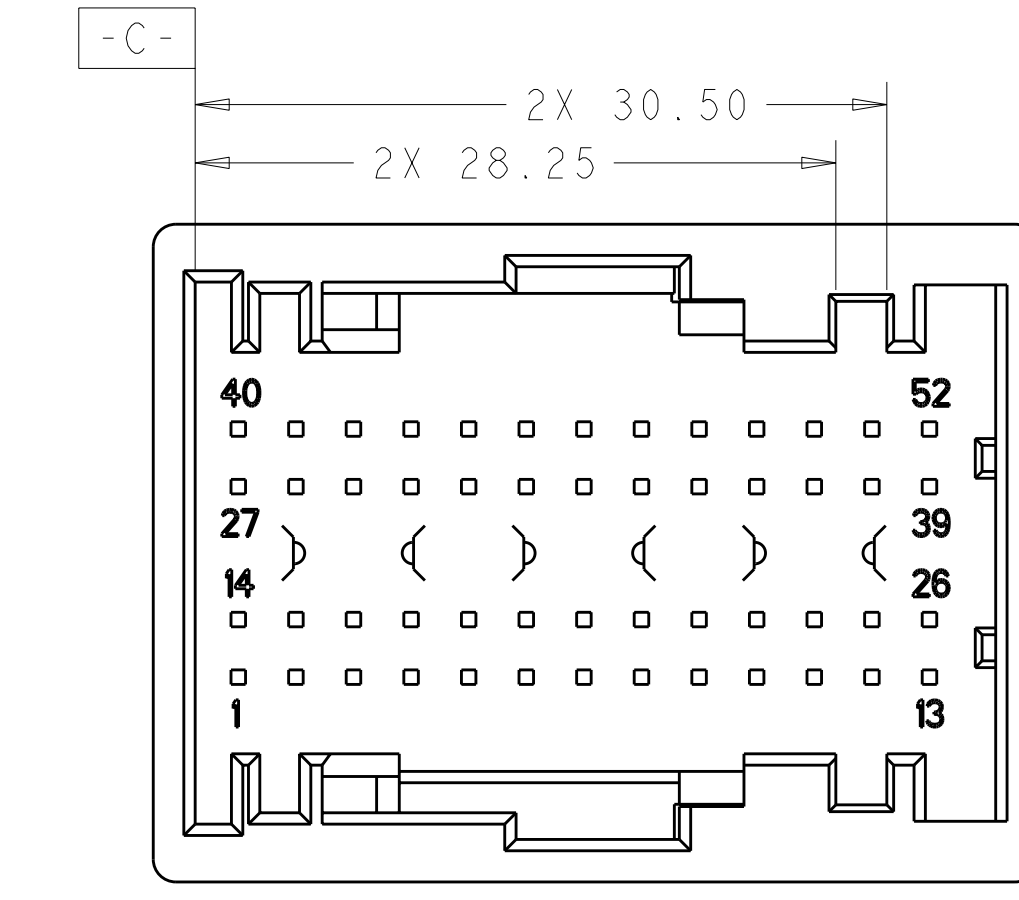
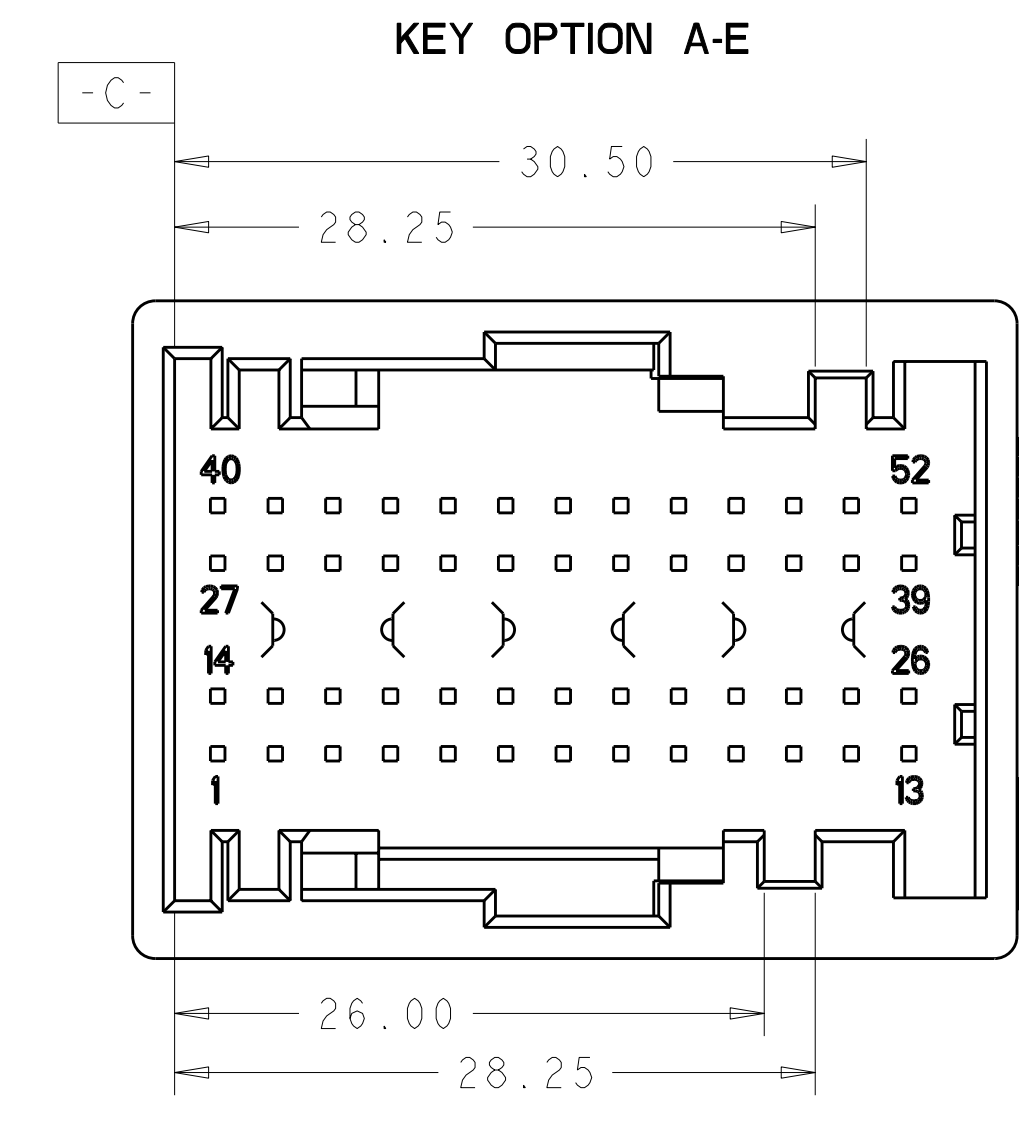
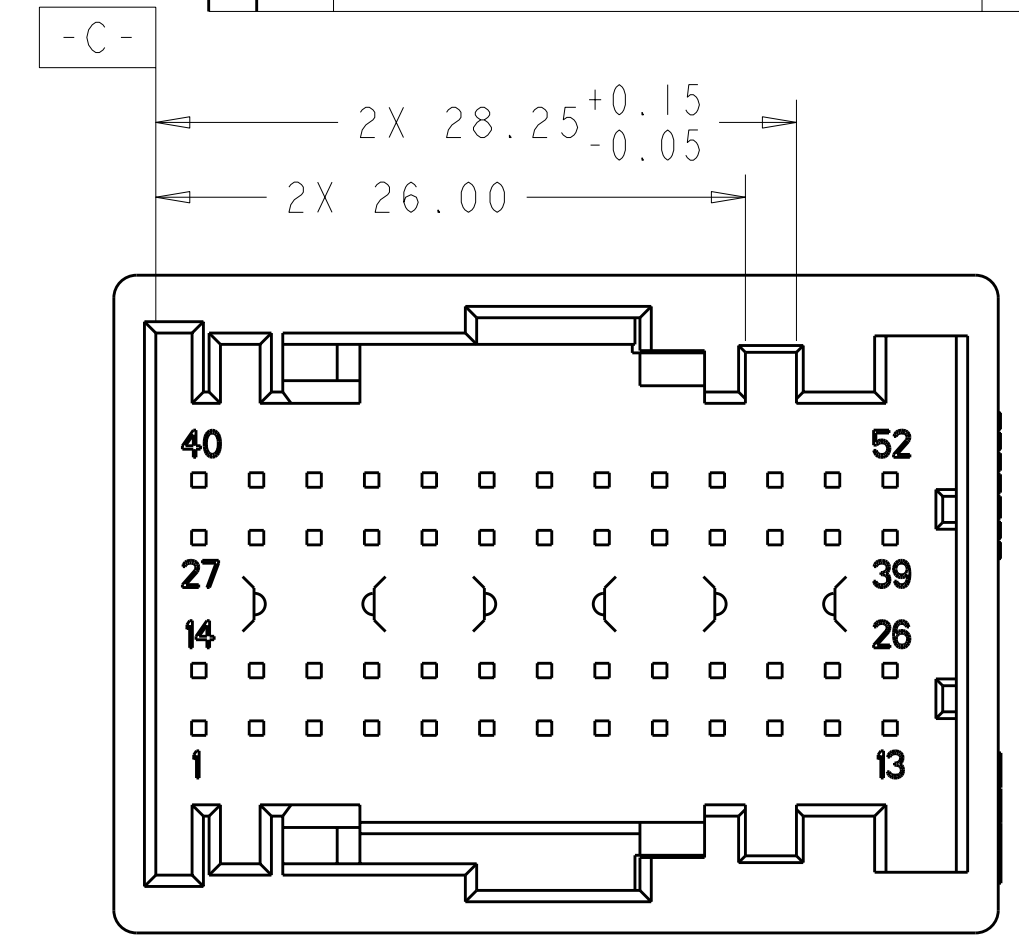

KEYING OPTIONS

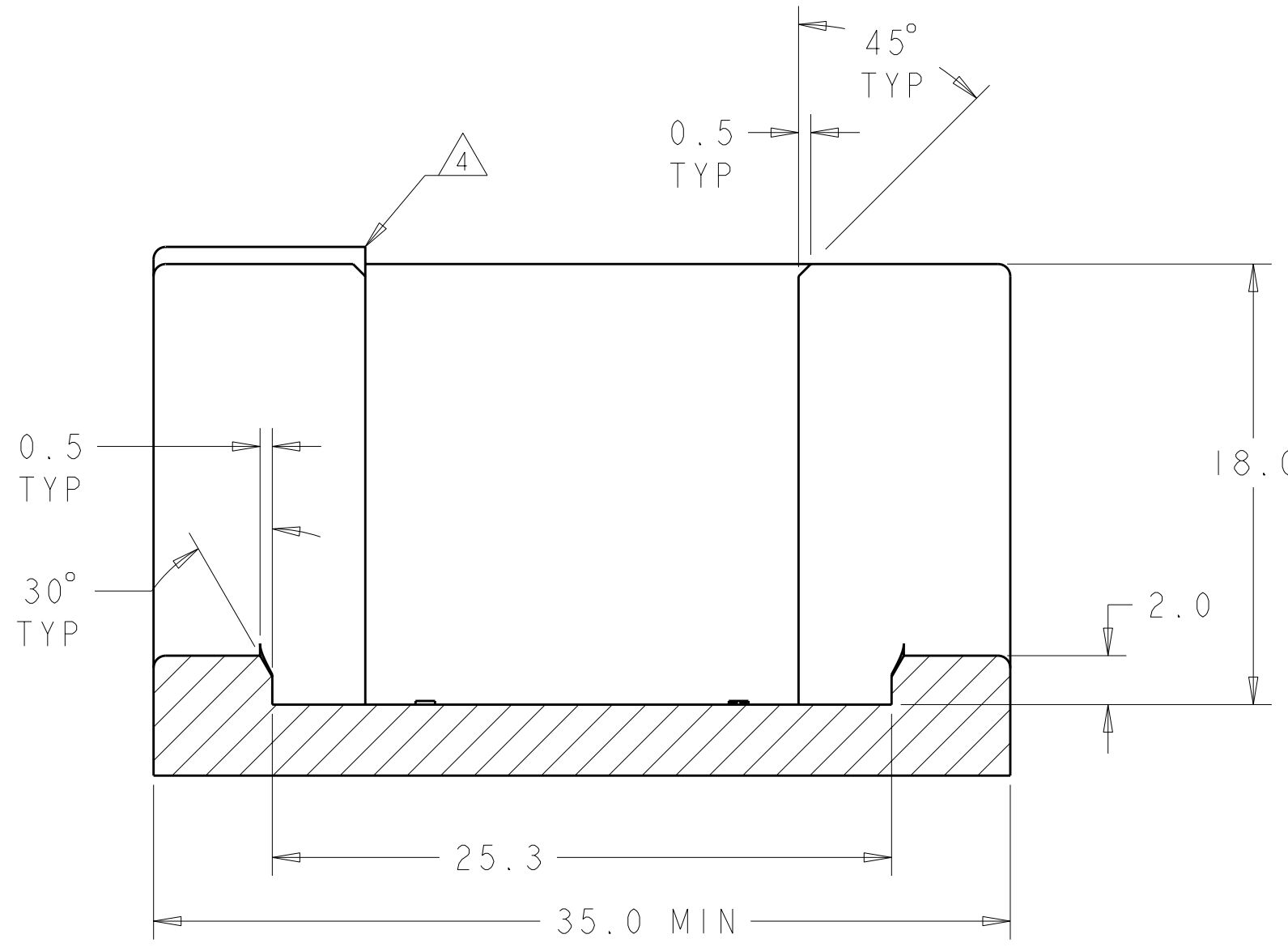
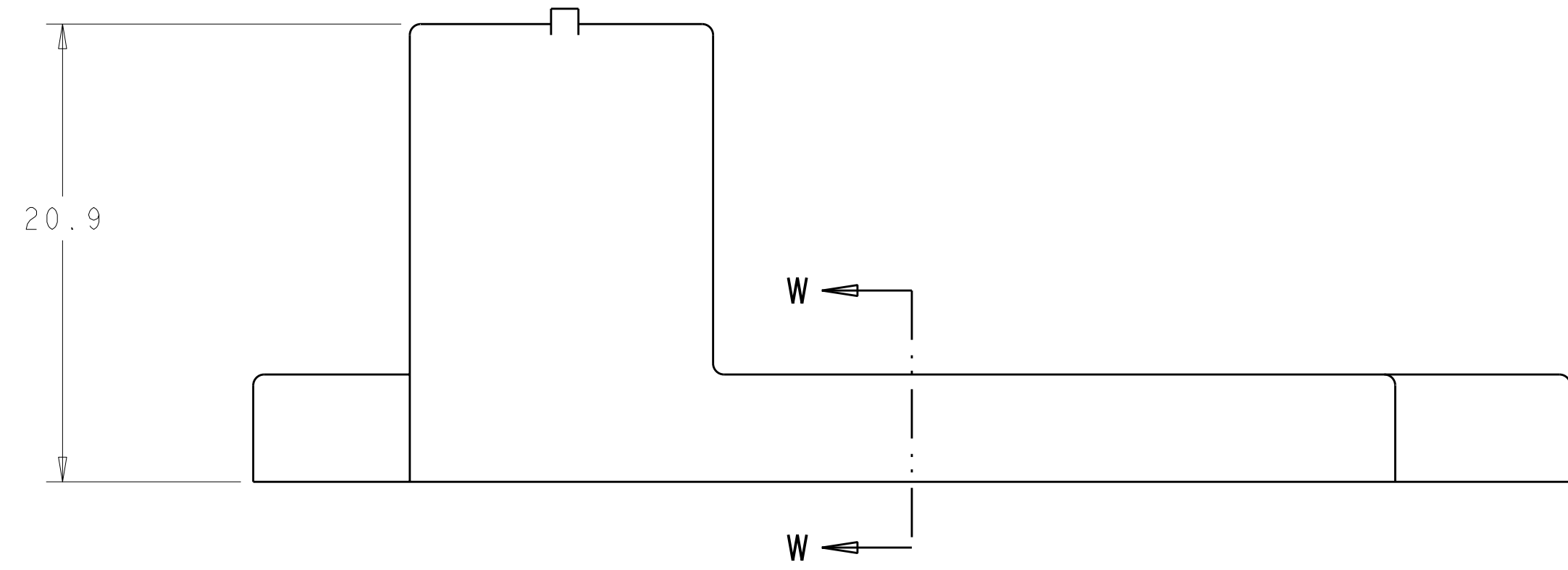

SECTION W-W

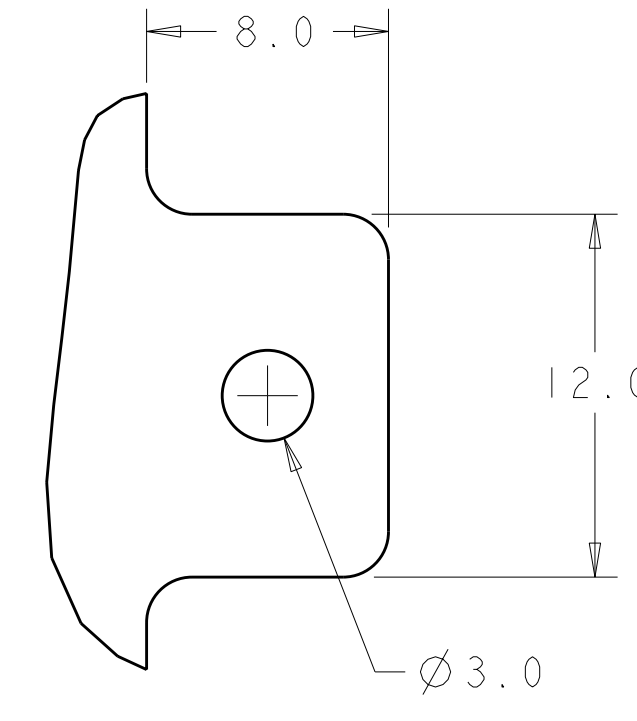

DETAIL X SCALE 4:1

52 POSITION CONNECTOR FIXTURE
 (SHOWN WITH CLEARANCE FOR ALL KEY OPTIONS)

- CONNECTOR FIXTURE SHOULD BE USED TO VERIFY THE RECEPTACLE CARRIER IS PROPERLY SEATED AND LOCKED INTO THE SHIELD ASSEMBLY. THE CONNECTOR WILL NOT FULLY MATE TO THE FIXTURE IF THE RECEPTACLE CARRIER IS OUT OF POSITION.
- RECOMMEND USING A SENSING DEVICE FOR VERIFYING FULLY MATED CONNECTORS. SUCH A DEVICE IS AT THE CUSTOMERS DISCRETION.
- RECOMMENDED MATERIAL: HARDENED STEEL
- NO RADII OR CHAMFER PERMITTED IN SPECIFIED AREA. MUST MAINTAIN 90° EDGE.
- RADII TO BE 0.5 UNLESS OTHERWISE SPECIFIED.
- OPTIONAL CONSTRAINT FEATURE.

DIMENSIONS: mm TOLERANCES UNLESS OTHERWISE SPECIFIED: 9 PLC ± 1 PLC ±0.2 3 PLC ±0.05 4 PLC ± ANGLES ± FINISH ±1*		DWN T. WOOTEN 07JUL2000 CHK C. MARTIN 07JUL2000 APVD D. KLEIN 07JUL2000	Tyco Electronics Harrisburg, PA 17105-3608
MATERIAL: Δ		NAME: SHIELD ASSEMBLY, 52 POSITION, LEVER ASSISTED CONNECTOR	SIZE: CAGE CODE: DRAWING NO: RESTRICTED TO:
CUSTOMER DRAWING		WEIGHT: - SCALE: 4:1	SHEET 2 OF 2 REV B1