



Chipsmall Limited consists of a professional team with an average of over 10 year of expertise in the distribution of electronic components. Based in Hongkong, we have already established firm and mutual-benefit business relationships with customers from,Europe,America and south Asia,supplying obsolete and hard-to-find components to meet their specific needs.

With the principle of “Quality Parts,Customers Priority,Honest Operation,and Considerate Service”,our business mainly focus on the distribution of electronic components. Line cards we deal with include Microchip,ALPS,ROHM,Xilinx,Pulse,ON,Everlight and Freescale. Main products comprise IC,Modules,Potentiometer,IC Socket,Relay,Connector.Our parts cover such applications as commercial,industrial, and automotives areas.

We are looking forward to setting up business relationship with you and hope to provide you with the best service and solution. Let us make a better world for our industry!



## Contact us

Tel: +86-755-8981 8866 Fax: +86-755-8427 6832

Email & Skype: info@chipsmall.com Web: www.chipsmall.com

Address: A1208, Overseas Decoration Building, #122 Zhenhua RD., Futian, Shenzhen, China



PART NUMBER	ITEM ① BODY	ITEM ② BASE	ITEM ③ INSULATOR	ITEM ④ INSULATOR	ITEM ⑤ CONTACT
135-9701-311	COPPER ALLOY GOLD PL .00005 MIN OVER COPPER PL .00005 MIN	COPPER ALLOY GOLD PL .00005 MIN OVER COPPER PL .00005 MIN	TEFLON	TEFLON	BERYLLIUM COPPER GOLD PL .00005 MIN OVER COPPER PL .00005 MIN

DRAWING NO. C - 135-9701-311/320	
0	REVISIONS
ENGINEERING RELEASE	
1	10-6-08 P A T W B T A K J U S 10-13-08 ECN 51659

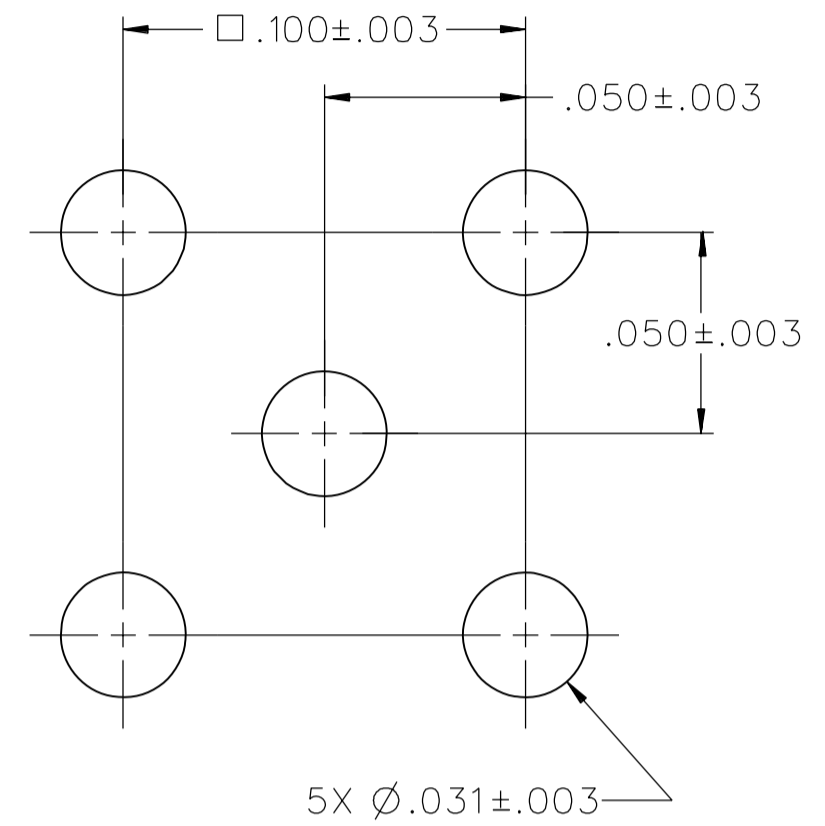
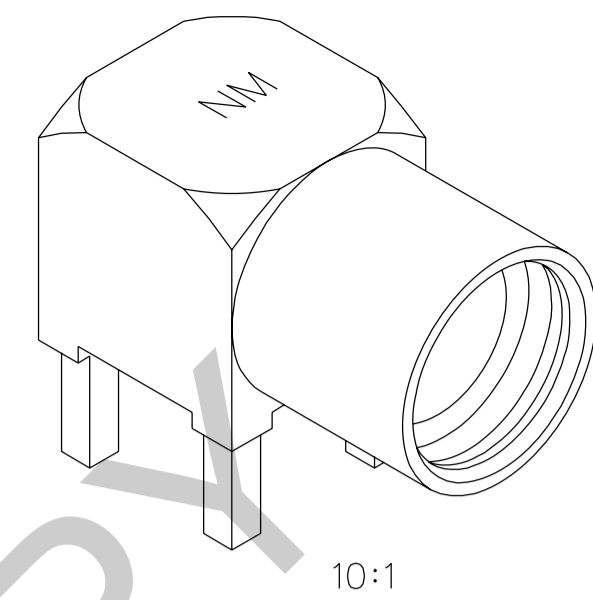

MOUNTING HOLE LAYOUT

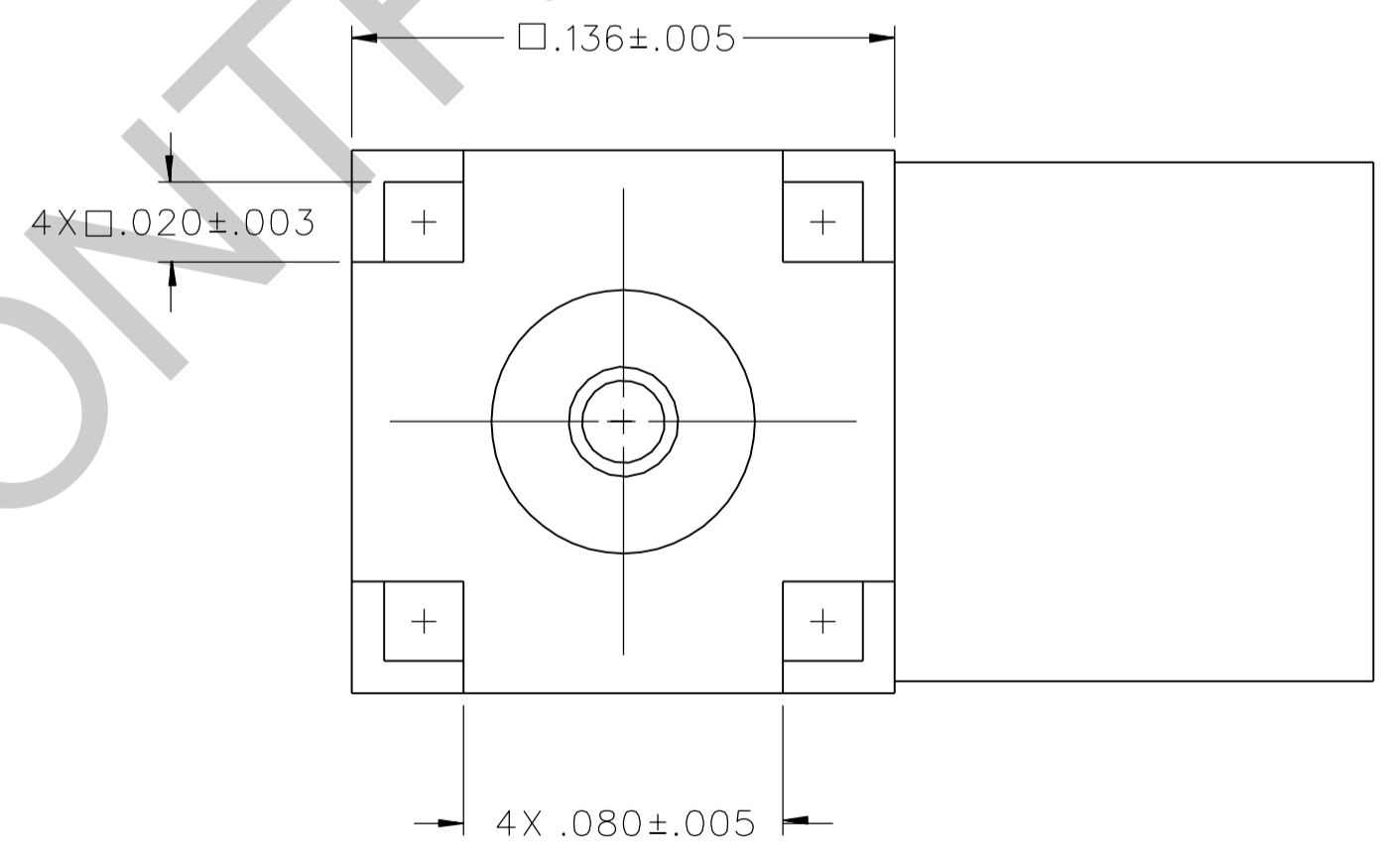
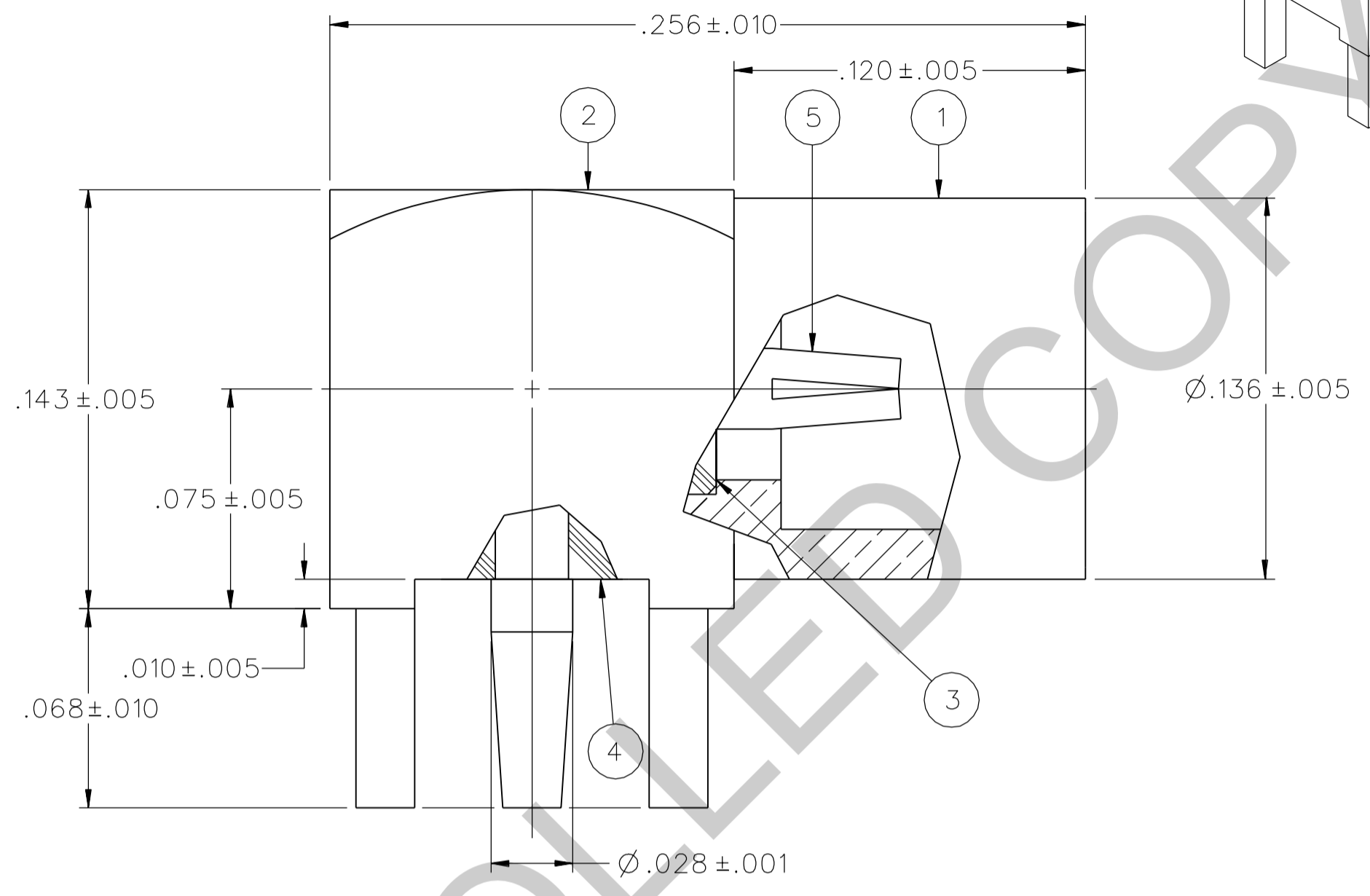

NOTES:

- SPECIFICATIONS:
  - IMPEDANCE: 50 OHMS
  - FREQUENCY RANGE: 0-6 GHz
  - VSWR: NOT APPLICABLE
  - WORKING VOLTAGE: 170 VRMS MAX AT SEA LEVEL
  - DIELECTRIC WITHSTANDING VOLTAGE: 500 VRMS MIN AT SEA LEVEL
  - INSULATION RESISTANCE: 1000 MEGOHM MIN
  - CONTACT RESISTANCE:
    - CENTER CONTACT - INITIAL 5.0 MILLIOHM MAX, AFTER ENVIRONMENTAL 8.0 MILLIOHM MAX
    - OUTER CONDUCTOR - GOLD PLATED INITIAL 1 MILLIOHM MAX, AFTER ENVIRONMENTAL 1.5 MILLIOHM MAX
    - NICKEL PLATED INITIAL 2.5 MILLIOHM MAX, AFTER ENVIRONMENTAL 3.5 MILLIOHM MAX
  - BRAID TO BODY - NOT APPLICABLE
  - CORONA LEVEL: 190 VOLTS MINIMUM AT 70,000 FEET
  - INSERTION LOSS: NOT APPLICABLE
  - RF LEAKAGE: NOT APPLICABLE
  - RF HIGH POTENTIAL WITHSTANDING VOLTAGE: 400 VRMS AT 4 AND 7 MHZ
- MECHANICAL:
  - ENGAGE/DISENGAGE FORCE: 8.0 LBS MAX ENGAGEMENT, 1.4 LBS MIN DISENGAGEMENT
  - CONTACT RETENTION FORCE: NOT APPLICABLE
  - CONTACT RETENTION TORQUE: NOT APPLICABLE
  - COUPLING MECHANISM RETENTION: NOT APPLICABLE
  - CABLE ACCEPTABILITY: NOT APPLICABLE
  - CABLE HEX CRIMP SIZE: NOT APPLICABLE
  - CABLE RETENTION: NOT APPLICABLE
  - DURABILITY: 500 CYCLES MIN
- ENVIRONMENTAL:
  - (MEETS OR EXCEEDS THE APPLICABLE PARAGRAPH OF MIL-PRF-39012)
  - THERMAL SHOCK: MIL-STD-202, METHOD 107, CONDITION C EXCEPT -55 DEG C TO 155 DEG C
  - OPERATING TEMPERATURE: -55 DEG C TO 155 DEG C
  - CORROSION: MIL-STD-202, METHOD 101, CONDITION B
  - SHOCK: MIL-STD-202, METHOD 213, CONDITION B
  - VIBRATION: MIL-STD-202, METHOD 204, CONDITION D
  - MOISTURE: MIL-STD-202, METHOD 106

CUSTOMER DRAWING  
THIS DRAWING TO BE INTERPRETED PER ASME Y 14.5M - 1994  
"μSTATION"  
COMPANY CONFIDENTIAL

TOLERANCE UNLESS OTHERWISE SPECIFIED		DRAWN BY BTW	DATE 4-16-08		<b>Cinch</b> CONNECTIVITY SOLUTIONS a bel group	Cinch Connectivity Solutions P.O. Box 1732 Waseca, MN 56093 1-800-247-8256	
DECIMALS	mm	CHECKED BY TJS	DATE 10-13-08			TITLE ASSEMBLY JACK RIGHT ANGLE PC MOUNT NON-MAGNETIC MMCX	
.XX	_____	APPROVED BY TAK	DATE 10-13-08	SHEET 2 OF 2		DRAWING NO. C - 135-9701-311/320	
.XXX	_____	RELEASE DATE	10-13-08	U/M		INCH	
MATL	_____	SCALE		20:1			
FINISH	_____						