



Chipsmall Limited consists of a professional team with an average of over 10 year of expertise in the distribution of electronic components. Based in Hongkong, we have already established firm and mutual-benefit business relationships with customers from,Europe,America and south Asia,supplying obsolete and hard-to-find components to meet their specific needs.

With the principle of “Quality Parts,Customers Priority,Honest Operation,and Considerate Service”,our business mainly focus on the distribution of electronic components. Line cards we deal with include Microchip,ALPS,ROHM,Xilinx,Pulse,ON,Everlight and Freescale. Main products comprise IC,Modules,Potentiometer,IC Socket,Relay,Connector.Our parts cover such applications as commercial,industrial, and automotives areas.

We are looking forward to setting up business relationship with you and hope to provide you with the best service and solution. Let us make a better world for our industry!



Contact us

Tel: +86-755-8981 8866 Fax: +86-755-8427 6832

Email & Skype: info@chipsmall.com Web: www.chipsmall.com

Address: A1208, Overseas Decoration Building, #122 Zhenhua RD., Futian, Shenzhen, China



DRAWING NO.
C - 138-4407-001/010

0 REVISIONS

ENGINEERING RELEASE

1	11-30-05	PAT	JRK	PDW	MJU	4-7-06	ECN 50011
---	----------	-----	-----	-----	-----	--------	-----------

PART NUMBER	ITEM ① BODY	ITEM ② CONTACT	ITEM ③ INSULATOR	ITEM ④ COUPLING NUT	ITEM ⑤ RETENTION SPRING	ITEM ⑥ SEAL GASKET	ITEM ⑦ CRIMP SLEEVE
138-4407-006	BRASS NICKEL PL .0001 MIN OVER COPPER PL .00005 MIN	BRASS GOLD PL .00005 MIN OVER NICKEL PL .00005 MIN OVER COPPER PL .00005 MIN	TEFLON	BRASS NICKEL PL .0001 MIN OVER COPPER PL .00005 MIN	BERYLLIUM COPPER UNPLATED	SILICONE RUBBER	COPPER NICKEL PL .0001 MIN OVER COPPER PL .00005 MIN
138-4407-007	BRASS TRI-ALLOY PL .0001 MIN	BRASS GOLD PL .00005 MIN OVER NICKEL PL .00005 MIN OVER COPPER PL .00005 MIN	TEFLON	BRASS TRI-ALLOY PL .0001 MIN	BERYLLIUM COPPER UNPLATED	SILICONE RUBBER	COPPER TRI-ALLOY PL .0001 MIN

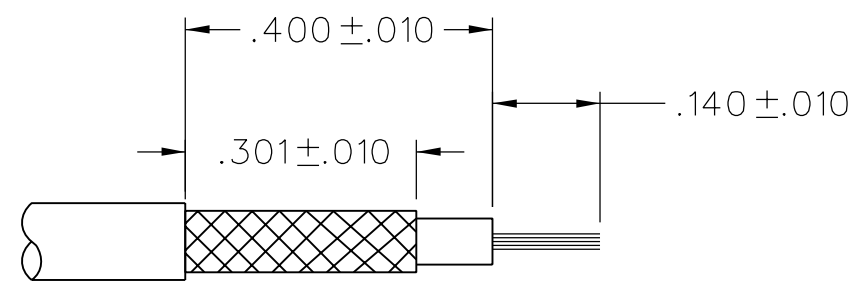
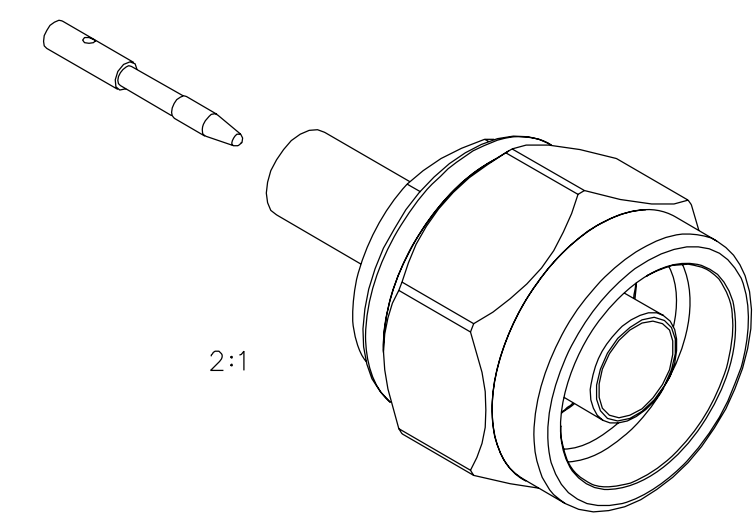
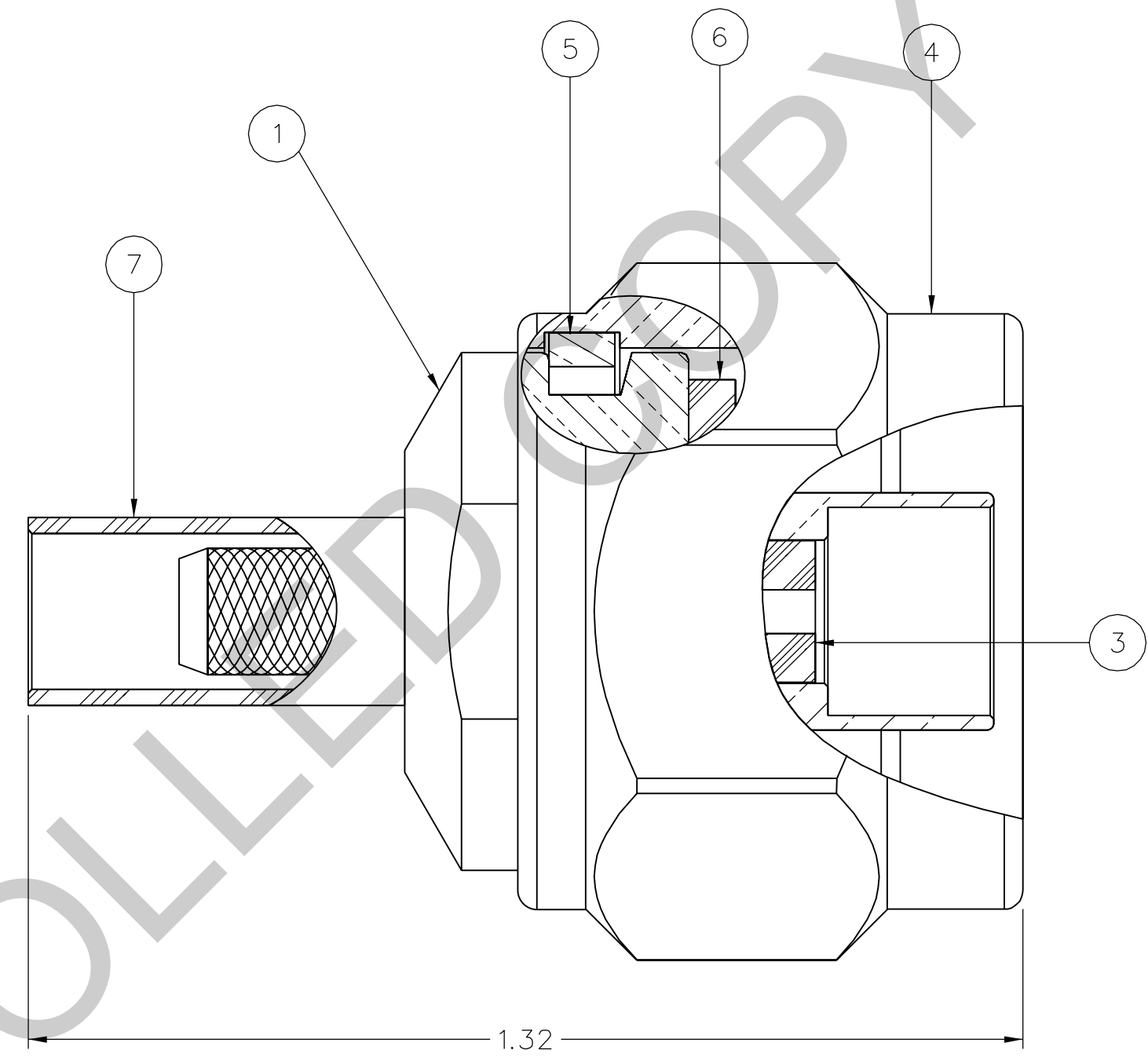
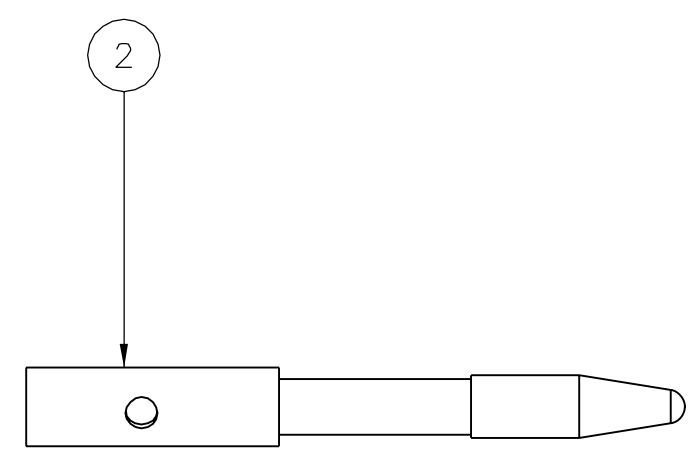
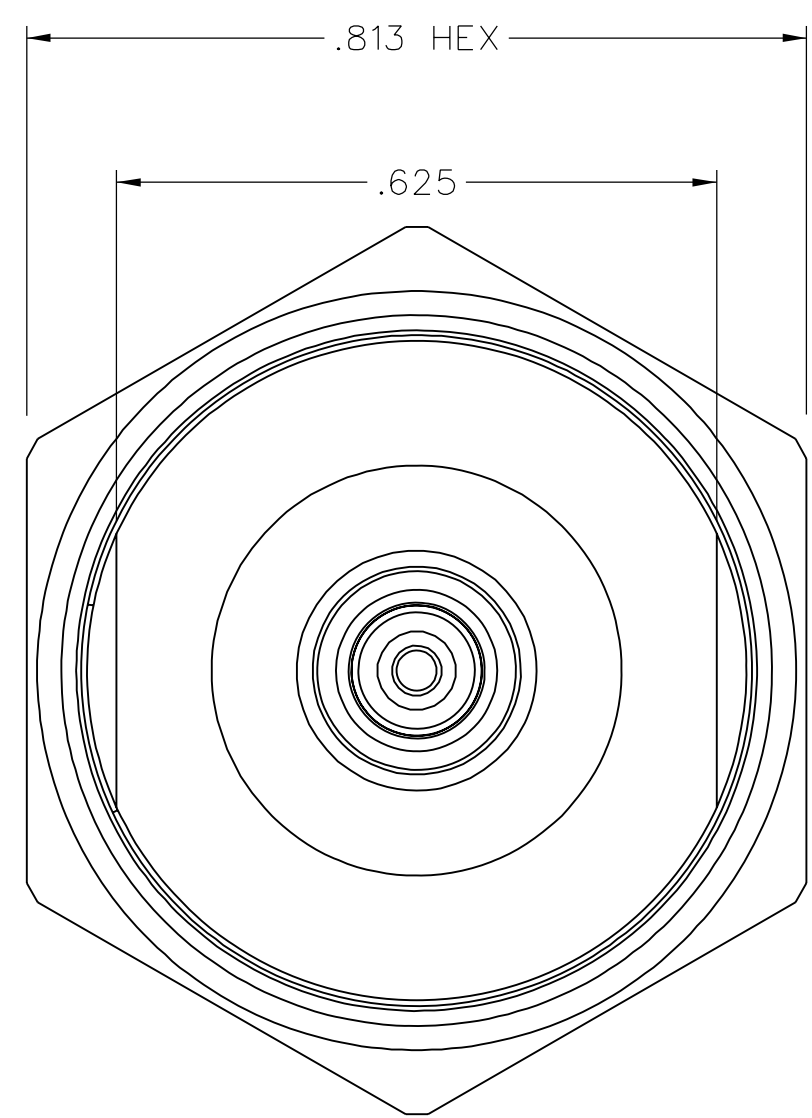

CABLE STRIP DIMENSIONS

NOT TO SCALE

NOTES:

1. SPECIFICATIONS:
- IMPEDANCE: 50 OHMS
 - FREQUENCY RANGE: 0-11 GHz
 - VSWR: 1.30 MAX AT 0-11 GHz
 - WORKING VOLTAGE: 335 VRMS MAX AT SEA LEVEL
 - DIELECTRIC WITHSTANDING VOLTAGE: 1000 VRMS MIN AT SEA LEVEL
 - INSULATION RESISTANCE: 5000 MEGOHM MIN
 - CONTACT RESISTANCE:
 - CENTER CONTACT - INITIAL 1.0 MILLIOHM MAX, AFTER ENVIRONMENTAL 1.5 MILLIOHM MAX
 - OUTER CONDUCTOR - INITIAL 0.2 MILLIOHM MAX, AFTER ENVIRONMENTAL NOT APPLICABLE
 - BODY TO CABLE - 0.05 MILLIOHM MAX, AFTER ENVIRONMENTAL NOT APPLICABLE
 - CORONA LEVEL: 250 VOLTS MIN AT 70,000 FEET
 - INSERTION LOSS: 0.15 dB MAX, TESTED AT 9 GHz
 - RF LEAKAGE: -90 dB MIN AT 2 TO 3 GHz
 - RF HIGH POTENTIAL WITHSTANDING VOLTAGE: 670 VRMS AT 4 AND 7 MHz
 - THIRD ORDER INTERMODULATION PRODUCT (IMP3): TYPICALLY < -90 dBm (TESTED PER IEC GUIDELINES WITH 20W CW INPUTS AT 1930-1990 MHz)

- MECHANICAL:
- ENGAGE/DISENGAGE TORQUE: 6 IN-LBS MAX
 - MATING TORQUE: 7-10 IN-LBS
 - COUPLING PROOF TORQUE: 15 IN-LBS MIN
 - COUPLING NUT RETENTION: 100 LBS MIN
 - CONTACT RETENTION: NOT APPLICABLE
 - CABLE ACCEPTABILITY: RG 58, RG 141, RG 303
 - CABLE HEX CRIMP SIZE: .213
 - CONTACT HEX CRIMP SIZE: .068
 - CABLE RETENTION: 40 LBS MIN AXIAL FORCE
 - DURABILITY: 500 CYCLES MIN

- ENVIRONMENTAL:
- (MEETS OR EXCEEDS THE APPLICABLE PARAGRAPH OF MIL-PRF-39012)
 - THERMAL SHOCK: MIL-STD-202, METHOD 107, CONDITION B, EXCEPT 85°C HIGH TEMP
 - OPERATING TEMPERATURE: -65°C TO 165°C
 - CORROSION: MIL-STD-202, METHOD 101, CONDITION B
 - SHOCK: MIL-STD-202, METHOD 213, CONDITION I
 - VIBRATION: MIL-STD-202, METHOD 204, CONDITION B
 - MOISTURE RESISTANCE: MIL-STD-202, METHOD 106

CUSTOMER DRAWING

THIS DRAWING TO BE INTERPRETED PER ASME Y 14.5M - 1994

"μSTATION"

COMPANY CONFIDENTIAL

TOLERANCE UNLESS OTHERWISE SPECIFIED	DRAWN BY PAT	DATE 11-11-05
DECIMALS .XX REF	CHECKED BY PDW	DATE 4-6-06
.XXX REF	APPROVED BY JRK	DATE 4-6-06
MATL	RELEASE DATE	4-7-06
FINISH	U/M INCH	SCALE 5:1

	Cinch Connectivity Solutions P.O. Box 1732 Waseca, MN 56093 1-800-247-8256	
	TITLE STRAIGHT CRIMP PLUG, TYPE N CONNECTOR, RG58 FLEXIBLE CABLED	
SHEET 2 OF 2	DRAWING NO. C - 138-4407-001/010	