



Chipsmall Limited consists of a professional team with an average of over 10 year of expertise in the distribution of electronic components. Based in Hongkong, we have already established firm and mutual-benefit business relationships with customers from,Europe,America and south Asia,supplying obsolete and hard-to-find components to meet their specific needs.

With the principle of "Quality Parts,Customers Priority,Honest Operation,and Considerate Service",our business mainly focus on the distribution of electronic components. Line cards we deal with include Microchip,ALPS,ROHM,Xilinx,Pulse,ON,Everlight and Freescale. Main products comprise IC,Modules,Potentiometer,IC Socket,Relay,Connector.Our parts cover such applications as commercial,industrial, and automotives areas.

We are looking forward to setting up business relationship with you and hope to provide you with the best service and solution. Let us make a better world for our industry!



Contact us

Tel: +86-755-8981 8866 Fax: +86-755-8427 6832

Email & Skype: info@chipsmall.com Web: www.chipsmall.com

Address: A1208, Overseas Decoration Building, #122 Zhenhua RD., Futian, Shenzhen, China



PART NUMBER 140-0000-972	ITEM ① HANDLE STAINLESS STEEL PASSIVATED	ITEM ② BUSHING BRASS NICKEL PL .0001 MIN OVER COPPER PL .00005 MIN	APPLICATION CABLE CLAMPING VISE 140-0000-962
-----------------------------	---	--	--

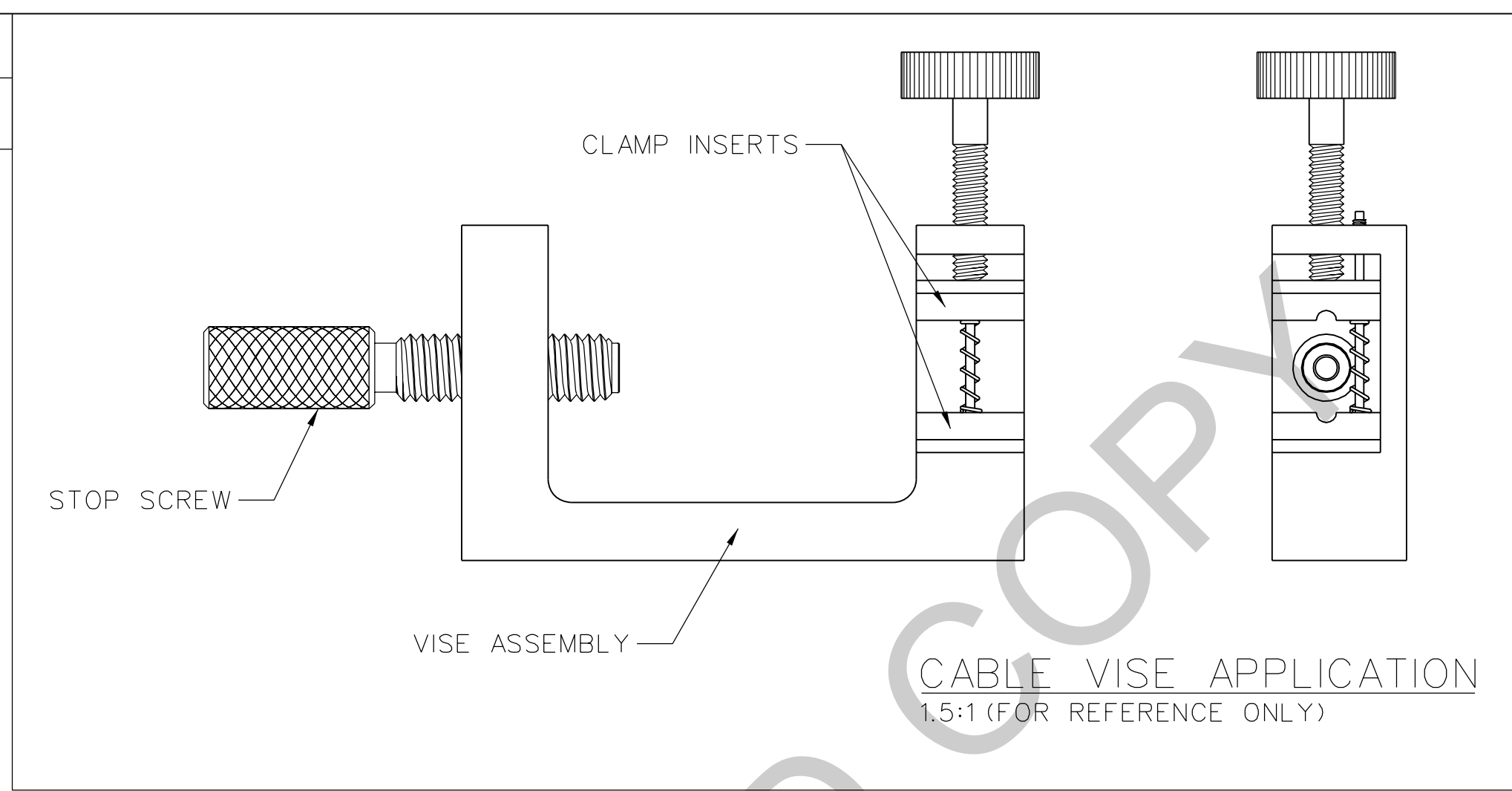
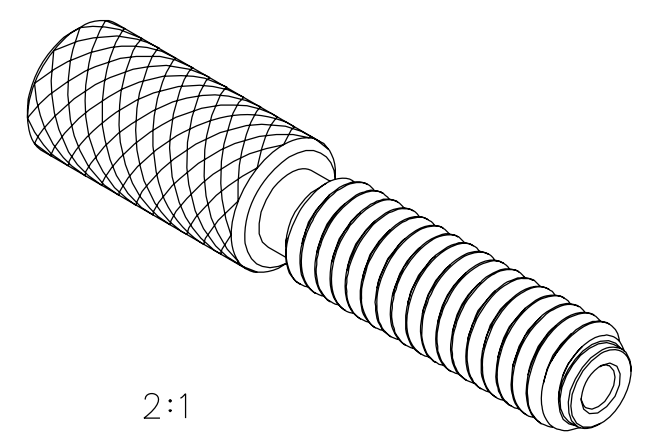

DRAWING NO. C-140-0000-972				
0 REVISIONS				
ENGINEERING RELEASE				
1	5-3-06	P A T	J R K	M J U
				7-20-06 ECN 50426

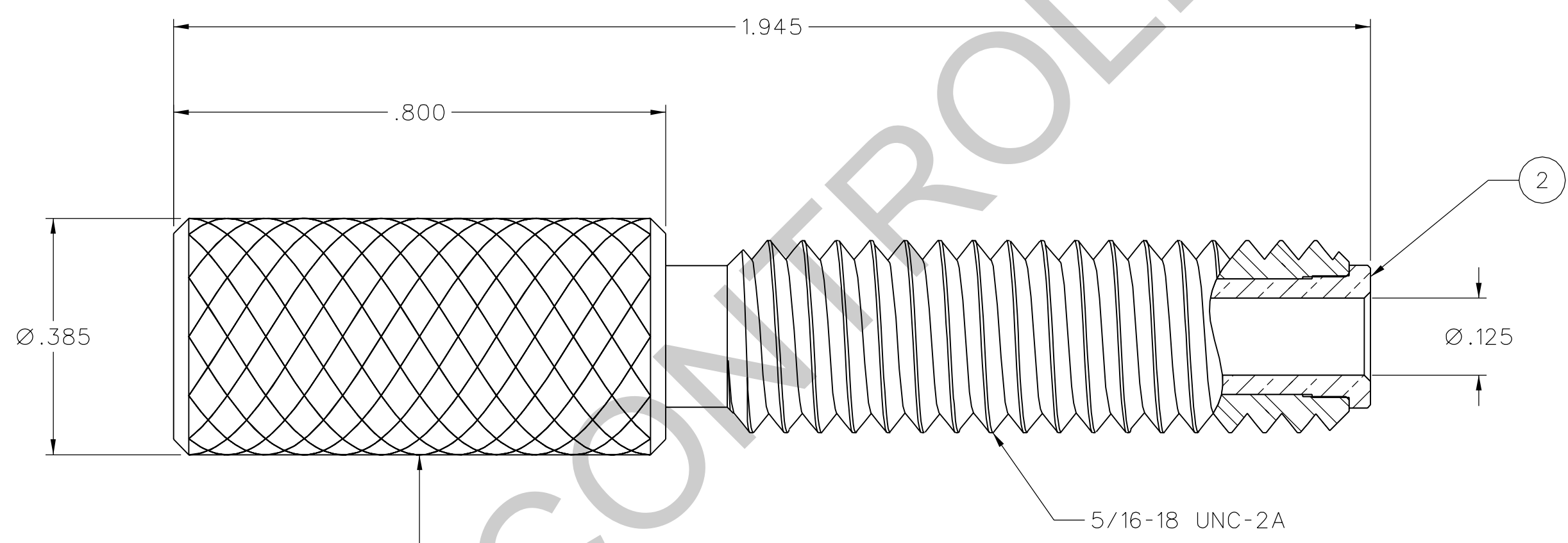

NOTES:

1. THIS STOP SCREW IS TO BE USED IN CONJUNCTION WITH THE SEMI-RIGID CABLE SOLDERING VISE, AS SHOWN IN THE APPLICATION DETAIL. REFER TO THE APPROPRIATE CONNECTOR ASSEMBLY INSTRUCTIONS FOR PROPER USAGE.

CUSTOMER DRAWING

THIS DRAWING TO BE INTERPRETED
PER ASME Y 14.5M - 1994

"μSTATION"

COMPANY CONFIDENTIAL

TOLERANCE UNLESS OTHERWISE SPECIFIED		DRAWN BY JRK	DATE 1-9-06	 Cinch CONNECTIVITY SOLUTIONS a bel group	Cinch Connectivity Solutions P.O. Box 1732 Waseca, MN 56093 1-800-247-8256	
DECIMALS	mm	CHECKED BY PDW	DATE 7-19-06		TITLE TYPE N BULKHEAD JACK CABLE SOLDERING VISE STOP SCREW	
.XX	—	APPROVED BY JRK/MJU	DATE 7-19-06	SHEET 2 OF 2		
.XXX	REF	RELEASE DATE 7-20-06	SCALE 5:1	DRAWING NO. C-140-0000-972		
MATL	—					
FINISH	—					