



Chipsmall Limited consists of a professional team with an average of over 10 year of expertise in the distribution of electronic components. Based in Hongkong, we have already established firm and mutual-benefit business relationships with customers from,Europe,America and south Asia,supplying obsolete and hard-to-find components to meet their specific needs.

With the principle of “Quality Parts,Customers Priority,Honest Operation,and Considerate Service”,our business mainly focus on the distribution of electronic components. Line cards we deal with include Microchip,ALPS,ROHM,Xilinx,Pulse,ON,Everlight and Freescale. Main products comprise IC,Modules,Potentiometer,IC Socket,Relay,Connector.Our parts cover such applications as commercial,industrial, and automotives areas.

We are looking forward to setting up business relationship with you and hope to provide you with the best service and solution. Let us make a better world for our industry!



Contact us

Tel: +86-755-8981 8866 Fax: +86-755-8427 6832

Email & Skype: info@chipsmall.com Web: www.chipsmall.com

Address: A1208, Overseas Decoration Building, #122 Zhenhua RD., Futian, Shenzhen, China



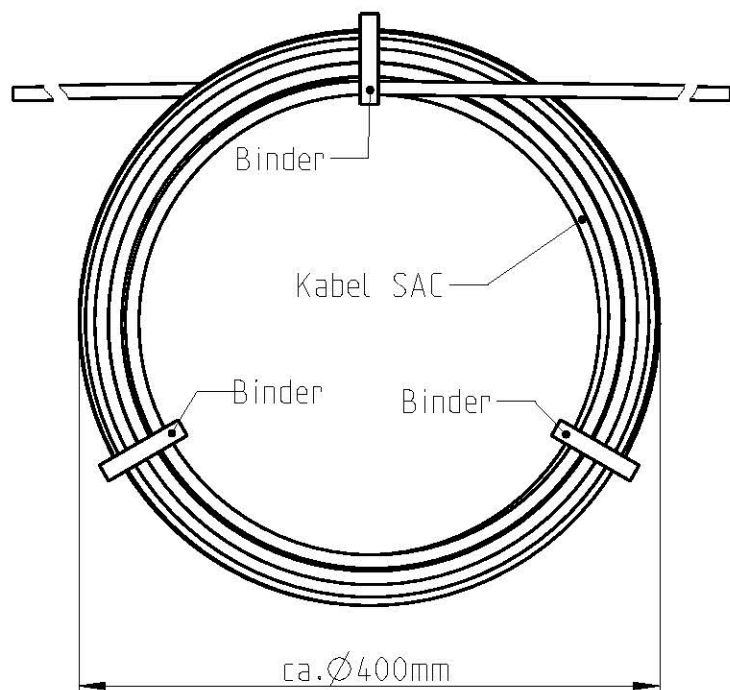

- Kabel alle 5 Meter mit kompletter Artikelbezeichnung bedrucken
- Kabelring wie dargestellt Punktfixieren

Bedruckung:

KW/Jahr
immer aktuell!

PHOENIX CONTACT Art.-Nr. 1405789 100,0m 35T 12x0,14 KW/JJ

Kabellänge		Toleranz
über	bis	
	1m	±15mm
1m	9m	±45mm
9m	18m	±70mm
18m		±110mm

						Datum	Name	Freimaßtoleranzen nach DIN ISO 2768 - c	Technische Änderungen vorbehalten	Maßstab: 3:10
						Bearb.	2012-05-22	Thumm		
						Gepr.			Dok-Nr.:	00663515
						DIN A4		Artikelbezeichnung:	SAC-12P-100,0-35T/SH-0,14	
								Artikel-Nr.:	1405789	
								Zeichnungs-Nr.:	PB-1413804	
Index	Datum	Änderung	Name	Geprüft	Name					