



Chipsmall Limited consists of a professional team with an average of over 10 year of expertise in the distribution of electronic components. Based in Hongkong, we have already established firm and mutual-benefit business relationships with customers from,Europe,America and south Asia,supplying obsolete and hard-to-find components to meet their specific needs.

With the principle of “Quality Parts,Customers Priority,Honest Operation,and Considerate Service”,our business mainly focus on the distribution of electronic components. Line cards we deal with include Microchip,ALPS,ROHM,Xilinx,Pulse,ON,Everlight and Freescale. Main products comprise IC,Modules,Potentiometer,IC Socket,Relay,Connector.Our parts cover such applications as commercial,industrial, and automotives areas.

We are looking forward to setting up business relationship with you and hope to provide you with the best service and solution. Let us make a better world for our industry!



Contact us

Tel: +86-755-8981 8866 Fax: +86-755-8427 6832

Email & Skype: info@chipsmall.com Web: www.chipsmall.com

Address: A1208, Overseas Decoration Building, #122 Zhenhua RD., Futian, Shenzhen, China



DC charging cable - EV-T2M4CC-DC125A-4,5M50ESBK00 - 1408003

Please be informed that the data shown in this PDF Document is generated from our Online Catalog. Please find the complete data in the user's documentation. Our General Terms of Use for Downloads are valid (<http://phoenixcontact.com/download>)



DC charging cable with Vehicle Connector and open cable end, CCS type 2, Combined Charging System, IEC 62196-3, 125 A / 1000 V (DC), Cable data: 4.5 m, black, straight

Product Description

DC charging cable, with Vehicle Connector and open cable end for fast charging electric vehicles with direct current (DC) via a CCS type 2 Vehicle Inlet, for installation at charging stations (EVSE)



Key Commercial Data

Packing unit	1 pc
Custom tariff number	85444290
Country of origin	Germany

Technical data

Product definition

Product type	DC charging cable with Vehicle Connector and open cable end
Standards/regulations	IEC 62196-3
Charging standard	CCS type 2
	Combined Charging System
Charging mode	Mode 4
Type of charging current	DC

Dimensions

Conductor length	4.5 m
Width	75 mm
Height	139 mm
Length	267 mm

Features

Charging power	125 kW
----------------	--------

DC charging cable - EV-T2M4CC-DC125A-4,5M50ESBK00 - 1408003

Technical data

Features

Rated current for power contacts	125 A
Rated voltage for power contacts	1000 V DC
Rated current for signal contacts	2 A
Rated voltage for signal contacts	30 V AC
Type of signal transmission	Pulse width modulation with modulated Powerline communication according to ISO/IEC 15118 / DIN SPEC 70121
Temperature monitoring	2x Pt 1000
Number of power contacts	3 (PE, DC+, DC-)
Number of signal contacts	2 (CP, PP)
Connection method	Crimp connection, cannot be separated
Resistor coding	1500 Ω (between PE and PP)
Insertion force	< 100 N
Withdrawal force	< 100 N
Insertion/withdrawal cycles	> 10000
Ambient temperature (operation)	-30 °C ... 50 °C (Operation)
Ambient temperature (storage/transport)	-40 °C ... 80 °C (Storage)
Altitude difference for area of application	5000 m (above sea level)
Degree of protection	IP44 (plugged in)
	IP20 (not plugged in, IP24 should be ensured by the charging station)

Cable

Cable structure	2 x 50 mm ² + 1 x 25 mm ² + 3 x 2 x 0.75 mm ² (EN 60228 class 6)
External cable diameter	28.2 mm ±0.2 mm
Type of conductor	straight
Outer sheath, material	HFFR
External sheath, color	black
Minimum bending radius	140 mm (5 x diameter)

Design

Housing color	black
Pin connector pattern color	gray
Label	14.1 mm x 44.8 mm (customer logo possible)

Material

Housing material	PBT
Material surface of contacts	Silver Ag

DC charging cable - EV-T2M4CC-DC125A-4,5M50ESBK00 - 1408003

Classifications

eCl@ss

eCl@ss 4.0	272607xx
eCl@ss 4.1	27260701
eCl@ss 5.0	27260701
eCl@ss 5.1	27260701
eCl@ss 6.0	27279220
eCl@ss 7.0	27060390
eCl@ss 8.0	27440590
eCl@ss 9.0	27144705

ETIM

ETIM 3.0	EC002061
ETIM 4.0	EC002061
ETIM 5.0	EC002839

UNSPSC

UNSPSC 6.01	30211923
UNSPSC 7.0901	39121522
UNSPSC 11	39121522
UNSPSC 12.01	39121522
UNSPSC 13.2	39121522

Approvals

Approvals

Approvals

VDE Zeichengenehmigung

Ex Approvals

Approvals submitted

Approval details

DC charging cable - EV-T2M4CC-DC125A-4,5M50ESBK00 - 1408003

Approvals

VDE Zeichengenehmigung	
Nominal current I _N	125 A
Nominal voltage U _N	1000 V

Drawings

Schematic diagram

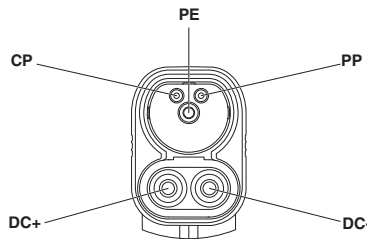

Pin assignment of the Vehicle Connector

Dimensional drawing

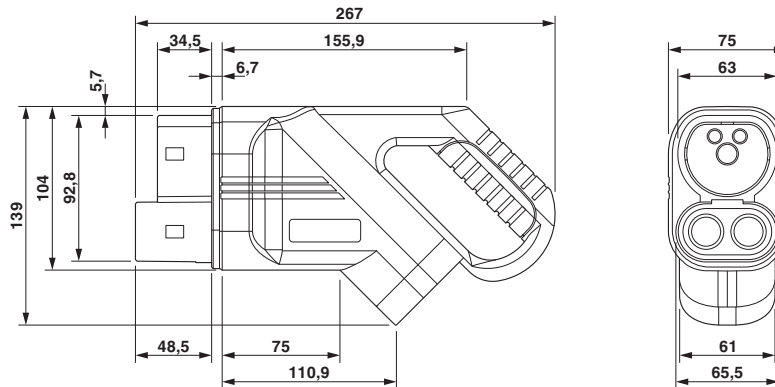

Dimensional drawing of Vehicle Connector

DC charging cable - EV-T2M4CC-DC125A-4,5M50ESBK00 - 1408003

Schematic diagram

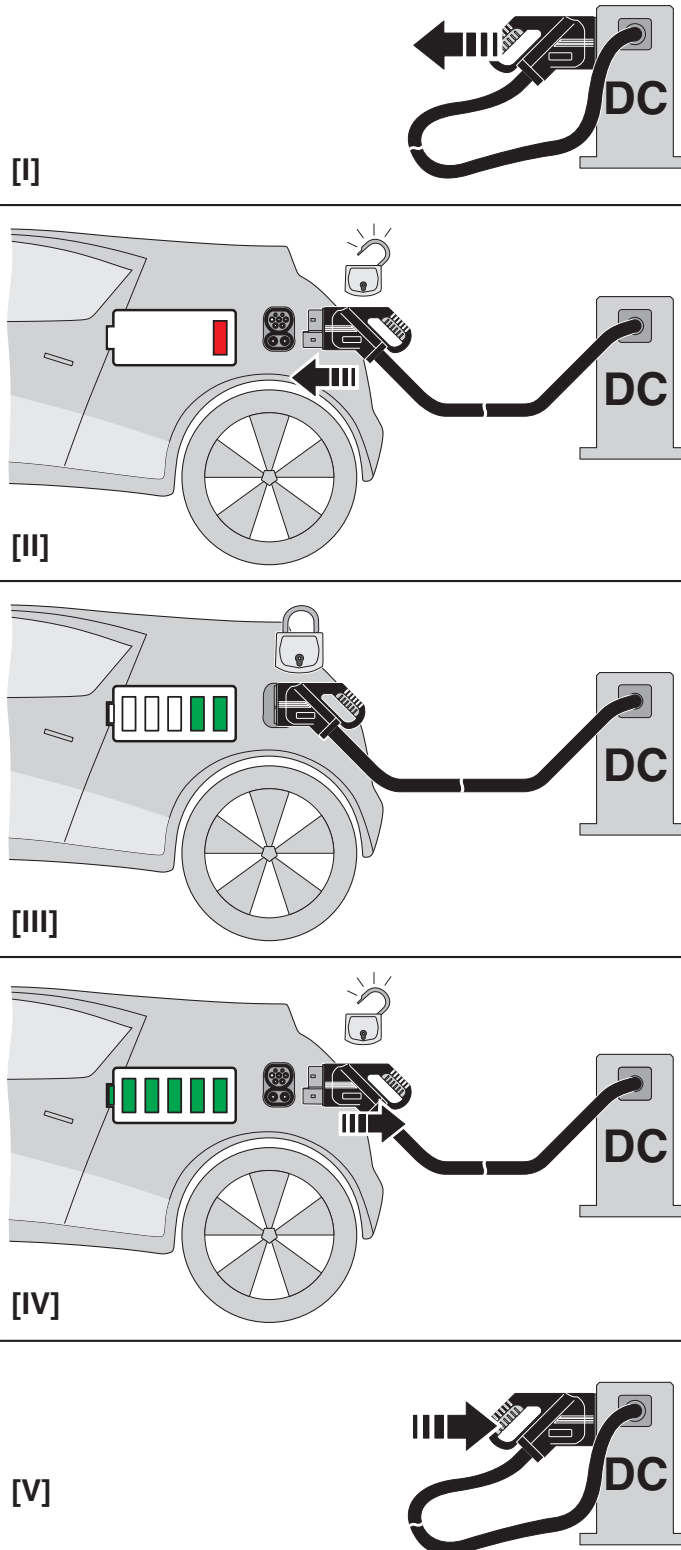

DC charging cable - EV-T2M4CC-DC125A-4,5M50ESBK00 - 1408003

Schematic diagram

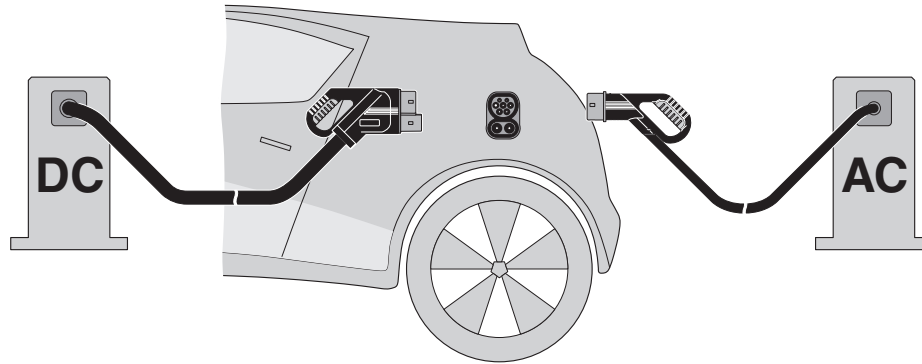

The Combined Charging System (CCS) principle - standard-compliant charging system for electric vehicles, which supports both conventional AC charging and fast DC charging. Both Vehicle Connectors fit into the CCS Vehicle Inlet.