



Chipsmall Limited consists of a professional team with an average of over 10 year of expertise in the distribution of electronic components. Based in Hongkong, we have already established firm and mutual-benefit business relationships with customers from,Europe,America and south Asia,supplying obsolete and hard-to-find components to meet their specific needs.

With the principle of “Quality Parts,Customers Priority,Honest Operation,and Considerate Service”,our business mainly focus on the distribution of electronic components. Line cards we deal with include Microchip,ALPS,ROHM,Xilinx,Pulse,ON,Everlight and Freescale. Main products comprise IC,Modules,Potentiometer,IC Socket,Relay,Connector.Our parts cover such applications as commercial,industrial, and automotives areas.

We are looking forward to setting up business relationship with you and hope to provide you with the best service and solution. Let us make a better world for our industry!



## Contact us

Tel: +86-755-8981 8866 Fax: +86-755-8427 6832

Email & Skype: info@chipsmall.com Web: www.chipsmall.com

Address: A1208, Overseas Decoration Building, #122 Zhenhua RD., Futian, Shenzhen, China



## Socket Outlet - EV-T2M3SE24-3AC32A-0,5M6,0E11 - 1409681

Please be informed that the data shown in this PDF Document is generated from our Online Catalog. Please find the complete data in the user's documentation. Our General Terms of Use for Downloads are valid (<http://phoenixcontact.com/download>)



Infrastructure Socket Outlet for charging electric vehicles with alternating current (AC), compatible with Infrastructure Plugs, Type 2, IEC 62196-2, 32 A / 480 V (AC), 24 V Locking actuator, Single wires, Length: 0.5 m, Thread: M5, Screw connection of a hinged cover: Only rear mounting possible

### Product Description

Infrastructure Socket Outlet for charging electric vehicles (EV) with alternating current (AC), compatible with type 2 Infrastructure Plugs, for installation at charging stations for E-Mobility (EVSE)



### Key Commercial Data

Packing unit	1 STK
Weight per Piece (excluding packing)	780.0 g
Custom tariff number	85444290
Country of origin	Germany

### Technical data

#### Product definition

Product type	Infrastructure Socket Outlet for charging electric vehicles with alternating current (AC), compatible with Infrastructure Plugs
Standards/regulations	IEC 62196-2
Charging standard	Type 2
Charging mode	Mode 3
Type of charging current	AC 3-phase
Note	Rear screw connection for an optional hinged cover supported

#### Dimensions

Height	96 mm
Width	75 mm
Depth	76.2 mm

# Socket Outlet - EV-T2M3SE24-3AC32A-0,5M6,0E11 - 1409681

## Technical data

### Dimensions

Bore dimensions	60 mm x 60 mm
Conductor length	0.50 m
Cable length of locking actuator	0.50 mm
Cable structure	5x 6.0 mm <sup>2</sup> + 2x 0.5 mm <sup>2</sup>
Type of conductor	Single wires

### Ambient conditions

Ambient temperature (operation)	-30 °C ... 50 °C
Ambient temperature (storage/transport)	-40 °C ... 80 °C
Max. altitude	5000 m (above sea level)
Degree of protection	IP44 (plugged in)
	IP54 (with hinged cover, see accessories)
	IP44 (On the rear)

### Electrical properties

Maximum charging power	22 kW
Number of phases	3
Number of power contacts	5 (L1, L2, L3, N, PE)
Rated current of power contacts	32 A
Rated voltage for power contacts	480 V AC
Number of signal contacts	2 (CP, PP)
Rated current for signal contacts	2 A
Rated voltage for signal contacts	30 V AC
Type of signal transmission	Pulse width modulation

### Mechanical properties

Insertion/withdrawal cycles	> 10000
Insertion force	< 100 N
Withdrawal force	< 100 N

### Mounting

Possible mounting positions	Rear mounting, front mounting only possible when the locking actuator is removed (see EV-T2M3SE...E00 versions)
Restrictions to mounting position	Only 0 to 90 degree frontal inclination possible, see figure
Mounting position of the locking actuator	Top center
Screw connection of a hinged cover	Only rear mounting possible
Required installation depth	< 5 mm (Rear panel mounting)
Max. wall thickness	> 57 mm (Rear panel mounting)
Mounting hole diameter	7.00 mm (ø)
Required mounting screws	M5

## Socket Outlet - EV-T2M3SE24-3AC32A-0,5M6,0E11 - 1409681

### Technical data

#### Design

Design line	Standard
Housing color	black
Customer variations	On request

#### Material

Material	Plastic
Material surface of contacts	Ag

#### Locking

Locking type	Locking in the inserted state with a locking mechanism
Locking voltage	24 V
Locking detection	Available
Mechanical emergency release	available

#### Locking actuator

Typical power supply at the motor	24 V
Possible power supply range at the motor	22 V ... 26 V
Typical motor current for locking	0.05 A
Max. reverse current of the motor	0.5 A
Max. dwell time with reverse current	1000 ms
Recommended adaptation time	600 ms
Maximum voltage for locking detection	30 V
Service life	> 10000 load cycles
Ambient temperature (operation)	-30 °C ... 50 °C
Length of cable	0.5 m

### Drawings

# Socket Outlet - EV-T2M3SE24-3AC32A-0,5M6,0E11 - 1409681

Connection diagram

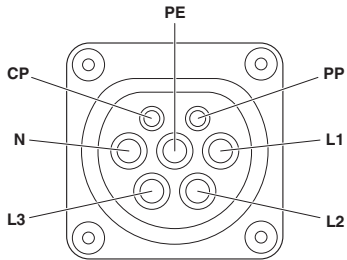

Pin assignment of Infrastructure Socket Outlet

Diagram

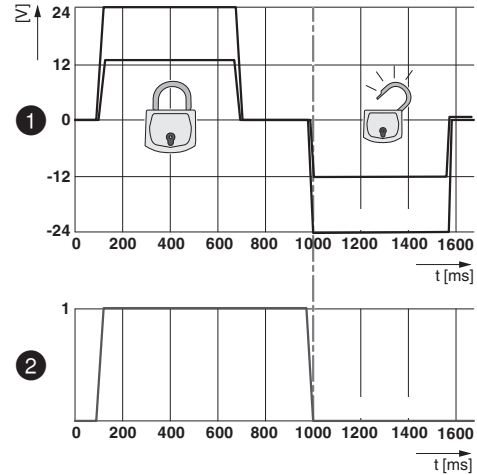

Locking states of Infrastructure Socket Outlet

Dimensional drawing

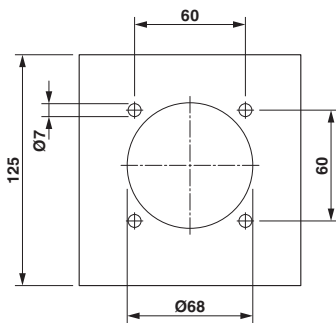

Hole image

Dimensional drawing

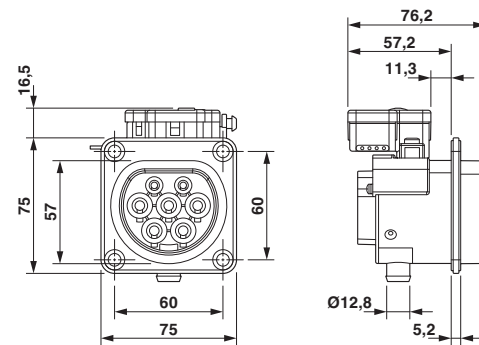

Dimensional drawing

## Socket Outlet - EV-T2M3SE24-3AC32A-0,5M6,0E11 - 1409681

Schematic diagram

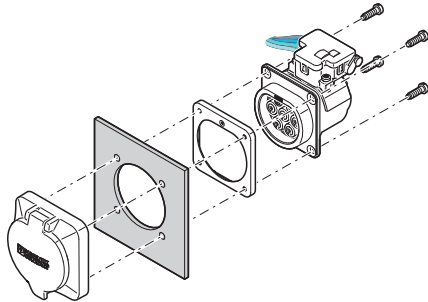

### Rear mounting with rear hinged cover screw connection

The screw connection for a hinged cover from the accessories range (EV-T2SC) only supports rear mounting. The panel thickness must not exceed 5 mm. The sealing frame that is slid on from the rear must contact the housing wall flush with the flat side and must completely surround the Infrastructure Socket Outlet.

Schematic diagram

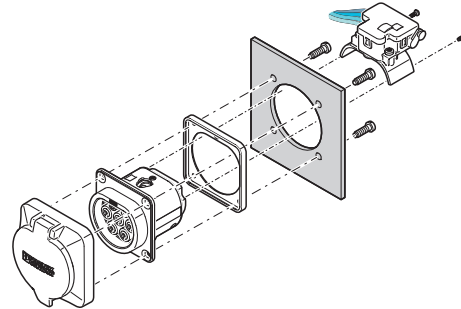

### Front mounting with rear hinged cover screw connection

Front mounting is only possible when the locking actuator is removed. We recommend using an Infrastructure Socket Outlet without pre-assembled locking actuator (EV-T2M3SE-...E0..., e.g., 1621729).

The screw connection for a hinged cover from the accessories range (EV-T2SC) only supports rear mounting. The panel thickness must not exceed 10 mm. The sealing frame that is slid on from the front must contact the housing wall flush with the flat side and must completely surround the Infrastructure Socket Outlet.

# Socket Outlet - EV-T2M3SE24-3AC32A-0,5M6,0E11 - 1409681

Schematic diagram

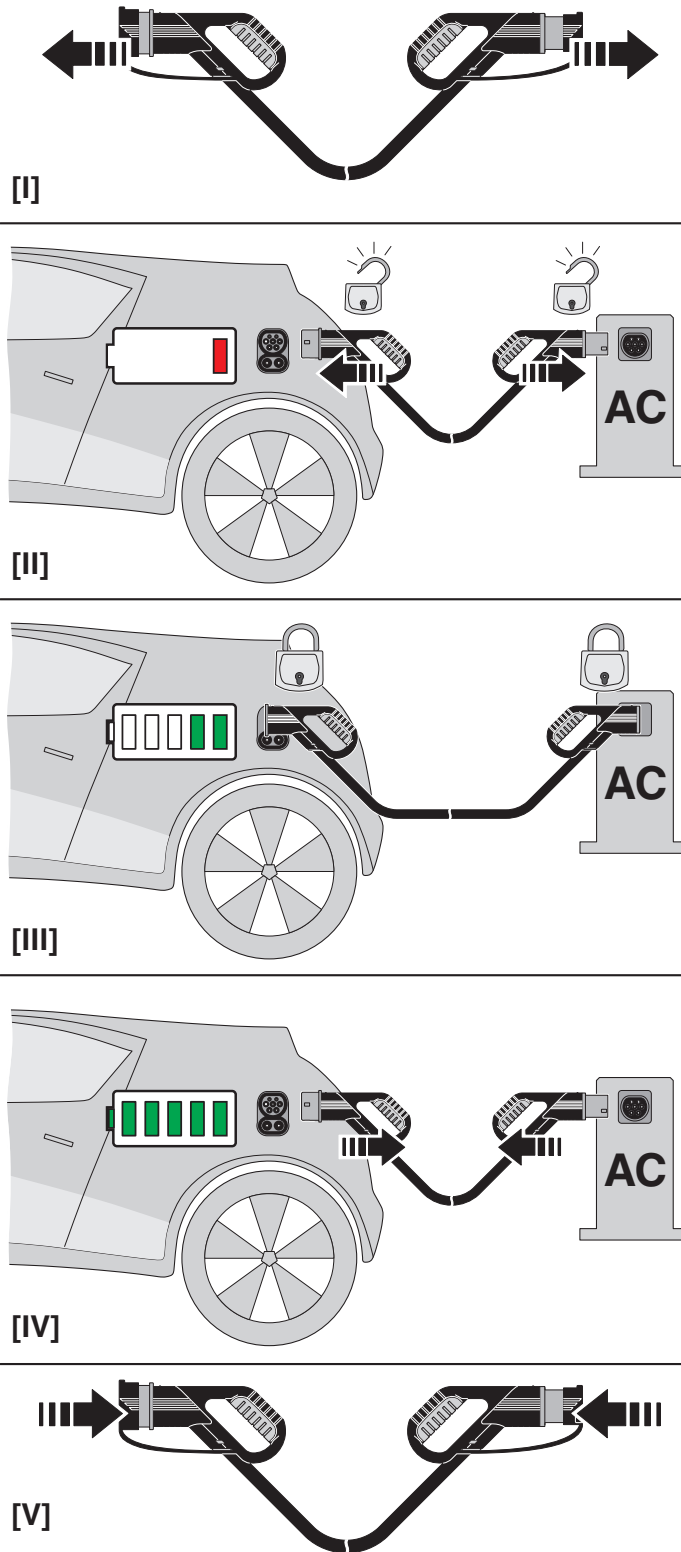

# Socket Outlet - EV-T2M3SE24-3AC32A-0,5M6,0E11 - 1409681

Schematic diagram

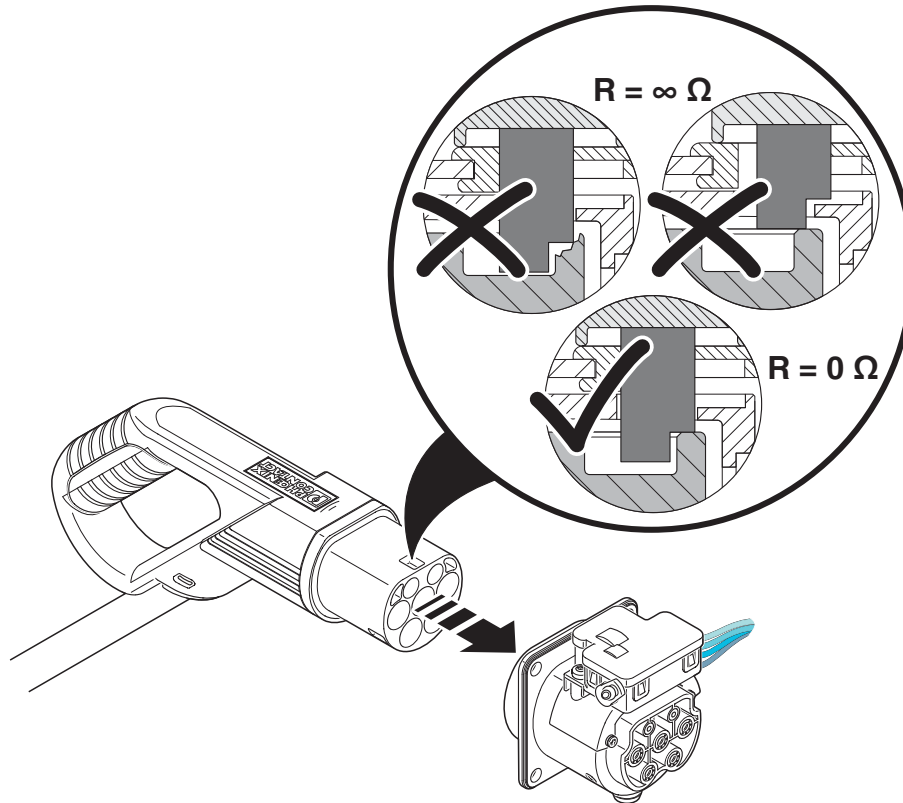

Detection of the Infrastructure Plug

Schematic diagram

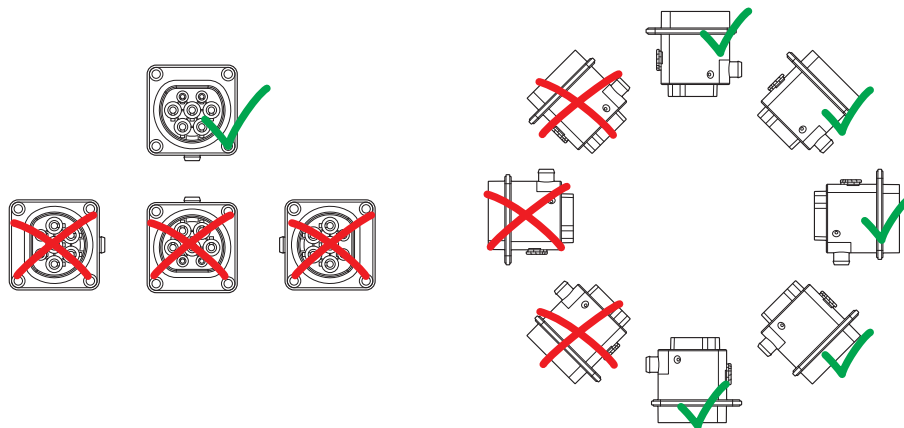

Installation positions



# Socket Outlet - EV-T2M3SE24-3AC32A-0,5M6,0E11 - 1409681

## Classifications

### eCl@ss

eCl@ss 4.0	272607xx
eCl@ss 4.1	27260701
eCl@ss 5.0	27260701
eCl@ss 5.1	27260701
eCl@ss 6.0	27279220
eCl@ss 7.0	27440103
eCl@ss 8.0	27440590
eCl@ss 9.0	27144706

### ETIM

ETIM 4.0	EC002061
ETIM 5.0	EC002061

### UNSPSC

UNSPSC 6.01	30211923
UNSPSC 7.0901	39121522
UNSPSC 11	39121522
UNSPSC 12.01	39121522
UNSPSC 13.2	39121522

## Approvals

### Approvals

---

Approvals

VDE Zeichengenehmigung

---

Ex Approvals

---

Approvals submitted

---

Approval details

# Socket Outlet - EV-T2M3SE24-3AC32A-0,5M6,0E11 - 1409681

## Approvals

VDE Zeichengenehmigung	
Nominal current I <sub>N</sub>	32 A
Nominal voltage U <sub>N</sub>	480 V

## Accessories

### Accessories

#### Panel mounting frame

Panel mounting frames - EV-T2SF - 1405218



Panel mounting frame for Infrastructure Socket Outlet, Type 2, IEC 62196-2, Thread: M5

---

### Protective cover

Protective covers - EV-T2SC - 1405217



Self-closing hinged cover for Infrastructure Socket Outlet, Type 2, IEC 62196-2, Thread: M5

---

Protective covers - EV-GBSCO - 1623415



Self-opening hinged cover for Infrastructure Socket Outlet, GB/T, Type 2, GB part 2, IEC 62196-2, Thread: M5

## Socket Outlet - EV-T2M3SE24-3AC32A-0,5M6,0E11 - 1409681

### Accessories

Protective covers - EV-GBSC - 1623416



Self-closing hinged cover for Infrastructure Socket Outlet, GB/T, Type 2, GB part 2, IEC 62196-2, Thread: M5

---

Protective covers - EV-GBSC-D6,5MM - 1623888



Self-closing hinged cover for Infrastructure Socket Outlet, GB/T, Type 2, GB part 2, IEC 62196-2, Thread: M5

---

### Safety locking

Locking - EV-T2M3S-E-LOCK12V - 1624129



Locking actuator with 12 V power supply for Infrastructure Socket Outlets and Vehicle Inlets, IEC 61851-1, 12 V Locking actuator

---

Locking - EV-T2M3S-E-LOCK24V - 1622317



Locking actuator with 24 V power supply for Infrastructure Socket Outlets and Vehicle Inlets, IEC 61851-1, 24 V Locking actuator

---

### Seal

Seal - EV-T2M3S-DRAINAGE-GASKET - 1621668

Seal for discharge nozzle below the Infrastructure Socket Outlet if there is no drainage tube , Type 2, IEC 62196-2

---

Seal - EV-T2M3S-E-LOCK-GASKET - 1621465

## Socket Outlet - EV-T2M3SE24-3AC32A-0,5M6,0E11 - 1409681

### Accessories

Seal for the mounting surface of the locking actuator above the Infrastructure Socket Outlet when there is no locking actuator present, Type 2, IEC 62196-2

---

---