



Chipsmall Limited consists of a professional team with an average of over 10 year of expertise in the distribution of electronic components. Based in Hongkong, we have already established firm and mutual-benefit business relationships with customers from,Europe,America and south Asia,supplying obsolete and hard-to-find components to meet their specific needs.

With the principle of "Quality Parts,Customers Priority,Honest Operation,and Considerate Service",our business mainly focus on the distribution of electronic components. Line cards we deal with include Microchip,ALPS,ROHM,Xilinx,Pulse,ON,Everlight and Freescale. Main products comprise IC,Modules,Potentiometer,IC Socket,Relay,Connector.Our parts cover such applications as commercial,industrial, and automotives areas.

We are looking forward to setting up business relationship with you and hope to provide you with the best service and solution. Let us make a better world for our industry!



Contact us

Tel: +86-755-8981 8866 Fax: +86-755-8427 6832

Email & Skype: info@chipsmall.com Web: www.chipsmall.com

Address: A1208, Overseas Decoration Building, #122 Zhenhua RD., Futian, Shenzhen, China



PART NUMBER	ITEM ① BODY	ITEM ② CONTACT	ITEM ③ INSULATOR	ITEM ④ CRIMP SLEEVE	ITEM ⑤ LOCK WASHER	ITEM ⑥ NUT	ITEM ⑦ HEAT SHRINK
141-0303-411	STAINLESS STEEL GOLD PL .00001 MIN OVER NICKEL PL .00005 MIN OVER	BERYLLIUM COPPER GOLD PL .00005 MIN OVER NICKEL PL .00005 MIN OVER COPPER PL .00005 MIN	TEFLON	COPPER GOLD PL .00001 MIN OVER NICKEL PL .00005 MIN OVER COPPER PL .00005 MIN	STAINLESS STEEL GOLD PL .00001 MIN OVER NICKEL PL .00005 MIN OVER	STAINLESS STEEL GOLD PL .00001 MIN OVER NICKEL PL .00005 MIN OVER	POLYOLEFIN COLOR: BLACK
141-0303-412	STAINLESS STEEL PASSIVATED	BERYLLIUM COPPER GOLD PL .00005 MIN OVER NICKEL PL .00005 MIN OVER COPPER PL .00005 MIN	TEFLON	COPPER NICKEL PL .0001 MIN OVER COPPER PL .00005 MIN	STAINLESS STEEL PASSIVATED	STAINLESS STEEL PASSIVATED	POLYOLEFIN COLOR: BLACK

DRAWING NO.
C - 141-0303-411/420

REVISIONS	
0	REVISIONS

ENGINEERING RELEASE

REV	DATE	BY	CHKD	APP'D	DESCRIPTION
1	8-10-92	RH	TJB	PAH	8-18-92 ECO 41154
2	10-5-92	RH	TJB	PAH	10-29-92 ECO 41306

ADDED: ITEM 7 HEAT SHRINK

VERSION UPDATE

* REVISION NUMBER FOLLOWED BY AN ALPHA *
* CHARACTER INDICATES DRAWING CLARIFI-
* CATION OR PART NUMBER ADDITION ONLY. *

REV	DATE	BY	CHKD	APP'D	DESCRIPTION
2a	1-31-95	RH	STW	TJB	ECN 43182

GRAPHICS & VERSION UPDATE

REV	DATE	BY	CHKD	APP'D	DESCRIPTION
3	12-16-05	PA	STW	PDW	5-12-06 ECN 50082

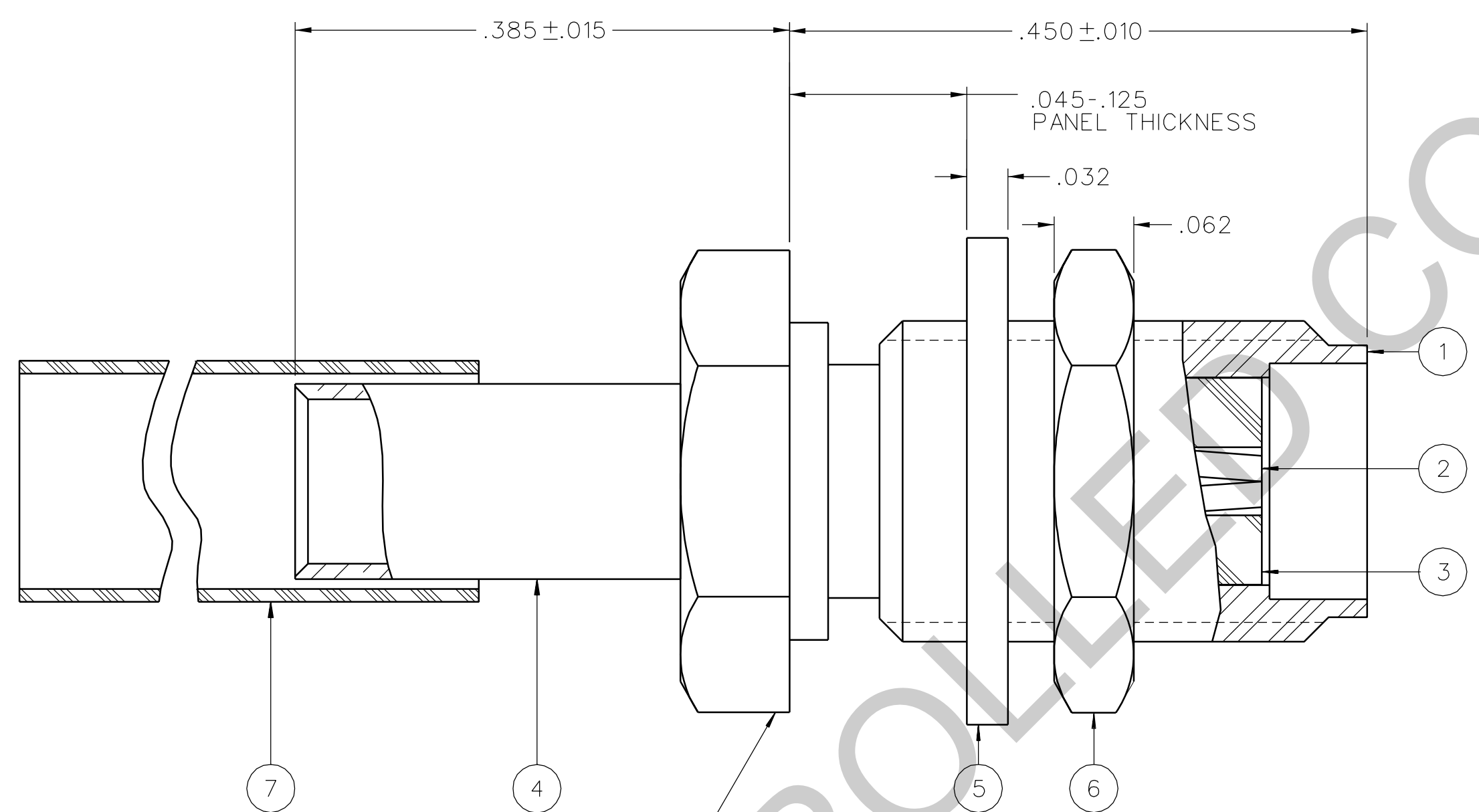

NOTES:

1. SPECIFICATIONS:
- IMPEDANCE: 50 OHMS
 FREQUENCY RANGE: 0-12.4 GHz
 VSWR: 1.15+.02 F MAX (F IN GHz)
 WORKING VOLTAGE: 250 VRMS MAX AT SEA LEVEL
 DIELECTRIC WITHSTANDING VOLTAGE: 750 VRMS MIN AT SEA LEVEL
 INSULATION RESISTANCE: 5000 MEGOHM MIN
 CONTACT RESISTANCE:
 CENTER CONTACT - INITIAL 3.0 MILLIOHM MAX, AFTER ENVIRONMENTAL 4.0 MILLIOHM MAX
 OUTER CONDUCTOR - INITIAL 2.0 MILLIOHM MAX AFTER ENVIRONMENTAL NOT APPLICABLE
 BODY TO CABLE - 0.5 MILLIOHM MAX (GOLD PLATED) 5.0 MILLIOHM MAX (PASSIVATED)
 CORONA LEVEL: 190 VOLTS MIN AT 70,000 FEET
 INSERTION LOSS: .06/F dB MAX (F IN GHz) AT 6 GHz
 RF LEAKAGE: -60 DB MIN AT 2.5 GHz
 RF HIGH POTENTIAL WITHSTANDING VOLTAGE: 500 VRMS MIN AT 4 AND 7 MHz
- MECHANICAL:
- ENGAGE/DISENGAGE TORQUE: 2 IN-LBS MAX
 MATING TORQUE: 7-10 IN-LBS
 COUPLING PROOF TORQUE: NOT APPLICABLE
 COUPLING NUT RETENTION: NOT APPLICABLE
 CONTACT RETENTION: 6 LBS MIN
 CABLE ACCEPTABILITY: RG 188/U, RG 316/U, RG 161/U, RG 174/U
 CABLE HEX CRIMP SIZE: .128
 CONTACT CRIMP TOOL: MIL M22520/1-01
 CABLE RETENTION: 20 LBS MIN AXIAL FORCE
 DURABILITY: 500 CYCLES MIN
- ENVIRONMENTAL:
- (MEETS OR EXCEEDS THE APPLICABLE PARAGRAPH OF MIL-PRF-39012)
 THERMAL SHOCK: MIL-STD-202, METHOD 107, CONDITION B, EXCEPT 85°C HIGH TEMP
 OPERATING TEMPERATURE: -65°C TO 165°C
 CORROSION: MIL-STD-202, METHOD 101, CONDITION B
 SHOCK: MIL-STD-202, METHOD 213, CONDITION I
 VIBRATION: MIL-STD-202, METHOD 204, CONDITION D
 MOISTURE RESISTANCE: MIL-STD-202, METHOD 106

2X HEX .312

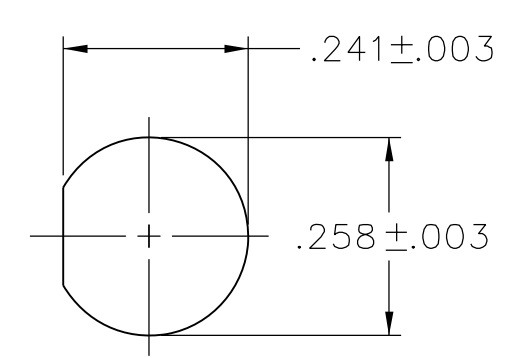

MOUNTING HOLE
4:1

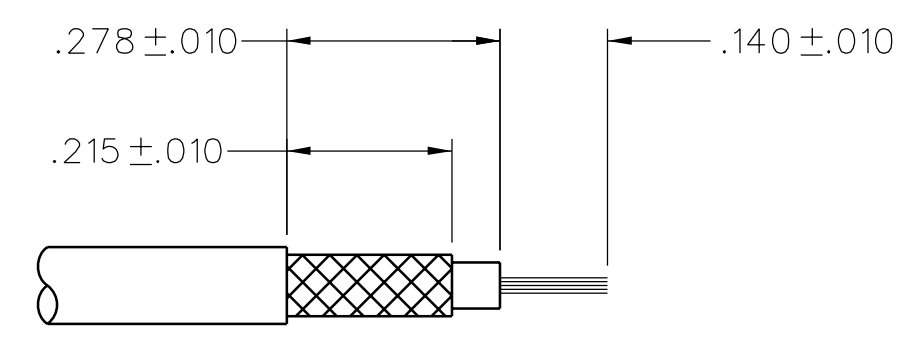

CABLE STRIP DIMENSIONS
4:1

CUSTOMER DRAWING

THIS DRAWING TO BE INTERPRETED PER ASME Y 14.5M - 1994

"μSTATION"

COMPANY CONFIDENTIAL

TOLERANCE UNLESS OTHERWISE SPECIFIED		DRAWN BY	DATE
DECIMALS	mm	TAK	7-1-92
.XX	_____	CHECKED BY	DATE
.XXX ±.003	_____	APPROVED BY	DATE
MATL	_____	RJB/TAK	8-17-92
FINISH	_____	RELEASE DATE	8-18-92
U/M	INCH	SCALE	10:1

cinch Connectivity Solutions
P.O. Box 1732
Waseca, MN 56093
1-800-247-8256

TITLE
JACK ASSEMBLY,
STRAIGHT CABLED BULKHEAD
SMA, RG 316

SHEET 2 OF 2
DRAWING NO.
C - 141-0303-411/420