



Chipsmall Limited consists of a professional team with an average of over 10 year of expertise in the distribution of electronic components. Based in Hongkong, we have already established firm and mutual-benefit business relationships with customers from,Europe,America and south Asia,supplying obsolete and hard-to-find components to meet their specific needs.

With the principle of “Quality Parts,Customers Priority,Honest Operation,and Considerate Service”,our business mainly focus on the distribution of electronic components. Line cards we deal with include Microchip,ALPS,ROHM,Xilinx,Pulse,ON,Everlight and Freescale. Main products comprise IC,Modules,Potentiometer,IC Socket,Relay,Connector.Our parts cover such applications as commercial,industrial, and automotives areas.

We are looking forward to setting up business relationship with you and hope to provide you with the best service and solution. Let us make a better world for our industry!



## Contact us

Tel: +86-755-8981 8866 Fax: +86-755-8427 6832

Email & Skype: info@chipsmall.com Web: www.chipsmall.com

Address: A1208, Overseas Decoration Building, #122 Zhenhua RD., Futian, Shenzhen, China



## Cable gland - G-INSEC-M50-L68N-NCRS-S - 1411193

Please be informed that the data shown in this PDF Document is generated from our Online Catalog. Please find the complete data in the user's documentation. Our General Terms of Use for Downloads are valid (<http://phoenixcontact.com/download>)



Cable gland, Cable gland material: Brass, nickel-plated, External cable diameter 24 mm ... 35 mm, Shielding: yes, Connecting thread: M50, Color: silver



### Key Commercial Data

Packing unit	1 pc
Custom tariff number	74199990
Country of origin	Germany

### Technical data

#### Dimensions

Length	49 mm
Wrench size, union nut	55 mm
Wrench size, support	55 mm
Hexagon angular dimension GRP	60 mm
Length of the connecting thread	9 mm
Feed-through hole diameter	50.1 mm ... 50.3 mm
External cable diameter	24 mm ... 35 mm

#### Ambient conditions

Degree of protection	IP68
Ambient temperature (operation)	-20 °C ... 100 °C (dynamic)

#### General

No. of conductors	1
Cable gland material	Brass, nickel-plated
Seal material	Neoprene

# Cable gland - G-INSEC-M50-L68N-NCRS-S - 1411193

## Technical data

### General

Cable seal material	Neoprene
O-ring material	NBR
Shielded	yes
Thread type on connection side	M50
Color	silver

### Standards and Regulations

Connection in acc. with standard	CUL
----------------------------------	-----

## Classifications

### eCl@ss

eCl@ss 5.1	27149109
eCl@ss 6.0	27149109
eCl@ss 8.0	27149109

### ETIM

ETIM 4.0	EC000441
ETIM 5.0	EC000441

## Approvals

### Approvals

---

#### Approvals

UL Listed / UL Recognized / cUL Listed / cUL Recognized / cULus Recognized / cULus Listed

---

#### Ex Approvals

---

#### Approvals submitted

---

### Approval details

UL Listed 
---

# Cable gland - G-INSEC-M50-L68N-NCRS-S - 1411193

## Approvals

UL Recognized

cUL Listed

cUL Recognized

cULus Recognized

cULus Listed

## Drawings

Dimensional drawing

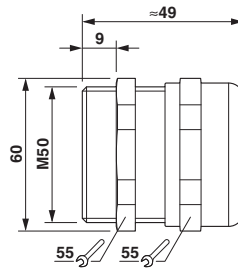

Dimensional drawing

## Cable gland - G-INSEC-M50-L68N-NCRS-S - 1411193

Functional drawing

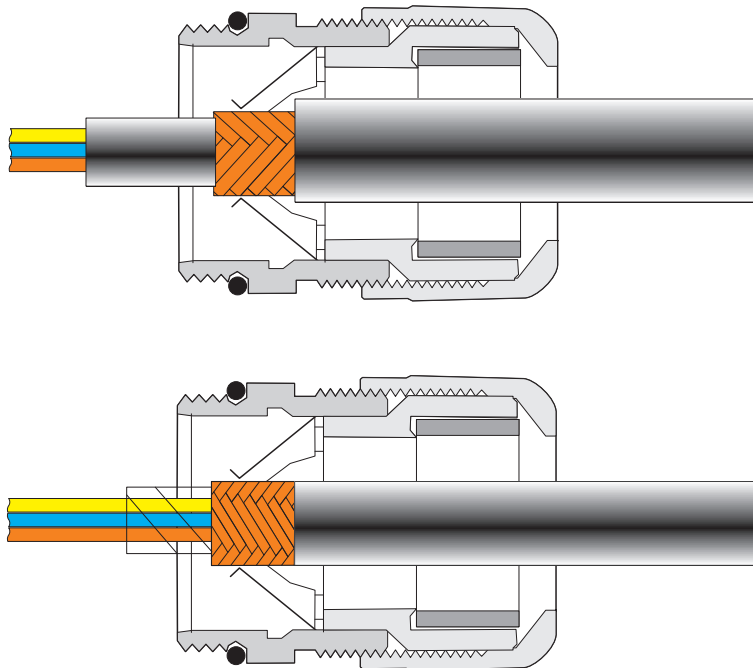

### Assembly instructions:

#### Method 1

Slit the outer sheath after approximately 15 mm, but do not remove it. Guide the cable through the screw connection and then remove the outer sheath. Now withdraw the cable until a connection is established between the conductor shield and the contact spring.

#### Method 2

Push the braided shield back approximately 15 - 20 mm over the outer sheath. Insert the cable into the screw connection until a connection is established between the conductor shield and the contact spring.

#### Method 3

Uncover about 10 mm of the braided shield and guide the cable through the screw connection until a connection is established between the conductor shield and the contact spring.