



Chipsmall Limited consists of a professional team with an average of over 10 year of expertise in the distribution of electronic components. Based in Hongkong, we have already established firm and mutual-benefit business relationships with customers from,Europe,America and south Asia,supplying obsolete and hard-to-find components to meet their specific needs.

With the principle of “Quality Parts,Customers Priority,Honest Operation,and Considerate Service”,our business mainly focus on the distribution of electronic components. Line cards we deal with include Microchip,ALPS,ROHM,Xilinx,Pulse,ON,Everlight and Freescale. Main products comprise IC,Modules,Potentiometer,IC Socket,Relay,Connector.Our parts cover such applications as commercial,industrial, and automotives areas.

We are looking forward to setting up business relationship with you and hope to provide you with the best service and solution. Let us make a better world for our industry!



## Contact us

Tel: +86-755-8981 8866 Fax: +86-755-8427 6832

Email & Skype: info@chipsmall.com Web: www.chipsmall.com

Address: A1208, Overseas Decoration Building, #122 Zhenhua RD., Futian, Shenzhen, China



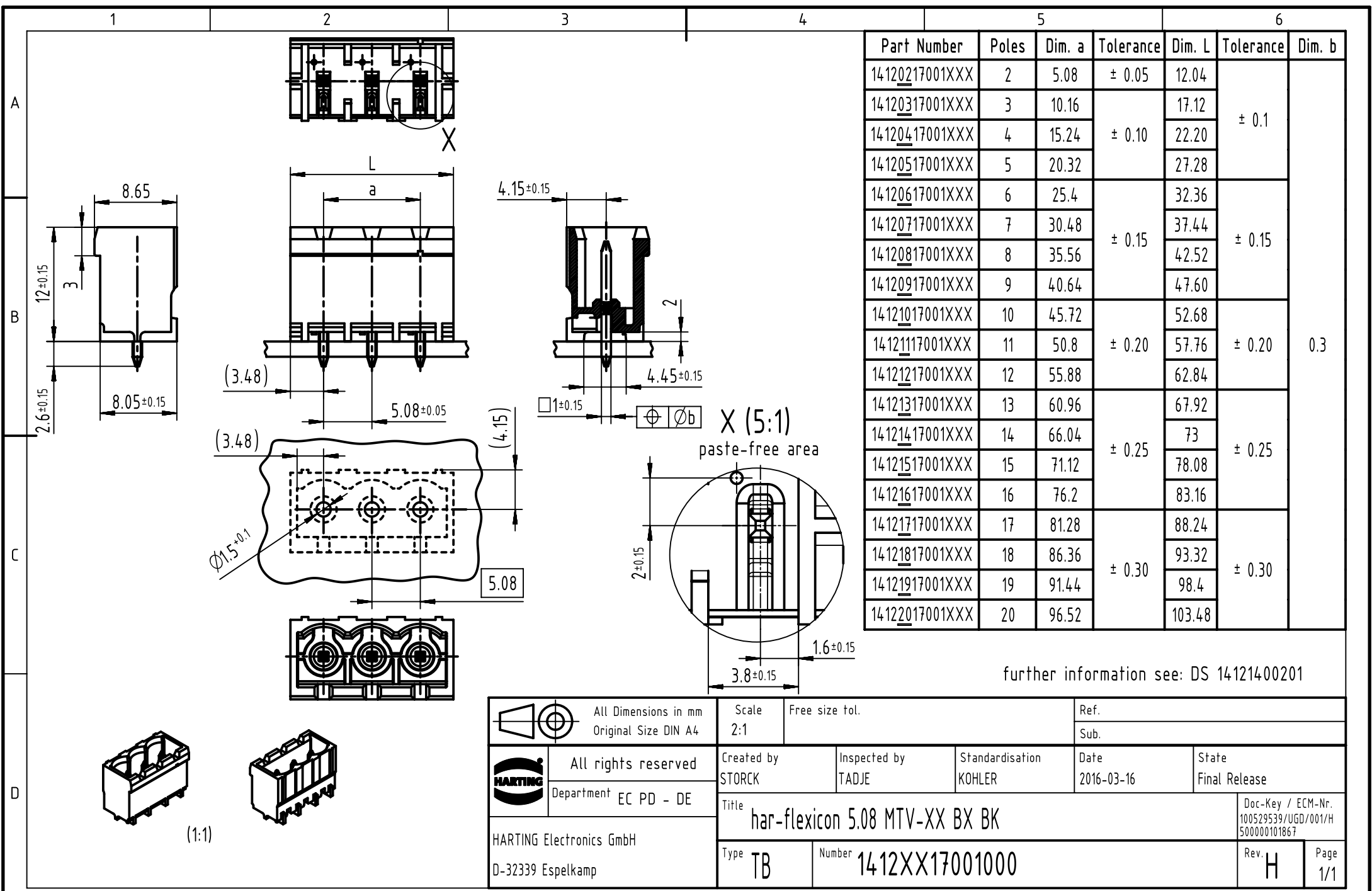

Part Number	Poles	Dim. a	Tolerance	Dim. L	Tolerance	Dim. b
14120217001XXX	2	5.08	± 0.05	12.04	± 0.1	0.3
14120317001XXX	3	10.16	± 0.10	17.12		
14120417001XXX	4	15.24		22.20		
14120517001XXX	5	20.32	± 0.15	27.28	± 0.15	0.3
14120617001XXX	6	25.4		32.36		
14120717001XXX	7	30.48		37.44		
14120817001XXX	8	35.56	± 0.20	42.52	± 0.20	0.3
14120917001XXX	9	40.64		47.60		
14121017001XXX	10	45.72	± 0.25	52.68	± 0.25	0.3
14121117001XXX	11	50.8		57.76		
14121217001XXX	12	55.88		62.84		
14121317001XXX	13	60.96	± 0.30	67.92	± 0.30	0.3
14121417001XXX	14	66.04		73		
14121517001XXX	15	71.12		78.08		
14121617001XXX	16	76.2	± 0.30	83.16	± 0.30	0.3
14121717001XXX	17	81.28		88.24		
14121817001XXX	18	86.36	± 0.30	93.32	± 0.30	0.3
14121917001XXX	19	91.44		98.4		
14122017001XXX	20	96.52		103.48		

further information see: DS 14121400201

	All Dimensions in mm Original Size DIN A4		Scale 2:1	Free size tol.		Ref.	
	All rights reserved Department EC PD - DE		Created by STORCK	Inspected by TADJE	Standardisation KOHLER	Date 2016-03-16	State Final Release
HARTING Electronics GmbH D-32339 Espelkamp		Title har-flexion 5.08 MTV-XX BX BK				Doc-Key / ECM-Nr. 100529539/UGD/001/H 500000101867	
		Type TB	Number 1412XX17001000			Rev. H	Page 1/1