



Chipsmall Limited consists of a professional team with an average of over 10 year of expertise in the distribution of electronic components. Based in Hongkong, we have already established firm and mutual-benefit business relationships with customers from,Europe,America and south Asia,supplying obsolete and hard-to-find components to meet their specific needs.

With the principle of “Quality Parts,Customers Priority,Honest Operation,and Considerate Service”,our business mainly focus on the distribution of electronic components. Line cards we deal with include Microchip,ALPS,ROHM,Xilinx,Pulse,ON,Everlight and Freescale. Main products comprise IC,Modules,Potentiometer,IC Socket,Relay,Connector.Our parts cover such applications as commercial,industrial, and automotives areas.

We are looking forward to setting up business relationship with you and hope to provide you with the best service and solution. Let us make a better world for our industry!



## Contact us

Tel: +86-755-8981 8866 Fax: +86-755-8427 6832

Email & Skype: info@chipsmall.com Web: www.chipsmall.com

Address: A1208, Overseas Decoration Building, #122 Zhenhua RD., Futian, Shenzhen, China



THIS DRAWING IS UNPUBLISHED.  
 VERTRAULICHE UNVERÖFFENTLICHTE ZEICHNUNG  
 RELEASED FOR PUBLICATION  
 FREI FUER VERÖFFENTLICHUNG  
 2007  
 MATED WITH:  
 PASSEND ZU:  
 © COPYRIGHT 2007 BY TYCO ELECTRONICS CORPORATION. ALL RIGHTS RESERVED.  
 ALLE RECHTE VORBEHALTEN

LOC	DIST	REVISIONS					
A1	-	P	LTR	DESCRIPTION	DATE	DWN	APVD
PROJEKT NR.: EGATN02178		A1		NEW DRAWING	19JUL2007	PS	-
		A2		1418776-2 IN TABLE ADDED	04SEP2008	Zayc	-

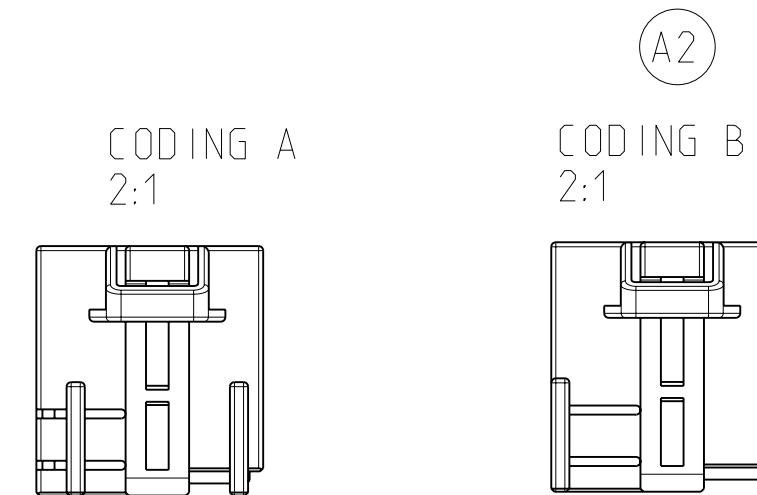
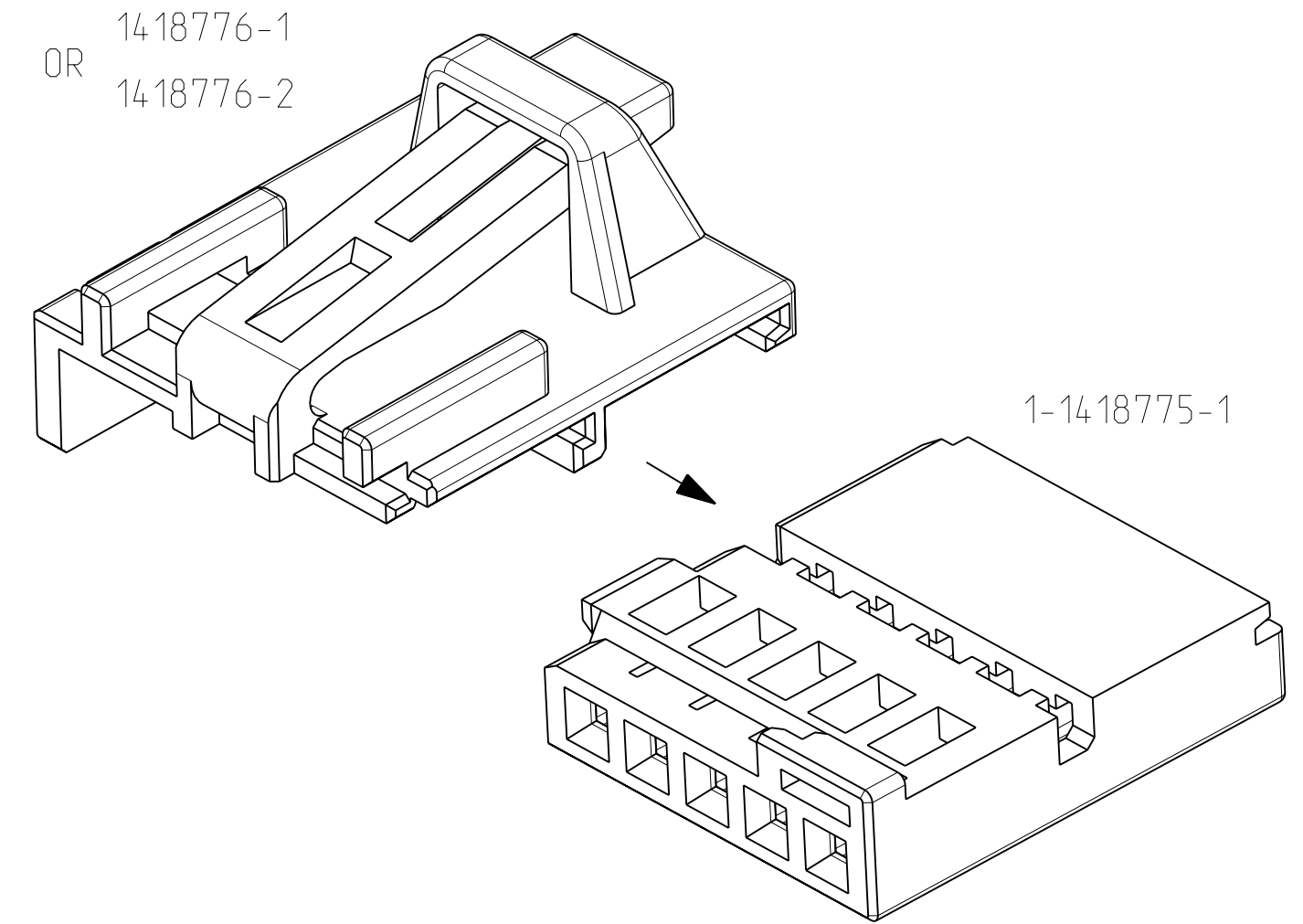
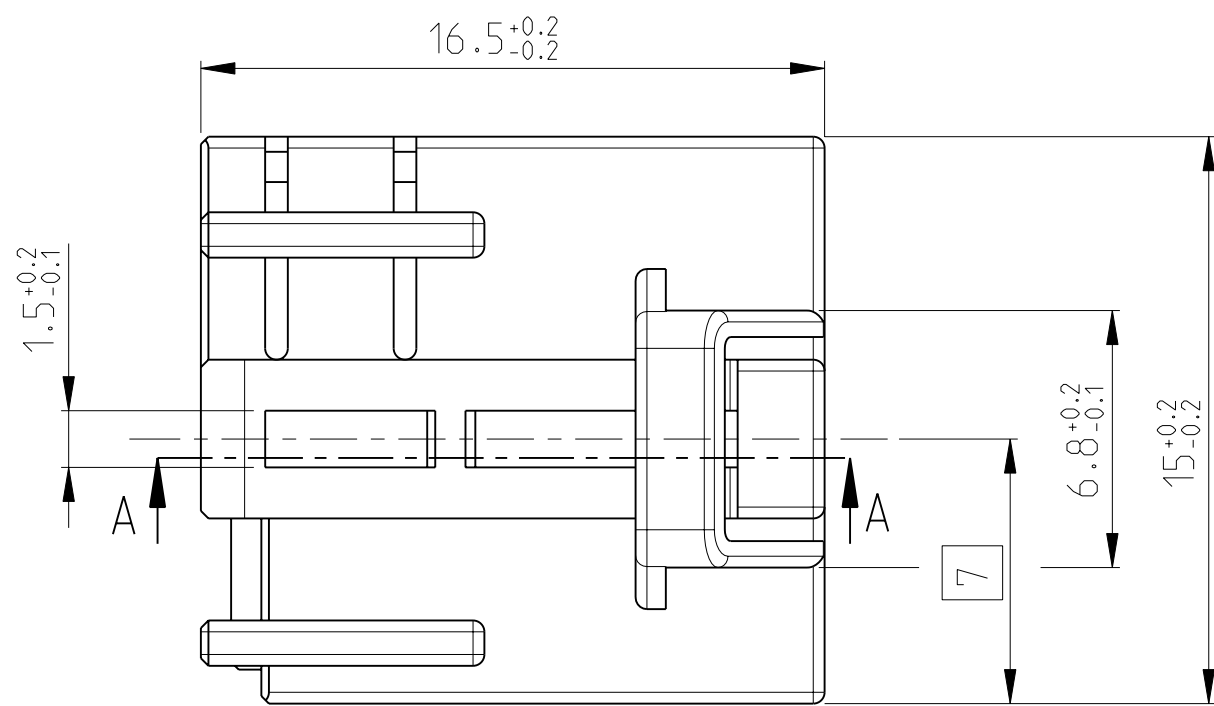
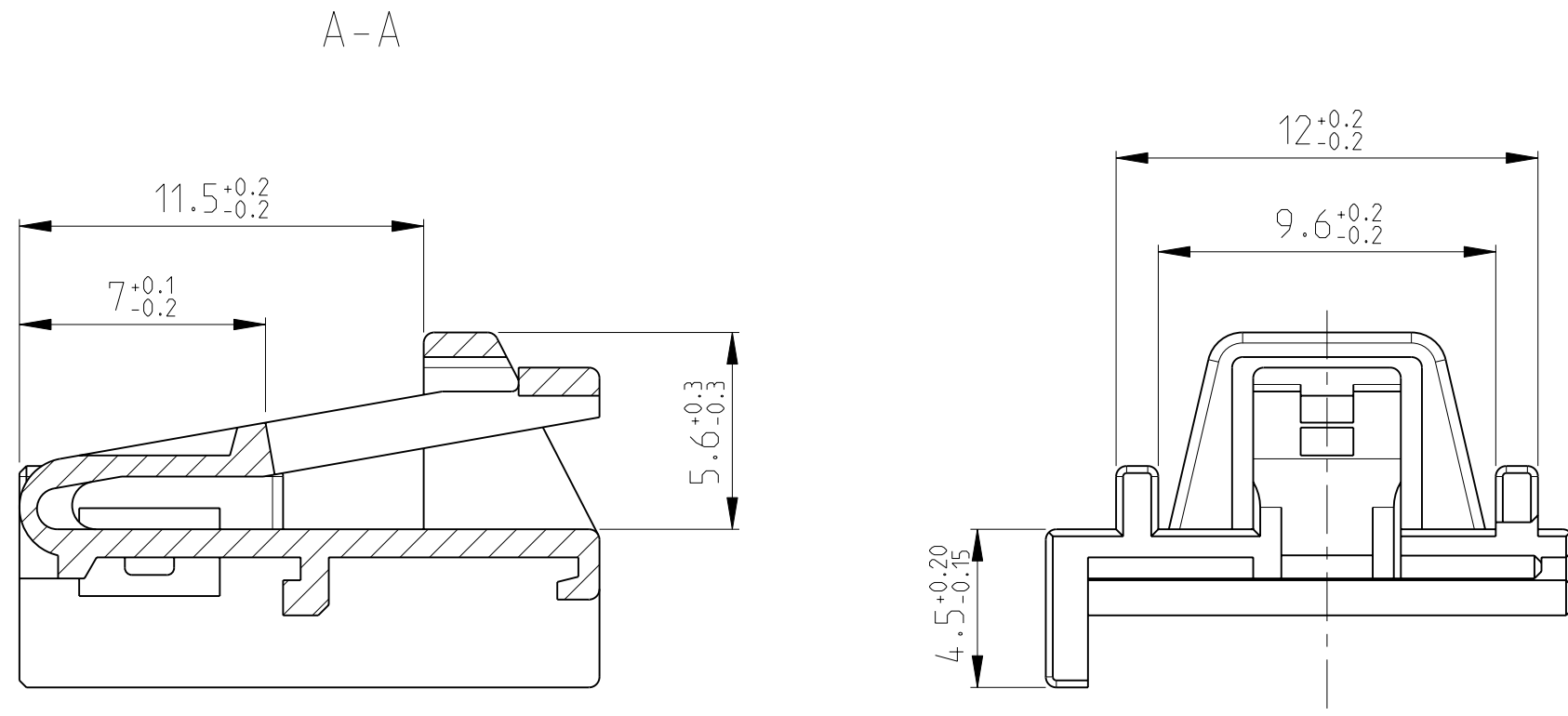

Notes

- 1 SUITABLE PIN HOUSING SEE DRAWING 1418778
- 2 SUITABLE CONTACTS: 1355717 , 9289999, 963715

Bemerkungen

- 1 Passendes Stiftgehäuse: siehe Zeichnung 1418778
- 2 Passende Kontakte: 1355717 , 9289999, 963715

PART-NO. Bestell-Nr.	REV.	COD.	MATERIAL	COLOUR Farbe	RAL	USED WITH benutzt mit
1418776-2	A	B	PBT-GF10	BROWN / braun	1011	1-1418775-1
1418776-1	A	A	PBT-GF10	BLACK / schwarz	9011	1-1418775-1

THIS DRAWING IS A CONTROLLED DOCUMENT FOR TYCO ELECTRONICS CORPORATION IT IS SUBJECT TO CHANGE AND THE CONTROLLING ENGINEERING ORGANIZATION SHOULD BE CONTACTED FOR THE LATEST REVISION. DIESES ZEICHNUNGSDOKUMENT WIRD DURCH AMP INCORPORATED KONTROLLIERT. ÄNDERUNGEN, DIE DEM TECHNISCHEN FORTSCHRITT DIENEN, SIND VORBEHALTEN. DEN JEWELIGEN LETZTGÜLTIGEN ÄNDERUNGSSTAND ERFAHREN SIE AUF ANFRAGE.		DWN P. Spohr 19JUL2007	tyco Electronics tyco Electronics AMP GmbH 64625 Bensheim (Germany)	
DIMENSIONS: MASSE IN HEITEN: [mm]	TOLERANCES UNLESS OTHERWISE SPECIFIED: ALLGEMEINTOLERANZEN	CHK B. Leonhardt	NAME 5 POSN. MQS HOUSING, RETAINER 5 pol. MQS Gehäuse, Verriegelung	
MATERIAL SEE TABLE	FINISH/ÖBERFLÄCHE/FARBE SEE TABLE	PRODUCT SPEC DIN 16901-14.0 108-18924	SIZE A2	RESTRICTED TO NUR FUER -
		APPLICATION SPEC VERARBEITUNGSSPEZ. 114-18630	CAGE CODE 00779	DRAWING NO. ZEICHNUNGS-NR. 1418776
CUSTOMER DRAWING		/KUNDENZEICHNUNG		SCALE MASSSTAB 5:1
		SHEET BLATT 1 OF 1		REV A2