

Chipsmall Limited consists of a professional team with an average of over 10 year of expertise in the distribution of electronic components. Based in Hongkong, we have already established firm and mutual-benefit business relationships with customers from,Europe,America and south Asia,supplying obsolete and hard-to-find components to meet their specific needs.

With the principle of “Quality Parts,Customers Priority,Honest Operation,and Considerate Service”,our business mainly focus on the distribution of electronic components. Line cards we deal with include Microchip,ALPS,ROHM,Xilinx,Pulse,ON,Everlight and Freescale. Main products comprise IC,Modules,Potentiometer,IC Socket,Relay,Connector.Our parts cover such applications as commercial,industrial, and automotives areas.

We are looking forward to setting up business relationship with you and hope to provide you with the best service and solution. Let us make a better world for our industry!



## Contact us

Tel: +86-755-8981 8866 Fax: +86-755-8427 6832

Email & Skype: info@chipsmall.com Web: www.chipsmall.com

Address: A1208, Overseas Decoration Building, #122 Zhenhua RD., Futian, Shenzhen, China

# Housing - HC-STA-D07-BWS-EL-AL - 1419249

Please be informed that the data shown in this PDF Document is generated from our Online Catalog. Please find the complete data in the user's documentation. Our General Terms of Use for Downloads are valid (<http://phoenixcontact.com/download>)



Panel mounting base D7, with single locking latch, material: Die-cast aluminum, salt water resistant, height: 25.5 mm, cable gland: none, support sleeve: no, Standard



## Key Commercial Data

Packing unit	1 STK
GTIN	
GTIN	4055626159805

## Technical data

### Dimensions

Height	25.5 mm
Width	34.2 mm
Length	24.2 mm
Length of the assembly cutout	21 mm
Width of the assembly cutout	21 mm

### Ambient conditions

Degree of protection of housing (IP)	IP66
	IP67
Ambient temperature (operation)	-40 °C ... 125 °C

### General

Note	for contact inserts HC-A03, A04, D07, D08, Q02, Q03, Q04, Q05, Q07, Q12
Size	D7
Housing type	Panel mounting base
Color	gray aluminum
Locking type	with single locking latch

# Housing - HC-STA-D07-BWS-EL-AL - 1419249

## Technical data

### General

Screw connection	none
Housing material	Die-cast aluminum, salt water resistant
Housing surface material	uncoated
Seal material	NBR
Material lock	PA

### Environmental Product Compliance

China RoHS	Environmentally Friendly Use Period = 50
	For details about hazardous substances go to tab "Downloads", Category "Manufacturer's declaration"

## Drawings

Dimensional drawing

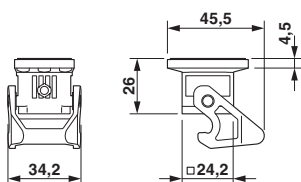

Dimensional drawing

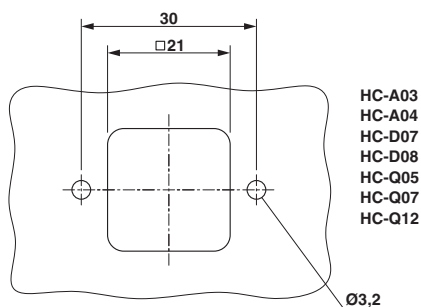

Dimensional drawing

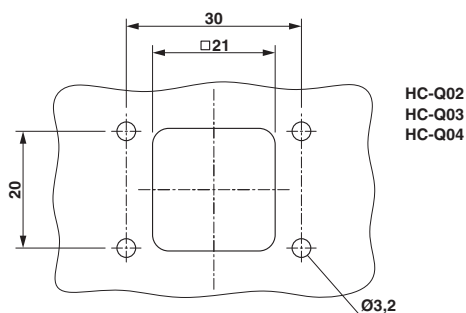

Mounting cutout

## Approvals

### Approvals

Approvals

EAC / GL

# Housing - HC-STA-D07-BWS-EL-AL - 1419249

## Approvals

Ex Approvals

---

### Approval details

EAC		RU C- DE.AI30.B.01102
-----	---	--------------------------

GL		<a href="http://exchange.dnv.com/tari/">http://exchange.dnv.com/tari/</a>	6196614 HH
----	---	---	------------

---

Phoenix Contact 2018 © - all rights reserved  
<http://www.phoenixcontact.com>

PHOENIX CONTACT GmbH & Co. KG  
Flachsmarktstr. 8  
32825 Blomberg  
Germany  
Tel. +49 5235 300  
Fax +49 5235 3 41200  
<http://www.phoenixcontact.com>