



Chipsmall Limited consists of a professional team with an average of over 10 year of expertise in the distribution of electronic components. Based in Hongkong, we have already established firm and mutual-benefit business relationships with customers from,Europe,America and south Asia,supplying obsolete and hard-to-find components to meet their specific needs.

With the principle of "Quality Parts,Customers Priority,Honest Operation,and Considerate Service",our business mainly focus on the distribution of electronic components. Line cards we deal with include Microchip,ALPS,ROHM,Xilinx,Pulse,ON,Everlight and Freescale. Main products comprise IC,Modules,Potentiometer,IC Socket,Relay,Connector.Our parts cover such applications as commercial,industrial, and automotives areas.

We are looking forward to setting up business relationship with you and hope to provide you with the best service and solution. Let us make a better world for our industry!



Contact us

Tel: +86-755-8981 8866 Fax: +86-755-8427 6832

Email & Skype: info@chipsmall.com Web: www.chipsmall.com

Address: A1208, Overseas Decoration Building, #122 Zhenhua RD., Futian, Shenzhen, China



PART NUMBER	ITEM ① BODY	ITEM ② NUT	ITEM ③ CONTACT	ITEM ④ INSULATOR	ITEM ⑤ RETENTION SPRING	ITEM ⑥ END CAP	ITEM ⑦ CLAMP CONE
142-0203-101	BRASS GOLD PL .00001 MIN OVER NICKEL PL .00005 MIN OVER COPPER PL .00005 MIN	BRASS GOLD PL .00001 MIN OVER NICKEL PL .00005 MIN OVER COPPER PL .00005 MIN	BRASS GOLD PL .00003 MIN OVER NICKEL PL .00005 MIN OVER COPPER PL .00005 MIN	TEFLON	BERYLLIUM COPPER UNPLATED	BRASS GOLD PL .00001 MIN OVER NICKEL PL .00005 MIN OVER COPPER PL .00005 MIN	BRASS GOLD PL .00001 MIN OVER NICKEL PL .00005 MIN OVER COPPER PL .00005 MIN
142-0203-106	BRASS NICKEL PL .0001 MIN OVER COPPER PL .00005 MIN	BRASS NICKEL PL .0001 MIN OVER COPPER PL .00005 MIN	BRASS GOLD PL .00003 MIN OVER NICKEL PL .00005 MIN OVER COPPER PL .00005 MIN	TEFLON	BERYLLIUM COPPER UNPLATED	BRASS NICKEL PL .0001 MIN OVER COPPER PL .00005 MIN	BRASS NICKEL PL .0001 MIN OVER COPPER PL .00005 MIN

PART NUMBER	ITEM ⑧ CLAMP NUT
142-0203-101	BRASS GOLD PL .00001 MIN OVER NICKEL PL .00005 MIN OVER COPPER PL .00005 MIN
142-0203-106	BRASS NICKEL PL .0001 MIN OVER COPPER PL .00005 MIN

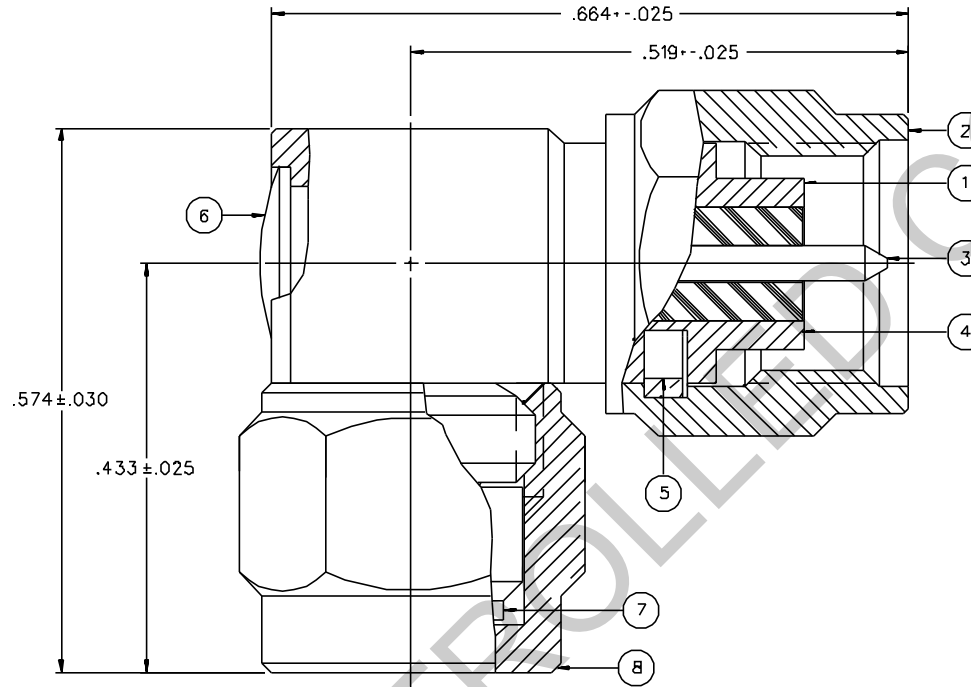

NOTES:

1. SPECIFICATIONS:

IMPEDANCE: 50 OHMS
 FREQUENCY RANGE: 0-12.4 GHz
 VSWR: 1.15-.03 F MAX (F IN GHz)
 WORKING VOLTAGE: 250 VRMS MAX AT SEA LEVEL
 DIELECTRIC WITHSTANDING VOLTAGE: 750 VRMS MIN AT SEA LEVEL
 INSULATION RESISTANCE: 5000 MEGOHM MIN
 CONTACT RESISTANCE:
 CENTER CONTACT - INITIAL 4.0 MILLIOHM MAX, AFTER ENVIRONMENTAL 6.0 MILLIOHM MAX
 OUTER CONDUCTOR - INITIAL 2.0 MILLIOHM MAX
 AFTER ENVIRONMENTAL NOT APPLICABLE
 BODY TO CABLE - 0.5 MILLIOHM MAX (GOLD PLATED), 5.0 MILLIOHM MAX (NICKEL PLATED)
 CORONA LEVEL: 190 VOLTS MIN AT 70,000 FEET
 INSERTION LOSS: .15 F (F IN GHz) AT 6 GHz
 RF LEAKAGE: -60 DB MIN AT 2.5 GHz
 RF HIGH POTENTIAL WITHSTANDING VOLTAGE: 500 VRMS AT 4 AND 7 MHZ

MECHANICAL:

ENGAGE/DISENGAGE TORQUE: 2 INCH-POUNDS MAX
 MATING TORQUE: 7-10 INCH POUNDS
 COUPLING PROOF TORQUE: 15 INCH-POUNDS MIN
 COUPLING NUT RETENTION: 6D LBS MIN
 CONTACT RETENTION: 6 LBS MIN
 CABLE ACCEPTABILITY: RG 188/U, RG 316/U, RG 161/U, RG 174/U
 CABLE HEX CRIMP SIZE: NOT APPLICABLE
 CABLE RETENTION: 20 LBS MIN AXIAL FORCE
 DURABILITY: 500 CYCLES MIN

ENVIRONMENTAL:

(MEETS OR EXCEEDS THE APPLICABLE PARAGRAPH OF MIL-C-39012)
 THERMAL SHOCK: MIL-STD-202, METHOD 107, CONDITION B
 EXCEPT -85 DEG C HIGH TEMP
 OPERATING TEMPERATURE: -65 DEG C TO 165 DEG C
 CORROSION: MIL-STD-202, METHOD 101, CONDITION B
 SHOCK: MIL-STD-202, METHOD 213, CONDITION I
 VIBRATION: MIL-STD-202, METHOD 204, CONDITION D
 MOISTURE RESISTANCE: MIL-STD-202, METHOD 106

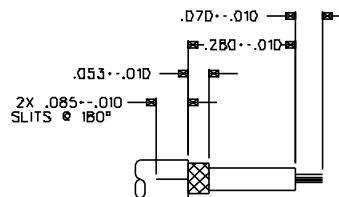

CABLE STRIP DIMENSIONS

4:1

DRAWING NO. C - 142-0203-101/110			
0 REVISIONS			
ENGINEERING RELEASE			
1	1-8-91	R H A	1-22-91 ECO 24997
CHANGED: RF LEAK 2.5 GHz WAS 2 TO 3, RF HIGH POT 4 AND 7 MHZ WAS 5 TO 7.5			
2	4-6-92	R H A	4-14-92 ECO 40918
CHANGED: CABLE STRIP DIMENSION .053 ± .010 WAS .050 ± .010			
3	12-14-93	R H A	ECO 42208

CUSTOMER DRAWING

THIS DRAWING TO BE INTERPRETED PER ANSI Y 14.5M - 1982

"μSTATION"

COMPANY CONFIDENTIAL

TOLERANCE UNLESS OTHERWISE SPECIFIED	DRAWN BY EJ	DATE 5-1-90	JOHNSON Cinch Connectivity Solutions 299 Johnson Ave. Ste. 100 Worcester, MA 01609 1-800-247-8256	
DECIMALS .XX	CHECKED BY	DATE 1-14-91	TITLE PLUG ASSEMBLY, RA CABLED, RG 316 SMA	
.XXX	APPROVED BY VET	DATE 1-14-91	CODE NO.	DRAWING NO. C - 142-0203-101/110
MATL	APPROVED BY RJB	DATE 1-14-91	SCALE 10:1	U/W INCH SHEET 2 OF 2
FINISH	RELEASE DATE	1-22-91		