



Chipsmall Limited consists of a professional team with an average of over 10 year of expertise in the distribution of electronic components. Based in Hongkong, we have already established firm and mutual-benefit business relationships with customers from,Europe,America and south Asia,supplying obsolete and hard-to-find components to meet their specific needs.

With the principle of “Quality Parts,Customers Priority,Honest Operation,and Considerate Service”,our business mainly focus on the distribution of electronic components. Line cards we deal with include Microchip,ALPS,ROHM,Xilinx,Pulse,ON,Everlight and Freescale. Main products comprise IC,Modules,Potentiometer,IC Socket,Relay,Connector.Our parts cover such applications as commercial,industrial, and automotives areas.

We are looking forward to setting up business relationship with you and hope to provide you with the best service and solution. Let us make a better world for our industry!



Contact us

Tel: +86-755-8981 8866 Fax: +86-755-8427 6832

Email & Skype: info@chipsmall.com Web: www.chipsmall.com

Address: A1208, Overseas Decoration Building, #122 Zhenhua RD., Futian, Shenzhen, China



PART NUMBER	ITEM ① BODY	ITEM ② CONTACT	ITEM ③ INSULATOR	ITEM ④ FLAT WASHER	ITEM ⑤ LOCK WASHER	ITEM ⑥ NUT	"P"	"T"
142-0701-401	BRASS GOLD PL .00001 MIN OVER NICKEL PL .00005 MIN OVER COPPER PL .00005 MIN	BERYLLIUM COPPER GOLD PL .00005 MIN OVER NICKEL PL .00005 MIN OVER COPPER PL .00005 MIN	TEFLON	NONE	BRONZE GOLD PL .00001 MIN OVER NICKEL PL .00005 MIN	BRASS GOLD PL .00001 MIN OVER NICKEL PL .00005 MIN OVER COPPER PL .00005 MIN	.109	.094
142-0701-402	BRASS GOLD PL .00001 MIN OVER NICKEL PL .00005 MIN OVER COPPER PL .00005 MIN	BERYLLIUM COPPER GOLD PL .00005 MIN OVER NICKEL PL .00005 MIN OVER COPPER PL .00005 MIN	TEFLON	NONE	BRONZE GOLD PL .00001 MIN OVER NICKEL PL .00005 MIN	BRASS GOLD PL .00001 MIN OVER NICKEL PL .00005 MIN OVER COPPER PL .00005 MIN	.109	.094
142-0701-403	BRASS GOLD PL .00001 MIN OVER NICKEL PL .00005 MIN OVER COPPER PL .00005 MIN	BERYLLIUM COPPER GOLD PL .00005 MIN OVER NICKEL PL .00005 MIN OVER COPPER PL .00005 MIN	TEFLON	NONE	NONE	NONE		
142-0701-404	BRASS GOLD PL .00001 MIN OVER NICKEL PL .00005 MIN OVER COPPER PL .00005 MIN	BERYLLIUM COPPER GOLD PL .00005 MIN OVER NICKEL PL .00005 MIN OVER COPPER PL .00005 MIN	TEFLON	BRASS GOLD PL .00001 MIN OVER NICKEL PL .00005 MIN OVER COPPER PL .00005 MIN	NONE	BRASS GOLD PL .00001 MIN OVER NICKEL PL .00005 MIN OVER COPPER PL .00005 MIN	.125	.062
142-0701-405	COPPER GOLD PL .00005 MIN OVER COPPER PL .00005 MIN	BERYLLIUM COPPER GOLD PL .00005 MIN OVER COPPER PL .00005 MIN	TEFLON	NONE	NONE	COPPER GOLD PL .00005 MIN OVER COPPER PL .00005 MIN	.125	.062
142-0701-406	BRASS NICKEL PL .0001 MIN OVER COPPER PL .00005 MIN	BERYLLIUM COPPER GOLD PL .00005 MIN OVER NICKEL PL .00005 MIN OVER COPPER PL .00005 MIN	TEFLON	NONE	BRONZE NICKEL PL .0001 MIN OVER COPPER PL .00005 MIN	BRASS NICKEL PL .0001 MIN OVER COPPER PL .00005 MIN	.109	.094
142-0701-407	BRASS NICKEL PL .0001 MIN OVER COPPER PL .00005 MIN	BERYLLIUM COPPER GOLD PL .00005 MIN OVER NICKEL PL .00005 MIN OVER COPPER PL .00005 MIN	TEFLON	BRASS NICKEL PL .0001 MIN OVER COPPER PL .00005 MIN	NONE	BRASS NICKEL PL .0001 MIN OVER COPPER PL .00005 MIN	.125	.062
142-0701-408	BRASS GOLD PL .00001 MIN OVER NICKEL PL .00005 MIN OVER COPPER PL .00005 MIN	BERYLLIUM COPPER GOLD PL .00005 MIN OVER NICKEL PL .00005 MIN OVER COPPER PL .00005 MIN	TEFLON	BRASS GOLD PL .00001 MIN OVER NICKEL PL .00005 MIN OVER COPPER PL .00005 MIN	BRONZE GOLD PL .00001 MIN OVER NICKEL PL .00005 MIN OVER COPPER PL .00005 MIN	BRASS GOLD PL .00001 MIN OVER NICKEL PL .00005 MIN OVER COPPER PL .00005 MIN	.109	.062
142-0701-409	BRASS GOLD PL .00001 MIN OVER NICKEL PL .00005 MIN OVER COPPER PL .00005 MIN	BERYLLIUM COPPER GOLD PL .00005 MIN OVER NICKEL PL .00005 MIN OVER COPPER PL .00005 MIN	TEFLON	NONE	BRONZE GOLD PL .00001 MIN OVER NICKEL PL .00005 MIN OVER COPPER PL .00005 MIN	BRASS GOLD PL .00001 MIN OVER NICKEL PL .00005 MIN OVER COPPER PL .00005 MIN	.125	.062

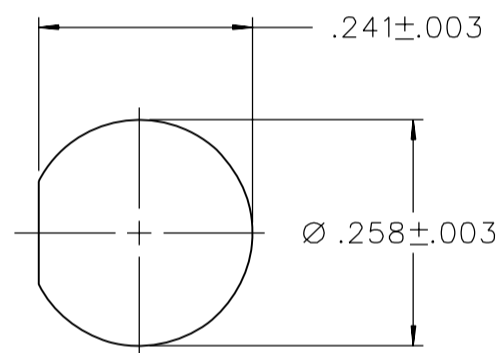

MOUNTING HOLE
4:1

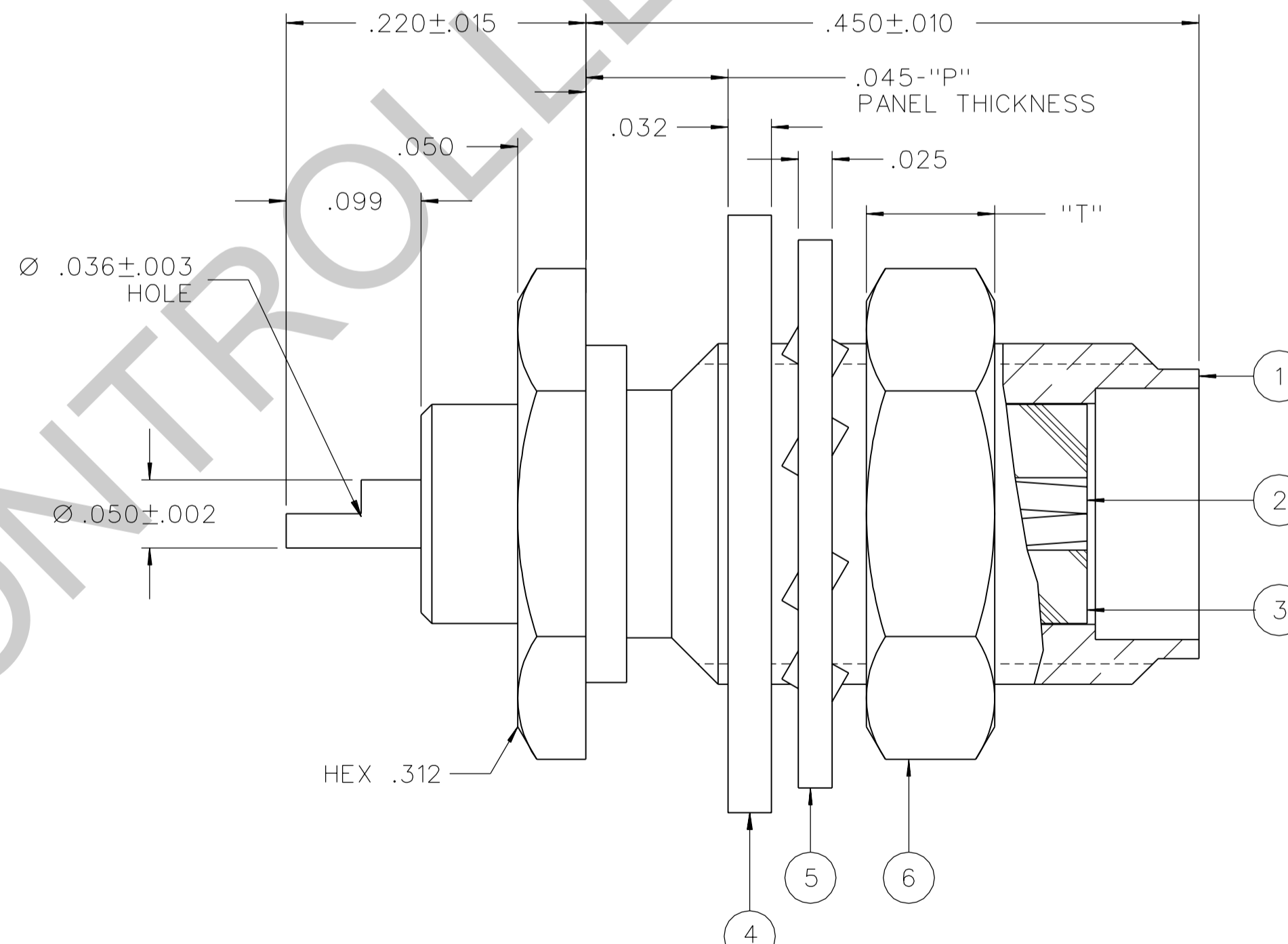

NOTES:

1. SPECIFICATIONS:

IMPEDANCE: 50 OHMS
 FREQUENCY RANGE: 0-18 GHZ
 VSWR: NOT APPLICABLE
 WORKING VOLTAGE: 335 VRMS MAX AT SEA LEVEL
 DIELECTRIC WITHSTANDING VOLTAGE: 1000 VRMS MIN AT SEA LEVEL
 INSULATION RESISTANCE: 5000 MEGOHM MIN
 CONTACT RESISTANCE:
 CENTER CONTACT - INITIAL 3.0 MILLIOHM MAX, AFTER ENVIRONMENTAL 4.0 MILLIOHM MAX
 OUTER CONDUCTOR - INITIAL 2.0 MILLIOHM MAX AFTER ENVIRONMENTAL NOT APPLICABLE
 BODY TO CABLE - NOT APPLICABLE
 CORONA LEVEL: 250 VOLTS MIN AT 70,000 FEET
 INSERTION LOSS: NOT APPLICABLE
 RF LEAKAGE: NOT APPLICABLE
 RF HIGH POTENTIAL WITHSTANDING VOLTAGE: 670 VRMS MIN AT 4 AND 7 MHZ

MECHANICAL:

ENGAGE/DISENGAGE TORQUE: 2 INCH-POUNDS MAX
 MATING TORQUE: 7-10 INCH POUNDS
 COUPLING PROOF TORQUE: NOT APPLICABLE
 COUPLING NUT RETENTION: NOT APPLICABLE
 CONTACT RETENTION: 6 LBS MIN AXIAL FORCE
 4 IN-OZ MIN RADIAL TORQUE
 CABLE ACCEPTABILITY: NOT APPLICABLE
 CABLE HEX CRIMP SIZE: NOT APPLICABLE
 CABLE RETENTION: NOT APPLICABLE
 DURABILITY: 500 CYCLES MIN

ENVIRONMENTAL:

(MEETS OR EXCEEDS THE APPLICABLE PARAGRAPH OF MIL-PRF-39012)
 THERMAL SHOCK: MIL-STD-202, METHOD 107, CONDITION B, EXCEPT 200° C HIGH TEMP
 OPERATING TEMPERATURE: -65 DEG C TO 165 DEG C
 CORROSION: MIL-STD-202, METHOD 101, CONDITION B
 SHOCK: MIL-STD-202, METHOD 213, CONDITION I
 VIBRATION: MIL-STD-202, METHOD 204, CONDITION D
 MOISTURE RESISTANCE: MIL-STD-202, METHOD 106

DRAWING NO.
C - 142-0701-401/410

0 REVISIONS

ADDED: P/N 142-0701-402

5 3-11-93 R H J B P A H 3-15-93 ECO 41618

VERSION UPDATE

5a 5-27-94 R H J B P A H 6-1-94 ECN 42531

ADDED: P/N 142-0701-403

5b 6-27-94 R H J B P A H ECN 42616

VERSION UPDATE

5c 9-23-97 R H S W T R J B A ECN 44995

ADDED: P/N 142-0701-405

5d 4-20-99 R H J B P A H ECN 46306

CHANGED: MATERIAL ITEMS 1 AND 5 P/N 142-0701-405 COPPER WAS BRASS

 * REVISION NUMBER FOLLOWED BY AN ALPHA *
 * CHARACTER INDICATES DRAWING CLARIFICATION *
 * CATION OR PART NUMBER ADDITION ONLY. *

5e 3-29-00 R H J B P A H ECN 46457

BRONZE WAS BRASS (2X)
 LOCK WAS FLAT "P" WAS .125
 .032 WAS .018, "T" WAS .062

ADDED: LOCKWASHER, .025
 ADDED: P/N 142-0701-404
 ADDED: P/N 142-0701-407
 ADDED: P/N 142-0701-408

6 5-30-01 R H J B P A H 1-24-06 ECN 47866

DELETED: FLAT WASHER FROM 142-0701-405

7 1-24-06 P A T J B J S J C N 1-31-06 ECN 50219

ADDED P/N: 142-0701-409

 * REVISION NUMBER FOLLOWED BY AN ALPHA *
 * CHARACTER INDICATES DRAWING CLARIFICATION *
 * CATION OR PART NUMBER ADDITION ONLY. *

7a 8-17-07 P A T J B J S J C N 8-21-07 ECN 51184

CUSTOMER DRAWING

THIS DRAWING TO BE INTERPRETED PER ASME Y 14.5M - 1994

"μSTATION"

COMPANY CONFIDENTIAL

TOLERANCE UNLESS OTHERWISE SPECIFIED	DRAWN BY EJ	DATE 5-1-90
DECIMALS _____ mm _____	CHECKED BY OMI	DATE 5-10-90
.XX _____	APPROVED BY RJB	DATE 5-10-90
.XXX _____	RELEASE DATE 5-18-90	
MATL _____	U/M INCH	SCALE 10:1
FINISH _____		

cinch Connectivity Solutions
 P.O. Box 1732
 Waseca, MN 56093
 1-800-247-8256

TITLE
 JACK ASSEMBLY,
 REAR MOUNT BULKHEAD,
 SMA

SHEET 2 OF 2
 DRAWING NO.
 C - 142-0701-401/410