



Chipsmall Limited consists of a professional team with an average of over 10 year of expertise in the distribution of electronic components. Based in Hongkong, we have already established firm and mutual-benefit business relationships with customers from,Europe,America and south Asia,supplying obsolete and hard-to-find components to meet their specific needs.

With the principle of “Quality Parts,Customers Priority,Honest Operation,and Considerate Service”,our business mainly focus on the distribution of electronic components. Line cards we deal with include Microchip,ALPS,ROHM,Xilinx,Pulse,ON,Everlight and Freescale. Main products comprise IC,Modules,Potentiometer,IC Socket,Relay,Connector.Our parts cover such applications as commercial,industrial, and automotives areas.

We are looking forward to setting up business relationship with you and hope to provide you with the best service and solution. Let us make a better world for our industry!



Contact us

Tel: +86-755-8981 8866 Fax: +86-755-8427 6832

Email & Skype: info@chipsmall.com Web: www.chipsmall.com

Address: A1208, Overseas Decoration Building, #122 Zhenhua RD., Futian, Shenzhen, China



PART NUMBER 142-0761-821	ITEM ① BODY BRASS GOLD PL .00001 MIN OVER NICKEL PL .0001 MIN OVER COPPER PL .00005 MIN	ITEM ② CONTACT BERYLLIUM COPPER GOLD PL .00005 MIN OVER NICKEL PL .00005 MIN OVER COPPER PL .00005 MIN	ITEM ③ INSULATOR TEFLON
-----------------------------	--	---	-------------------------------

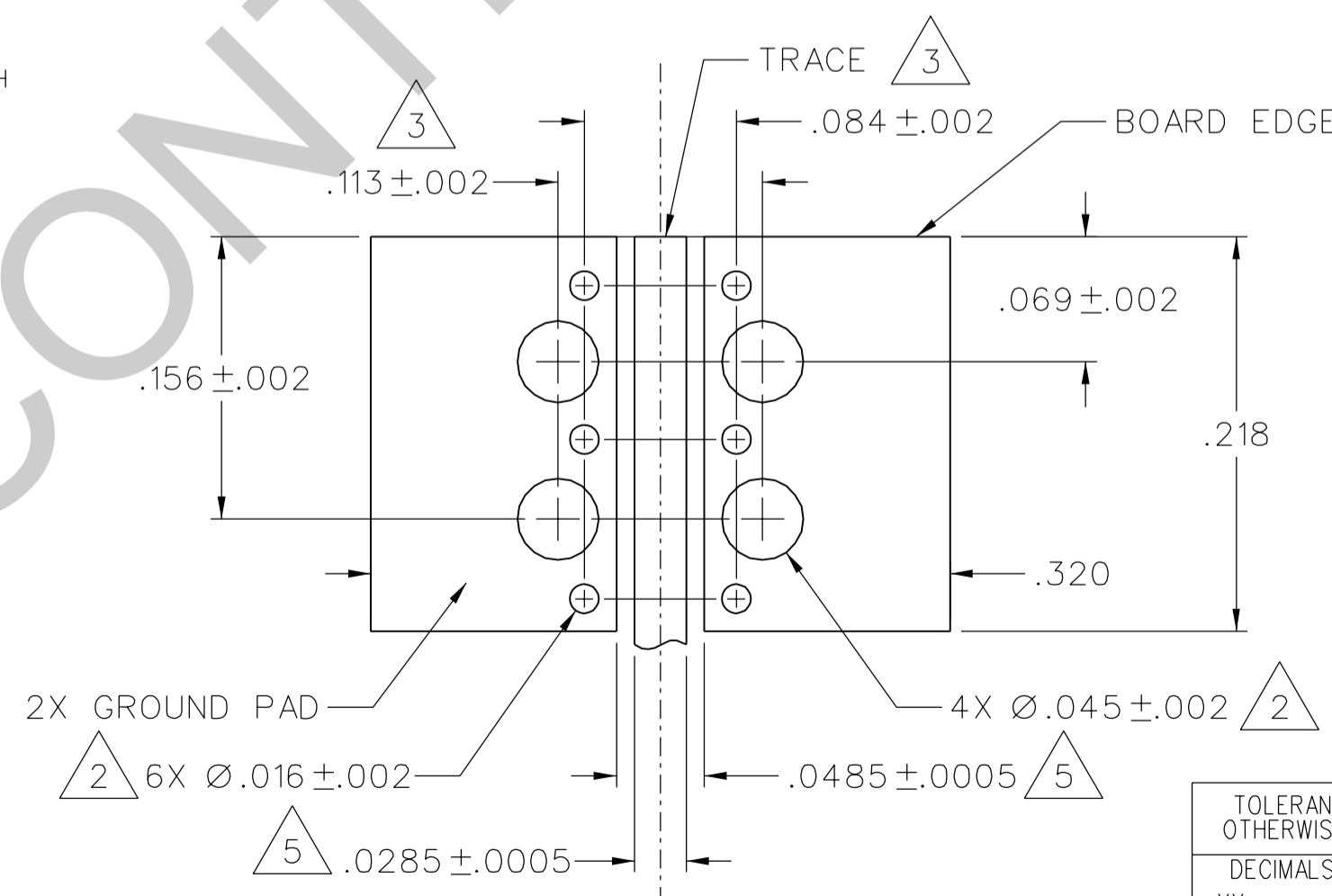
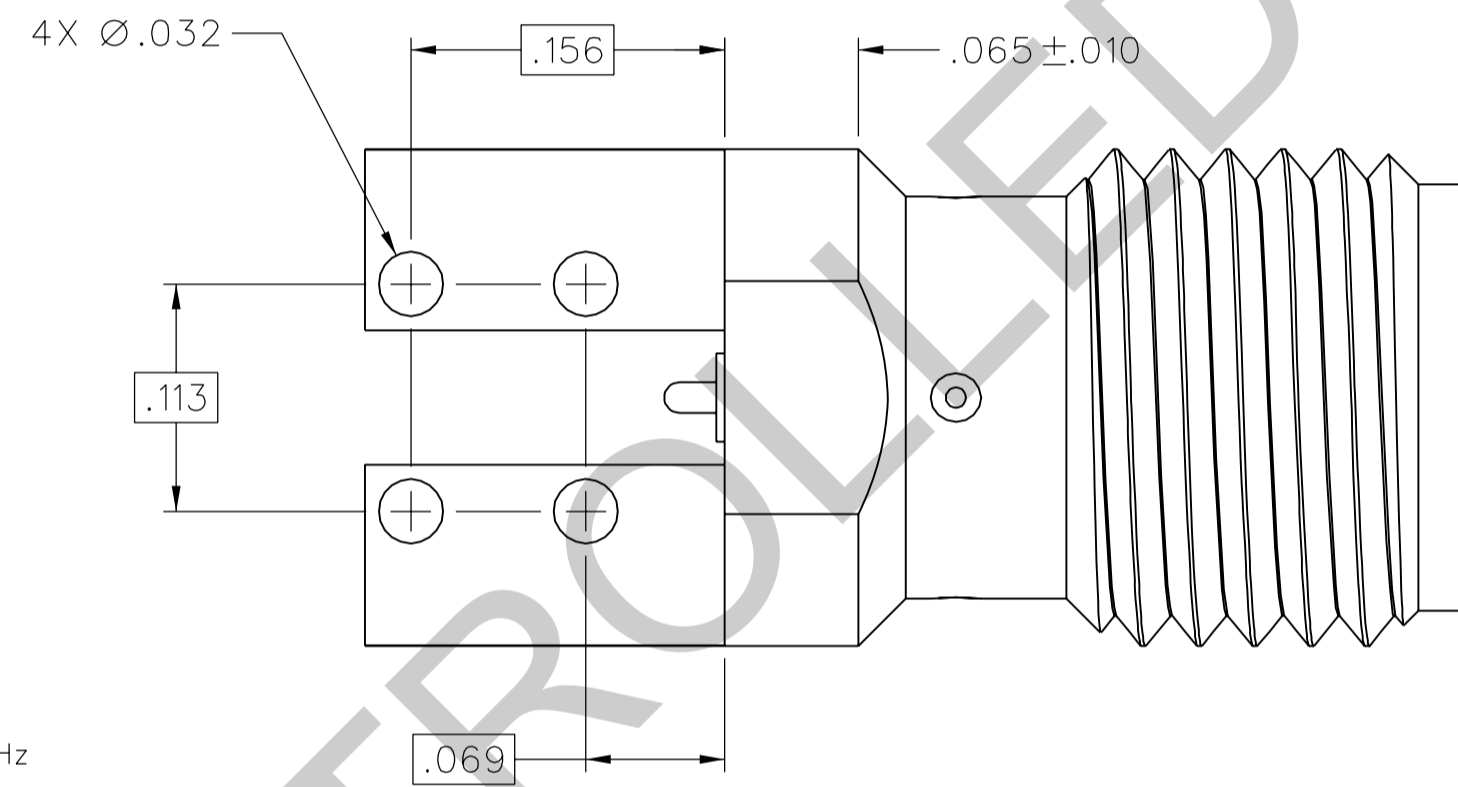
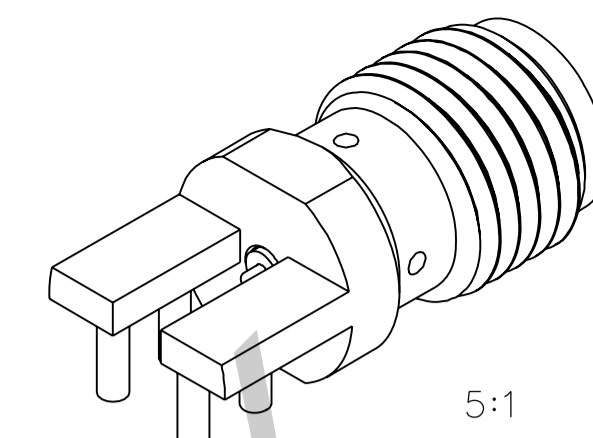
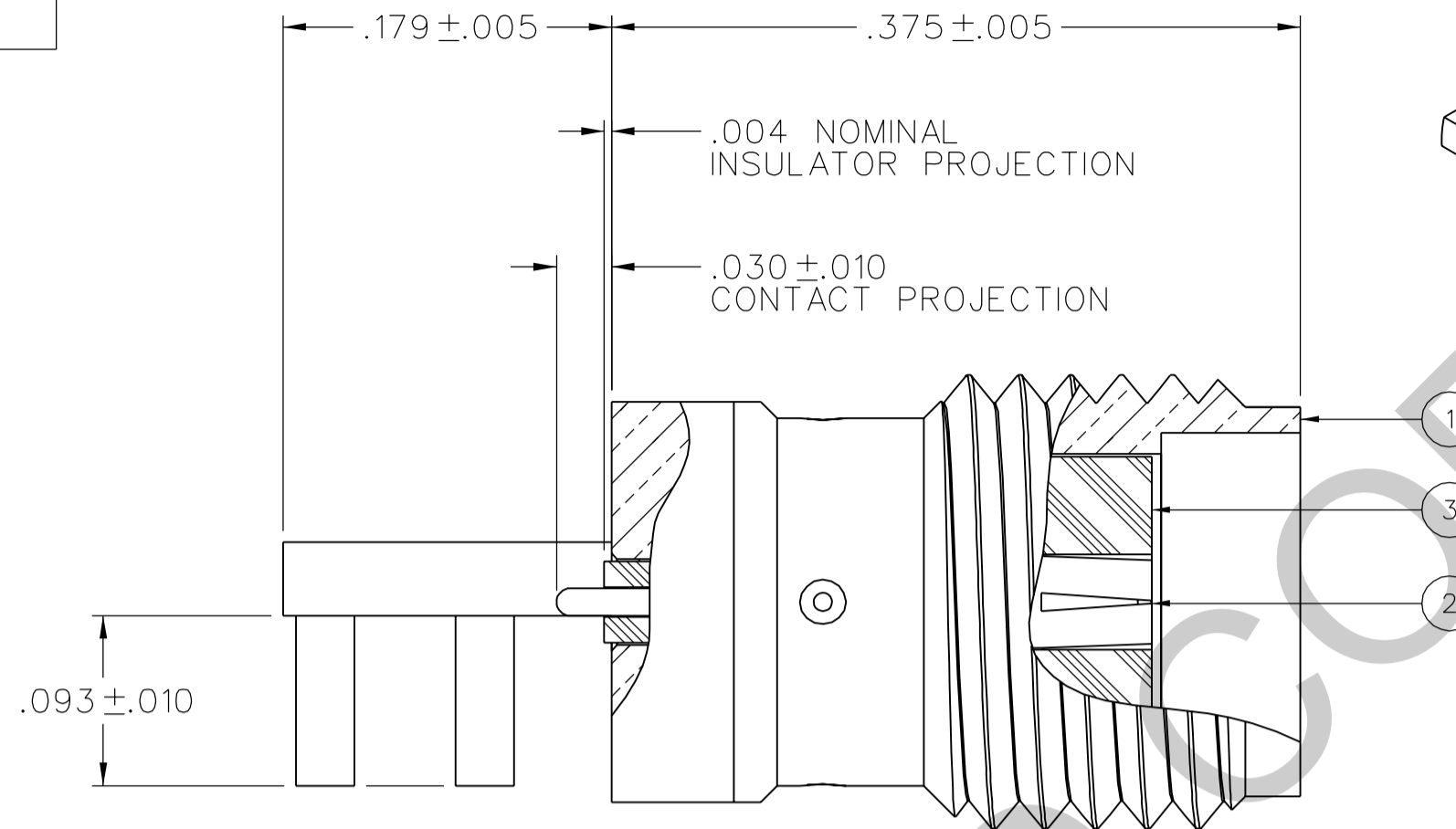
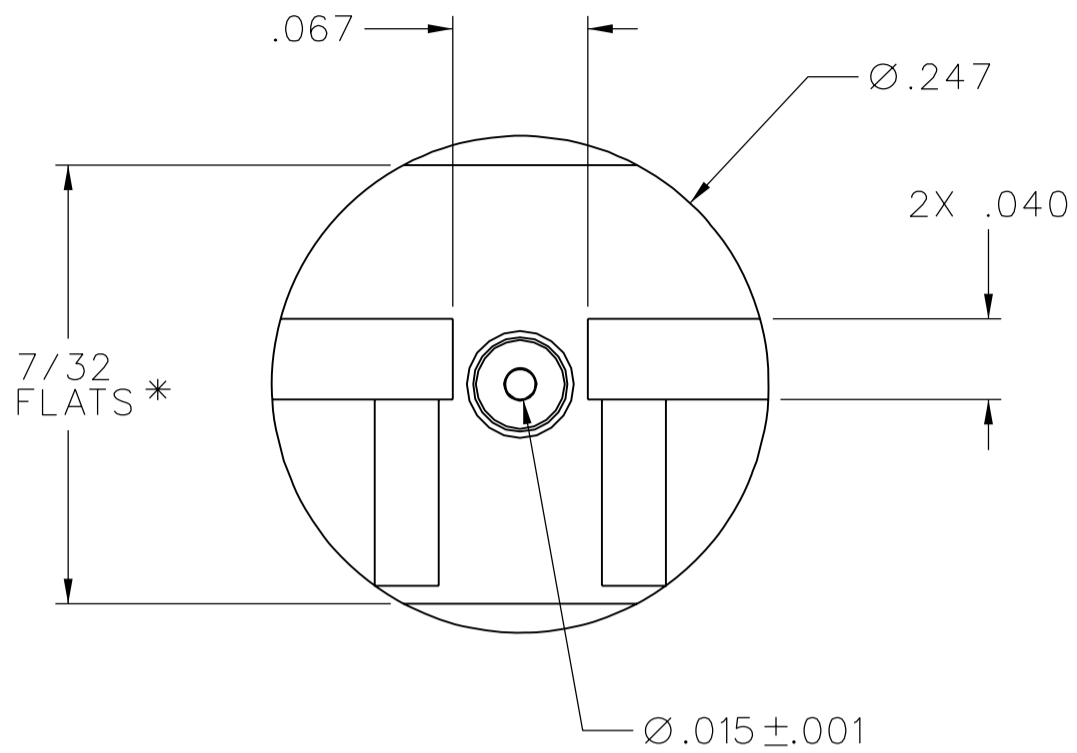

NOTES:

1. SPECIFICATIONS:

IMPEDANCE: 50 OHMS
 FREQUENCY RANGE: 0-26.5 GHz
 VSWR: 1.05+.02F(GHz) MAX AT 0-18 GHz, TYPICALLY < 1.50 AT 18-26.5 GHz
 WORKING VOLTAGE: 170 VRMS MAX AT SEA LEVEL
 DIELECTRIC WITHSTANDING VOLTAGE: 500 VRMS MIN AT SEA LEVEL
 INSULATION RESISTANCE: 1000 MEGOHM MIN
 CONTACT RESISTANCE:
 CENTER CONTACT - INITIAL 3.0 MILLIOHM MAX, AFTER ENVIRONMENTAL 4.0 MILLIOHM MAX
 OUTER CONDUCTOR - INITIAL 2.0 MILLIOHM MAX AFTER ENVIRONMENTAL NOT APPLICABLE
 CORONA LEVEL: 125 VOLTS MIN AT 70,000 FEET
 INSERTION LOSS: NOT APPLICABLE (DEPENDANT UPON APPLICATION)
 RF LEAKAGE: NOT APPLICABLE
 RF HIGH POTENTIAL WITHSTANDING VOLTAGE: 335 VRMS MIN AT 4 AND 7 MHz

MECHANICAL:

ENGAGE/DISENGAGE TORQUE: 2 INCH-POUNDS MAX
 MATING TORQUE: 7-10 INCH POUNDS WHEN BODY SUPPORTED WITH WRENCH
 * 8 INCH POUNDS MAX UNSUPPORTED
 CONTACT RETENTION: 6 LBS MIN AXIAL FORCE ON MATING END
 4 IN-OZ MIN RADIAL TORQUE
 DURABILITY: 500 CYCLES MIN

ENVIRONMENTAL:

(MEETS OR EXCEEDS THE APPLICABLE PARAGRAPH OF MIL-PRF-39012)
 THERMAL SHOCK: MIL-STD-202, METHOD 107, CONDITION B, EXCEPT 115°C HIGH TEMP
 OPERATING TEMPERATURE: -65 DEG C TO 165 DEG C
 CORROSION: MIL-STD-202, METHOD 101, CONDITION B
 SHOCK: MIL-STD-202, METHOD 213, CONDITION I
 VIBRATION: MIL-STD-202, METHOD 204, CONDITION D
 MOISTURE RESISTANCE: MIL-STD-202, METHOD 106

②. ALL HOLES PLATED THRU ENTIRE CIRCUIT BOARD STACKUP.

③. HOLE PATTERNS SYMMETRICAL ABOUT CENTER OF CPW TRACE.

4. FOR OPTIMUM CIRCUIT BOARD HIGH FREQUENCY PERFORMANCE:
 A. MAINTAIN SOLID GROUND PLANE BELOW HF SUBSTRATE.
 B. CONTROL PULLBACK OF TRACE AND GROUND FROM BOARD EDGE.
 C. CONTINUE GROUNDED COPLANAR LINE BEYOND GROUND PADS.
 D. PLACE 16 MIL DIA GROUND VIAS ON BOTH SIDES OF COPLANAR WAVEGUIDE LINE AT 50 MIL INTERVALS ALONG ENTIRE LENGTH.
 E. IMMERSION GOLD PLATE (ENIG) ALL CONDUCTORS PER IPC-4552.

⑤. REFERENCE DIMENSIONS FOR 50 OHM GROUNDED CPW LINE, USING ROGERS RO4003, 16 MIL HIGH FREQUENCY CIRCUIT BOARD SUBSTRATE:
 TRACE WIDTH = 28.5 MILS
 GROUND GAPS = 10 MILS
 CONDUCTOR THICKNESS = 1.4 MIL (INCLUDES PLATING)

6. EMERSON NETWORK POWER CONNECTIVITY SOLUTIONS HIGH FREQUENCY END LAUNCH CONNECTORS ARE COVERED UNDER U.S. PATENT NUMBER 7,344,381.

MOUNTING FOOTPRINT
 10:1 (TOP VIEW, INCLUDING TRACE DIMENSIONS)

DRAWING NO. C - 142-0761-821/830

0 REVISIONS

ENGINEERING RELEASE

1	11-5-04	JRK			12-15-04	ECN 49542
---	---------	-----	--	--	----------	-----------

ADDED NOTE: 6

 * REVISION NUMBER FOLLOWED BY AN ALPHA *
 * CHARACTER INDICATES DRAWING CLARIFICATION *
 * CATION OR PART NUMBER ADDITION ONLY. *

1a	4-14-08	PAT	JRK	MJL	5-7-08	ECN 51477
----	---------	-----	-----	-----	--------	-----------

CUSTOMER DRAWING

THIS DRAWING TO BE INTERPRETED PER ASME Y 14.5M - 1994

"μSTATION"

COMPANY CONFIDENTIAL

TOLERANCE UNLESS OTHERWISE SPECIFIED		DRAWN BY	DATE
DECIMALS	mm	JRK	11-1-04
.XX		CHECKED BY	DATE
.XXX ±.003			
MATL		APPROVED BY	DATE
		JRK	12-15-04
FINISH		RELEASE DATE	2-15-04
		U/M INCH	SCALE 10:1



TITLE
 HIGH FREQ END LAUNCH SMA JACK ASSEMBLY, PC MOUNT, 15 MIL PIN

SHEET 2 OF 2
 DRAWING NO. C - 142-0761-821/830