



Chipsmall Limited consists of a professional team with an average of over 10 year of expertise in the distribution of electronic components. Based in Hongkong, we have already established firm and mutual-benefit business relationships with customers from,Europe,America and south Asia,supplying obsolete and hard-to-find components to meet their specific needs.

With the principle of "Quality Parts,Customers Priority,Honest Operation,and Considerate Service",our business mainly focus on the distribution of electronic components. Line cards we deal with include Microchip,ALPS,ROHM,Xilinx,Pulse,ON,Everlight and Freescale. Main products comprise IC,Modules,Potentiometer,IC Socket,Relay,Connector.Our parts cover such applications as commercial,industrial, and automotives areas.

We are looking forward to setting up business relationship with you and hope to provide you with the best service and solution. Let us make a better world for our industry!



Contact us

Tel: +86-755-8981 8866 Fax: +86-755-8427 6832

Email & Skype: info@chipsmall.com Web: www.chipsmall.com

Address: A1208, Overseas Decoration Building, #122 Zhenhua RD., Futian, Shenzhen, China



PART NUMBER	ITEM ① BODY	ITEM ② CONTACT	ITEM ③ INSULATOR	ITEM ④ CRIMP SLEEVE	ITEM ⑤ LOCKWASHER	ITEM ⑥ NUT
142-9303-411	COPPER ALLOY GOLD PL .00005 MIN OVER COPPER PL .00005 MIN	BERYLLIUM COPPER GOLD PL .00005 MIN OVER COPPER PL .00005 MIN	TEFLON	COPPER ALLOY GOLD PL .00005 MIN OVER COPPER PL .00005 MIN	COPPER ALLOY GOLD PL .00005 MIN OVER COPPER PL .00005 MIN	COPPER ALLOY GOLD PL .00005 MIN OVER COPPER PL .00005 MIN
142-9303-414	COPPER ALLOY SILVER PL .00005 MIN OVER COPPER PL .00005 MIN	BERYLLIUM COPPER SILVER PL .00005 MIN OVER COPPER PL .00005 MIN	TEFLON	COPPER ALLOY SILVER PL .00005 MIN OVER COPPER PL .00005 MIN	COPPER ALLOY SILVER PL .00005 MIN OVER COPPER PL .00005 MIN	COPPER ALLOY SILVER PL .00005 MIN OVER COPPER PL .00005 MIN

DRAWING NO. C - 142-9303-411/420	
0	REVISIONS
ENGINEERING RELEASE	
1	5-14-07 P A T J B M J U S J C N 5-15-07 ECN 51027

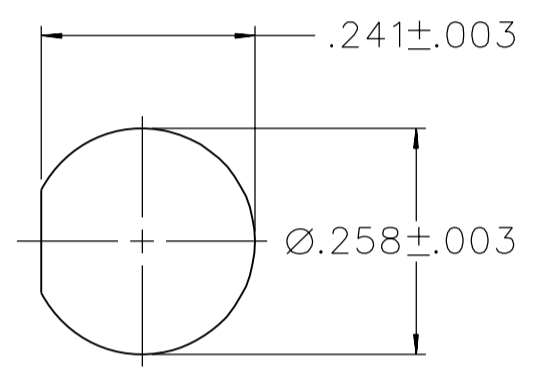

MOUNTING HOLE
4:1

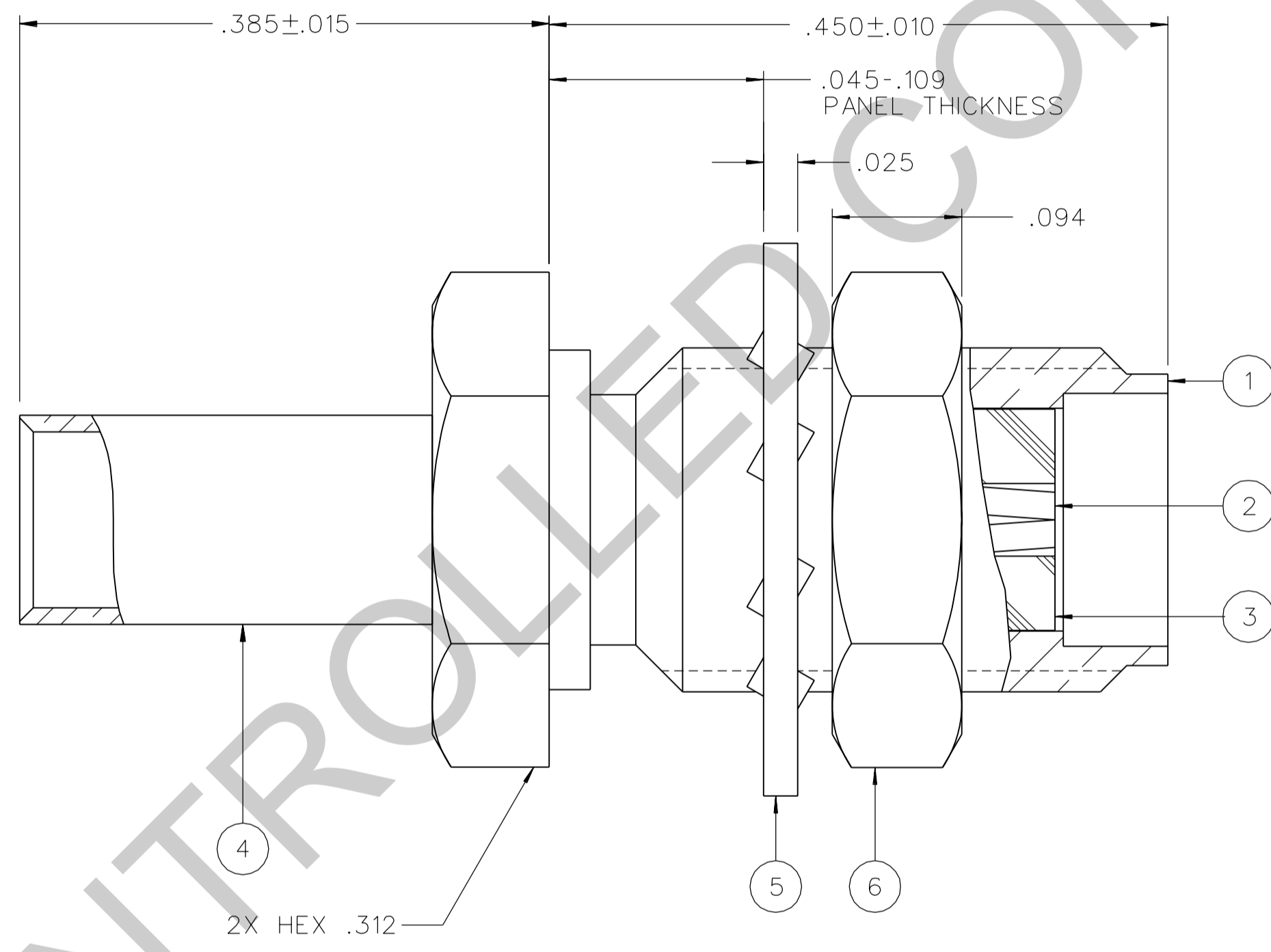

NOTES:

1. SPECIFICATIONS:
- IMPEDANCE: 50 OHMS
 FREQUENCY RANGE: 0-12.4 GHz
 VSWR: 1.15+.02 F MAX (F IN GHz)
 WORKING VOLTAGE: 250 VRMS MAX AT SEA LEVEL
 DIELECTRIC WITHSTANDING VOLTAGE: 750 VRMS MIN AT SEA LEVEL
 INSULATION RESISTANCE: 5000 MEGOHM MIN
 CONTACT RESISTANCE:
 CENTER CONTACT - INITIAL 3.0 MILLIOHM MAX, AFTER ENVIRONMENTAL 4.0 MILLIOHM MAX
 OUTER CONDUCTOR - INITIAL 2.0 MILLIOHM MAX, AFTER ENVIRONMENTAL NOT APPLICABLE
 BODY TO CABLE - 0.5 MILLIOHM MAX (GOLD PLATED) 5.0 MILLIOHM MAX (NICKEL PLATED)
 CORONA LEVEL: 190 VOLTS MIN AT 70,000 FEET
 INSERTION LOSS: .06√F dB MAX (F IN GHz) AT 6 GHz
 RF LEAKAGE: -60 DB MIN AT 2.5 GHz
 RF HIGH POTENTIAL WITHSTANDING VOLTAGE: 500 VRMS MIN AT 4 AND 7 MHz
- MECHANICAL:
- ENGAGE/DISENGAGE TORQUE: 2 INCH POUNDS MAX
 MATING TORQUE: 7-10 INCH POUNDS
 COUPLING PROOF TORQUE: NOT APPLICABLE
 COUPLING NUT RETENTION: NOT APPLICABLE
 CONTACT RETENTION: 6 LBS MIN
 CABLE ACCEPTABILITY: RG 188, RG 316, RG 161, RG 174
 CABLE HEX CRIMP SIZE: .128
 CONTACT CRIMP TOOL: MIL M22520/1-01
 CABLE RETENTION: 20 LBS MIN AXIAL FORCE
 DURABILITY: 500 CYCLES MIN
- ENVIRONMENTAL:
- (MEETS OR EXCEEDS THE APPLICABLE PARAGRAPH OF MIL-PRF-39012)
 THERMAL SHOCK: MIL-STD-202, METHOD 107, CONDITION B, EXCEPT 85° C HIGH TEMP
 OPERATING TEMPERATURE: -65° C TO 165° C
 CORROSION: MIL-STD-202, METHOD 101, CONDITION B
 SHOCK: MIL-STD-202, METHOD 213, CONDITION I
 VIBRATION: MIL-STD-202, METHOD 204, CONDITION D
 MOISTURE RESISTANCE: MIL-STD-202, METHOD 106

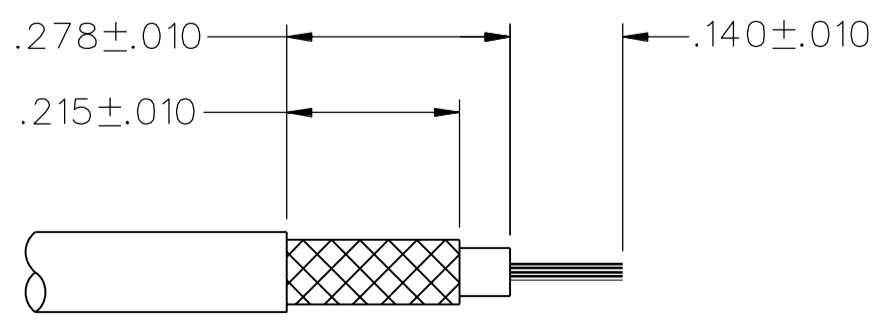

CABLE STRIP DIMENSIONS
4:1

TOLERANCE UNLESS OTHERWISE SPECIFIED	DRAWN BY RJB	DATE 5-14-07
DECIMALS	CHECKED BY RJB	DATE 5-15-07
.XX	APPROVED BY JCN	DATE 5-15-07
.XXX	RELEASE DATE	5-15-07
MATL	U/M	INCH
FINISH	SCALE	10:1

cinch Connectivity Solutions
 a bel group
 P.O. Box 1732
 Waseca, MN 56093
 1-800-247-8256

TITLE
 JACK ASSEMBLY,
 STRAIGHT CABLED BULKHEAD,
 SMA, RG 316, NON-MAGNET

SHEET 2 OF 2
 DRAWING NO.
 C - 142-9303-411/420

CUSTOMER DRAWING

THIS DRAWING TO BE INTERPRETED PER ASME Y 14.5M - 1994

"μSTATION"

COMPANY CONFIDENTIAL