



Chipsmall Limited consists of a professional team with an average of over 10 year of expertise in the distribution of electronic components. Based in Hongkong, we have already established firm and mutual-benefit business relationships with customers from,Europe,America and south Asia,supplying obsolete and hard-to-find components to meet their specific needs.

With the principle of “Quality Parts,Customers Priority,Honest Operation,and Considerate Service”,our business mainly focus on the distribution of electronic components. Line cards we deal with include Microchip,ALPS,ROHM,Xilinx,Pulse,ON,Everlight and Freescale. Main products comprise IC,Modules,Potentiometer,IC Socket,Relay,Connector.Our parts cover such applications as commercial,industrial, and automotives areas.

We are looking forward to setting up business relationship with you and hope to provide you with the best service and solution. Let us make a better world for our industry!



Contact us

Tel: +86-755-8981 8866 Fax: +86-755-8427 6832

Email & Skype: info@chipsmall.com Web: www.chipsmall.com

Address: A1208, Overseas Decoration Building, #122 Zhenhua RD., Futian, Shenzhen, China



LOC	DIST	REVISIONS			
P	LTR	DESCRIPTION	DATE	DWN	APVD
A		RLSD PER D06-057	24MAR2006	RGV	TJV
A1		REV PER ECO-10-015982	10AUG2010	HM	DCM

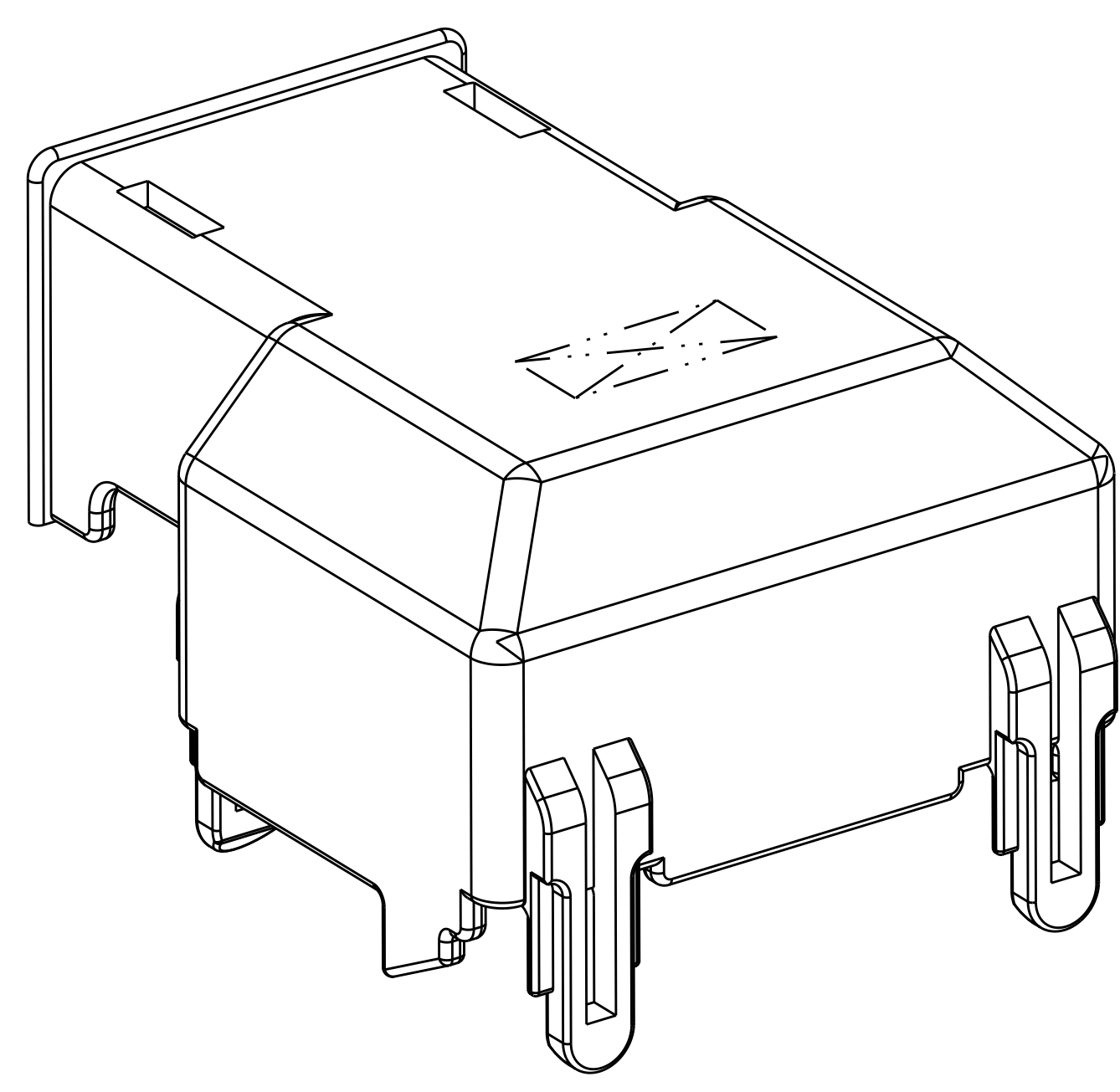
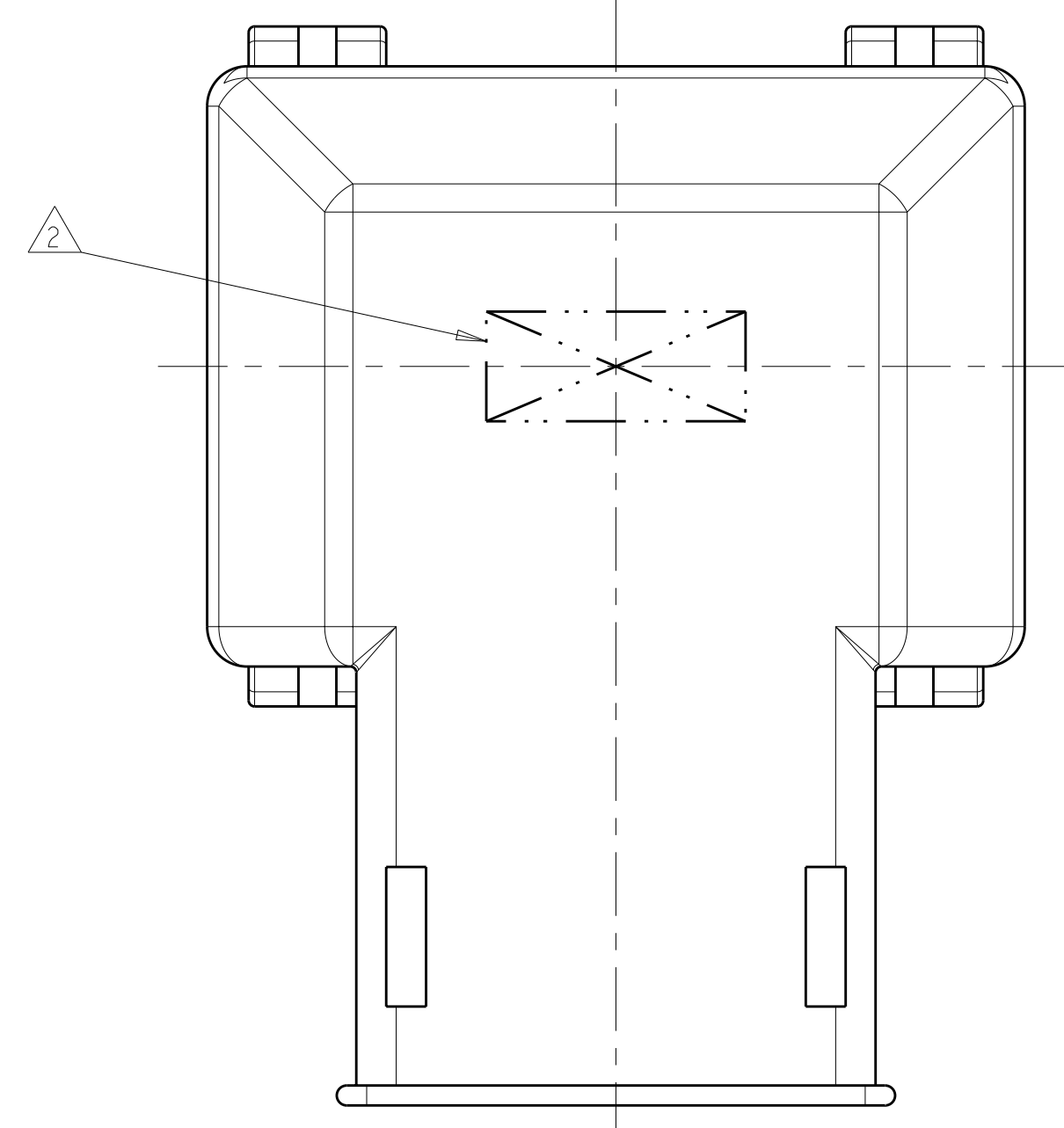

- 1 MATERIAL: PBT-GF15
COLOR: BLACK
- 2 COMPANY LOGO LOCATED APPROXIMATELY AS SHOWN.
- 3 MOLD CAVITY I.D. & RECYCLING CODE >PBT-GF15< AS SHOWN.
- 4. 25% MAXIMUM REGRIND.
- 5 PART NUMBERS APPROXIMATELY AS SHOWN AS STATED IN PART NUMBER TABLE.
- 6 DATE CODE APPROXIMATELY AS SHOWN.

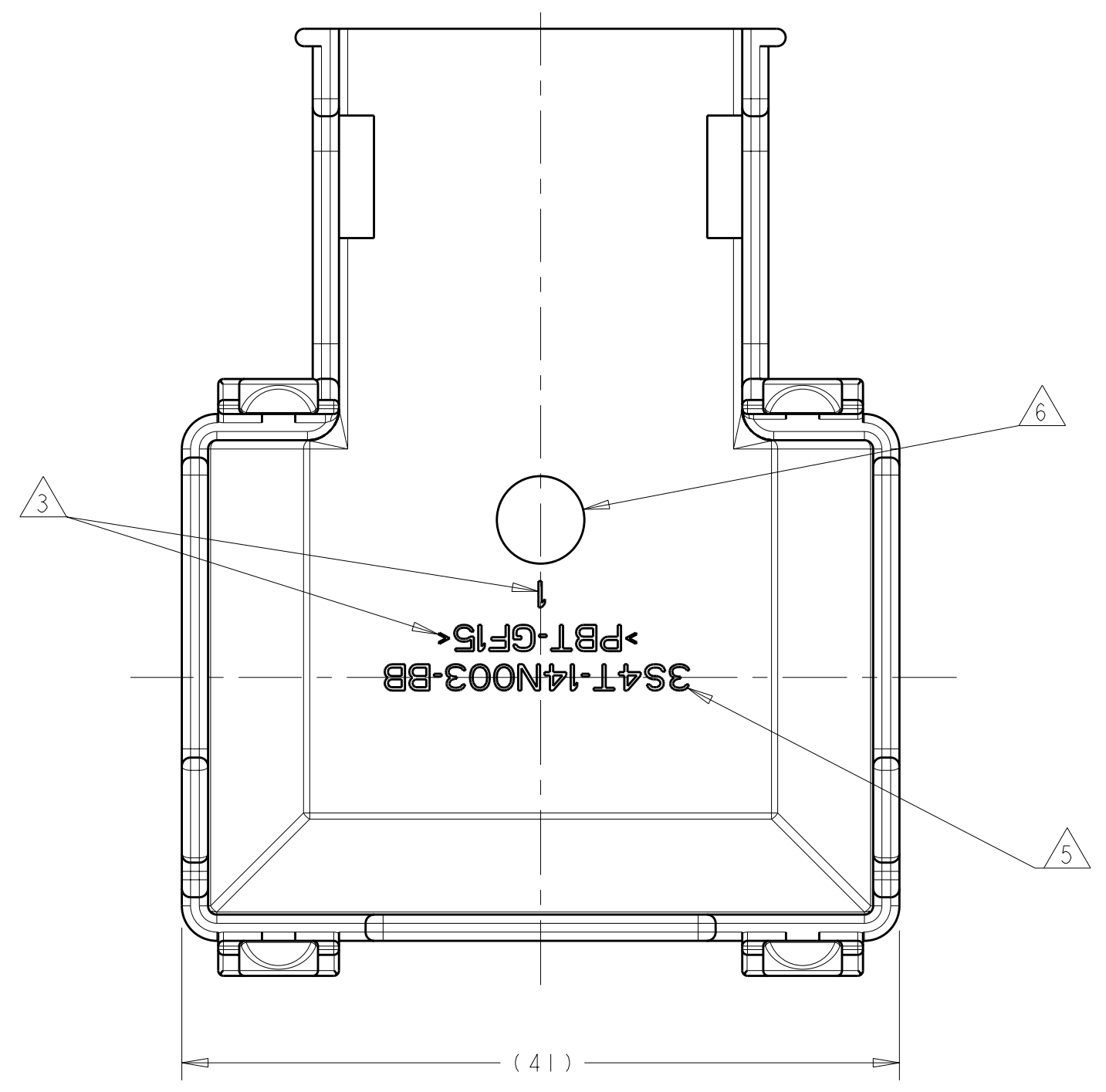
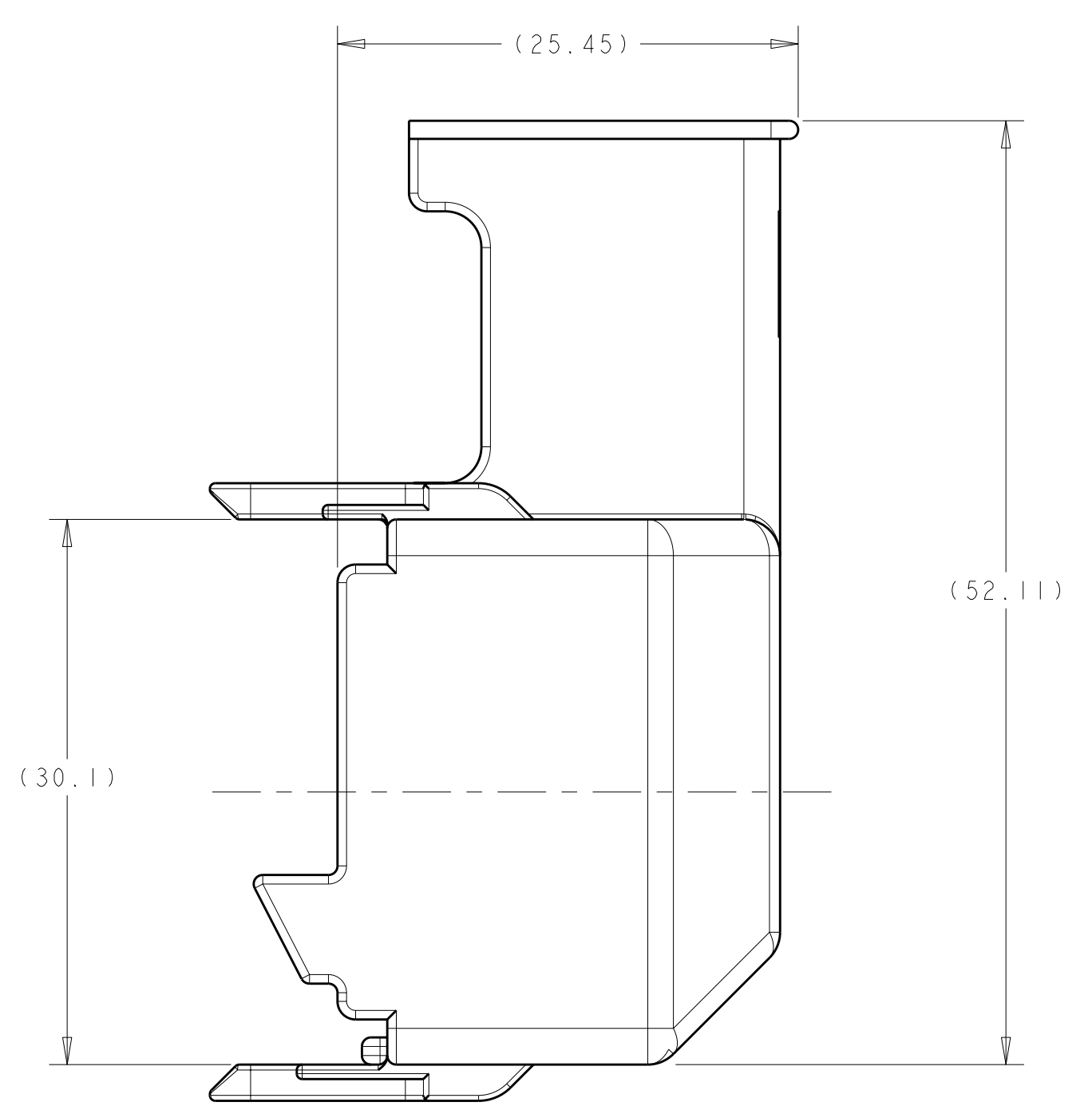
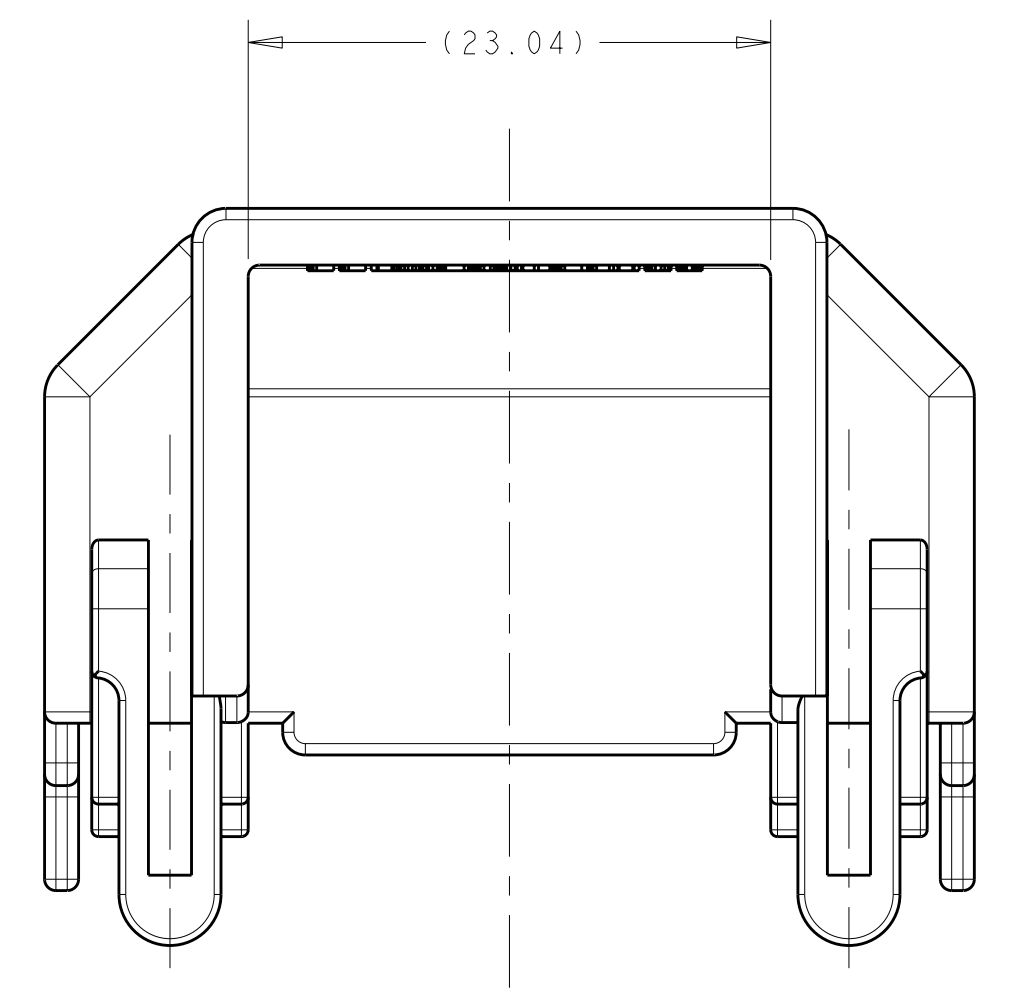

DIMENSIONS: mm 		TOLERANCES UNLESS OTHERWISE SPECIFIED: 9 PLC ± 1 PLC ±0.3 2 PLC ±0.10 3 PLC ± 4 PLC ± ANGLES ±1° FINISH -		DWN R. VESTAL 24MAR2006 CHK T. VALASEK 24MAR2006 APVD T. VALASEK 24MAR2006 PRODUCT SPEC APPLICATION SPEC WEIGHT CUSTOMER DRAWING		Tyco Electronics Harrisburg, PA 17105-3608 NAME 50-WAY WIRE DRESSING SIZE CAGE CODE DRAWING NO A100779C=1438126 SCALE 3:1 SHEET 1 OF 1 REV A1	
MATERIAL - FINISH -		3S4T-14N003-BB PBT-GF15		3S4T-14N003-BB CUSTOMER PART NO.		1438126-1 PART NUMBER	