



Chipsmall Limited consists of a professional team with an average of over 10 year of expertise in the distribution of electronic components. Based in Hongkong, we have already established firm and mutual-benefit business relationships with customers from,Europe,America and south Asia,supplying obsolete and hard-to-find components to meet their specific needs.

With the principle of “Quality Parts,Customers Priority,Honest Operation,and Considerate Service”,our business mainly focus on the distribution of electronic components. Line cards we deal with include Microchip,ALPS,ROHM,Xilinx,Pulse,ON,Everlight and Freescale. Main products comprise IC,Modules,Potentiometer,IC Socket,Relay,Connector.Our parts cover such applications as commercial,industrial, and automotives areas.

We are looking forward to setting up business relationship with you and hope to provide you with the best service and solution. Let us make a better world for our industry!



## Contact us

Tel: +86-755-8981 8866 Fax: +86-755-8427 6832

Email & Skype: info@chipsmall.com Web: www.chipsmall.com

Address: A1208, Overseas Decoration Building, #122 Zhenhua RD., Futian, Shenzhen, China



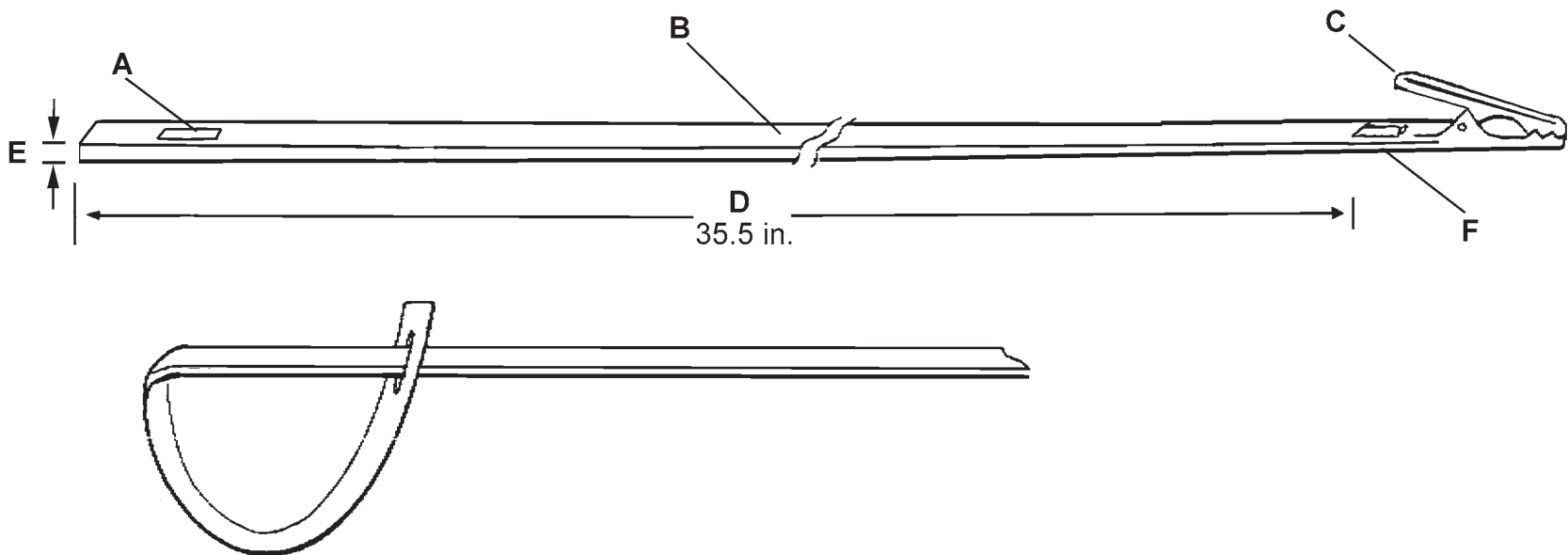

### Description:

Lightweight disposable wrist strap, ideal for field service applications. One size fits all. The static dissipative vinyl has a surface resistance of  $10^7$  ohms, which yields an effective resistance to ground.

### Applications:

The disposable wrist strap is ideal for plant visitors and short term workers. Because of its low cost, it can also be shipped with loaded PC boards and other sensitive materials to provide the means for the field service technician to take appropriate ESD precautions.

#### RoHS Compliance Statement

None of the following materials are intentionally added in manufacturing this product: lead, mercury, cadmium, hexavalent chromium, polybrominated biphenyls (PBB) or polybrominated diphenyl ethers (PBDE) as outlined in the Directive 2002/95/EC Article 4.1. See Desco Industries Inc. letter on-line at [Desco.com](http://Desco.com).

### Key:

- A. Adjustable wrist strap portion with break-away feature.
- B. Material, vinyl static dissipative navy blue (both sides).
- C. Mini alligator clip to attach to ground.
- D. Ribbon length: 35.5 inches.
- E. Thickness of material: 15 mils +/- 10%.
- F. Mini alligator clip is crimped to the ribbon.
- G. Flame resistant
- H. Total resistance from clip to adjustable portion  $10^7$  ohms.



Made in America



### WRIST STRAP, VINYL, DISPOSABLE

# DESCO

DESCO WEST: 3651 WALNUT AVE., CHINO, CA 91710 WEB SITE: [www.desco.com](http://www.desco.com)  
PHONE (909) 627-8178 FAX (909) 627-7449

DESCO EAST: 90 HUDSON RD, CANTON, MA 02021-1407  
PHONE (781) 821-8370 FAX (781) 575-0172

**DRAWING NUMBER**  
14401

**DATE:**  
7/06