



Chipsmall Limited consists of a professional team with an average of over 10 year of expertise in the distribution of electronic components. Based in Hongkong, we have already established firm and mutual-benefit business relationships with customers from,Europe,America and south Asia,supplying obsolete and hard-to-find components to meet their specific needs.

With the principle of “Quality Parts,Customers Priority,Honest Operation,and Considerate Service”,our business mainly focus on the distribution of electronic components. Line cards we deal with include Microchip,ALPS,ROHM,Xilinx,Pulse,ON,Everlight and Freescale. Main products comprise IC,Modules,Potentiometer,IC Socket,Relay,Connector.Our parts cover such applications as commercial,industrial, and automotives areas.

We are looking forward to setting up business relationship with you and hope to provide you with the best service and solution. Let us make a better world for our industry!



Contact us

Tel: +86-755-8981 8866 Fax: +86-755-8427 6832

Email & Skype: info@chipsmall.com Web: www.chipsmall.com

Address: A1208, Overseas Decoration Building, #122 Zhenhua RD., Futian, Shenzhen, China



Sensor/actuator box - SACB-4/ 4-L-SC SCO P - 1452987

Please be informed that the data shown in this PDF Document is generated from our Online Catalog. Please find the complete data in the user's documentation. Our General Terms of Use for Downloads are valid (<http://phoenixcontact.com/download>)



Sensor/actuator box, application: Standard, connection method: M12-SPEEDCON-socket Plastic, number of slots: 4, number of positions: 4, coding: A - standard, slot assignment: single, status display: yes, pnp; master cable connection: Spring-cage connection 180°, shielding: no

Why buy this product

- Safety in the field, thanks to molded housing and high degree of protection
- Flexible, distributed bundling of signals in one master cable
- Convenient: increased machine availability thanks to quick and easy diagnostics
- Save time, thanks to installation with SPEEDCON fast locking system
- Flexible: distributor box with connector hood for on-site assembly



Key Commercial Data

Packing unit	1 STK
GTIN	 4 046356 553605
GTIN	4046356553605

Technical data

General

Rated voltage	24 V DC
Max. operating voltage U_{max}	30 V DC
Current carrying capacity per I/O signal	2 A
Current carrying capacity per slot	4 A
Total rated current	12 A
Number of positions	4
Number of slots	4
Flammability rating according to UL 94	V0
Sensor/actuator connection system	M12-SPEEDCON-socket
Note	When connecting the signal lines to the black PCB terminal blocks, please use a 0.4 x 2.0 mm screwdriver.

Sensor/actuator box - SACB-4/ 4-L-SC SCO P - 1452987

Technical data

General

	<p>The black PCB terminal blocks only require a minimal amount of operating force. Screwdriver: SZS 0,4X2,0 - 1205202 Using larger screwdrivers or excessive force may damage the PCB terminal blocks. When using ferrules, the wires can be inserted straight into the PCB terminal blocks without opening the clamping area.</p>
	<p>Item 1412058 SACB-4/ 8-L-PT SCO P is a version with the same connection cross section for signals and energy supply from 0.2 mm² to 1 mm². This sensor/actuator box with double slot assignment also features a master cable connection with Push-in connection terminal blocks.</p>

Ambient conditions

Degree of protection	IP65
	IP67
Ambient temperature (operation)	-25 °C ... 80 °C

Local diagnostics function

Local diagnostics	Supply voltage Green LED
	Status display I/O Yellow LED

Master cable data/connection data

Connection method	Spring-cage connection
Conductor cross section min. (signal)	0.2 mm ²
Conductor cross section max. (signal)	0.5 mm ²
Conductor cross section AWG min. (signal)	24
Conductor cross section AWG max. (signal)	20
Stripping length (signal)	6 mm
Conductor cross section min. (energy)	0.2 mm ²
Conductor cross section max. (energy)	1.5 mm ²
Conductor cross section AWG min. (energy)	24
Conductor cross section AWG max. (energy)	16
Stripping length (power)	10 mm
External cable diameter min.	7 mm
External cable diameter max.	12 mm
Stripping length	50 mm (Master cable)
Tightening torque, cover screw	1 Nm
Tightening torque, union nut	2.5 Nm
Tightening torque slot sensor/actuator cable	0.4 Nm
Tightening torque of mounting screw for fixing the housing	0.5 Nm

Insulation material

Housing material	PBT
Material of the moulding mass	PUR
Contact material	Cu alloy

Sensor/actuator box - SACB-4/ 4-L-SC SCO P - 1452987

Technical data

Insulation material

Contact surface material	gold-plated
Contact carrier material	PA
Material of threaded sleeve	PBT
O-ring material	NBR
Sealing material	NBR (Connector hood)

Pin assignment

Slot/position = Wire color or connection	1 / 4 (A) = WH
	2 / 4 (A) = GN
	3 / 4 (A) = YE
	4 / 4 (A) = GY
	1-4 / 1 (+ 24 V) = BN
	1-4 / 3 (0 V) = BU
	1-4 / 5 (PE) = GN/YE

Standards and Regulations

Standard designation	M12 connector
Standards/regulations	IEC 61076-2-101
Connection in acc. with standard	CUL
Flammability rating according to UL 94	V0

Environmental Product Compliance

REACH SVHC	Lead 7439-92-1
China RoHS	Environmentally friendly use period: unlimited = EFUP-e
	No hazardous substances above threshold values

Drawings

Schematic diagram

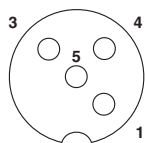

M12 slot, socket, 4-pos.

Dimensional drawing

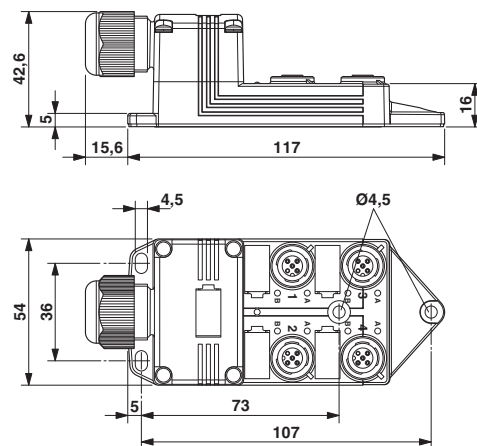

Sensor/actuator box - SACB-4/ 4-L-SC SCO P - 1452987

Circuit diagram

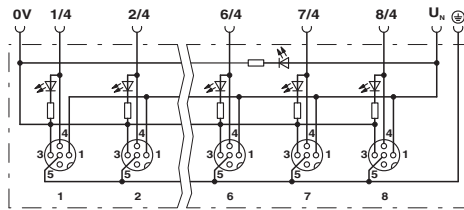

Approvals

Approvals

Approvals

UL Recognized / cUL Recognized / EAC / cULus Recognized

Ex Approvals

Approval details

UL Recognized		http://database.ul.com/cgi-bin/XYV/template/LISEXT/1FRAME/index.htm	FILE E 118976
Nominal voltage UN		24 V	
Nominal current IN		4 A	

cUL Recognized		http://database.ul.com/cgi-bin/XYV/template/LISEXT/1FRAME/index.htm	FILE E 118976
Nominal voltage UN		24 V	

EAC		RU C- DE.AI30.B.01102
-----	--	--------------------------

Sensor/actuator box - SACB-4/ 4-L-SC SCO P - 1452987

Approvals

cULus Recognized



<http://database.ul.com/cgi-bin/XYV/template/LISEXT/1FRAME/index.htm>

Phoenix Contact 2018 © - all rights reserved
<http://www.phoenixcontact.com>

PHOENIX CONTACT GmbH & Co. KG
Flachsmarktstr. 8
32825 Blomberg
Germany
Tel. +49 5235 300
Fax +49 5235 3 41200
<http://www.phoenixcontact.com>