



Chipsmall Limited consists of a professional team with an average of over 10 year of expertise in the distribution of electronic components. Based in Hongkong, we have already established firm and mutual-benefit business relationships with customers from,Europe,America and south Asia,supplying obsolete and hard-to-find components to meet their specific needs.

With the principle of “Quality Parts,Customers Priority,Honest Operation,and Considerate Service”,our business mainly focus on the distribution of electronic components. Line cards we deal with include Microchip,ALPS,ROHM,Xilinx,Pulse,ON,Everlight and Freescale. Main products comprise IC,Modules,Potentiometer,IC Socket,Relay,Connector.Our parts cover such applications as commercial,industrial, and automotives areas.

We are looking forward to setting up business relationship with you and hope to provide you with the best service and solution. Let us make a better world for our industry!



Contact us

Tel: +86-755-8981 8866 Fax: +86-755-8427 6832

Email & Skype: info@chipsmall.com Web: www.chipsmall.com

Address: A1208, Overseas Decoration Building, #122 Zhenhua RD., Futian, Shenzhen, China



LOC		DIST		REVISIONS			
AD	00	P	LTN	DESCRIPTION	DATE	DWN	APVD
		F		REVISED PER ECO-15-000706	16JAN2015	AP	RP

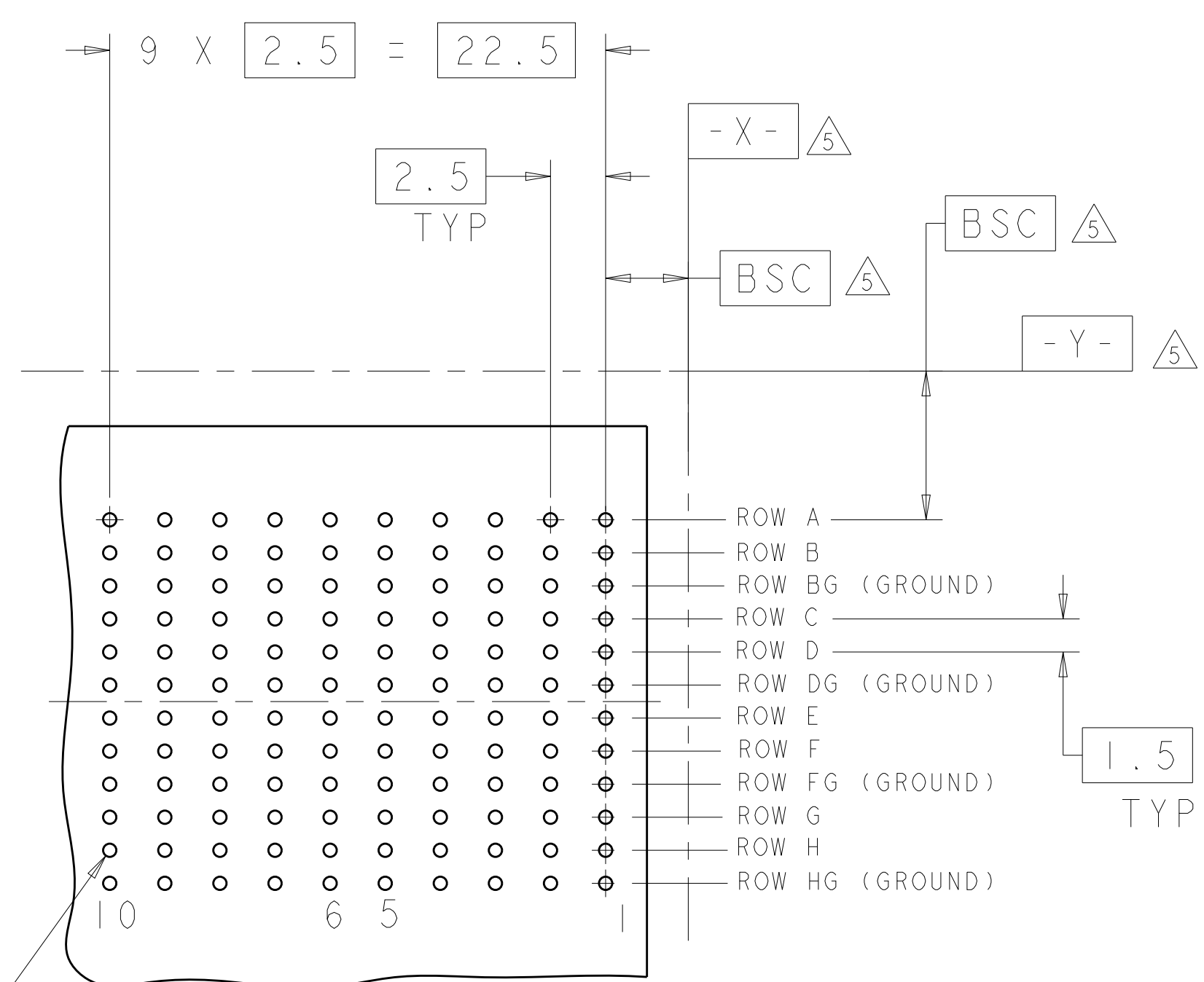
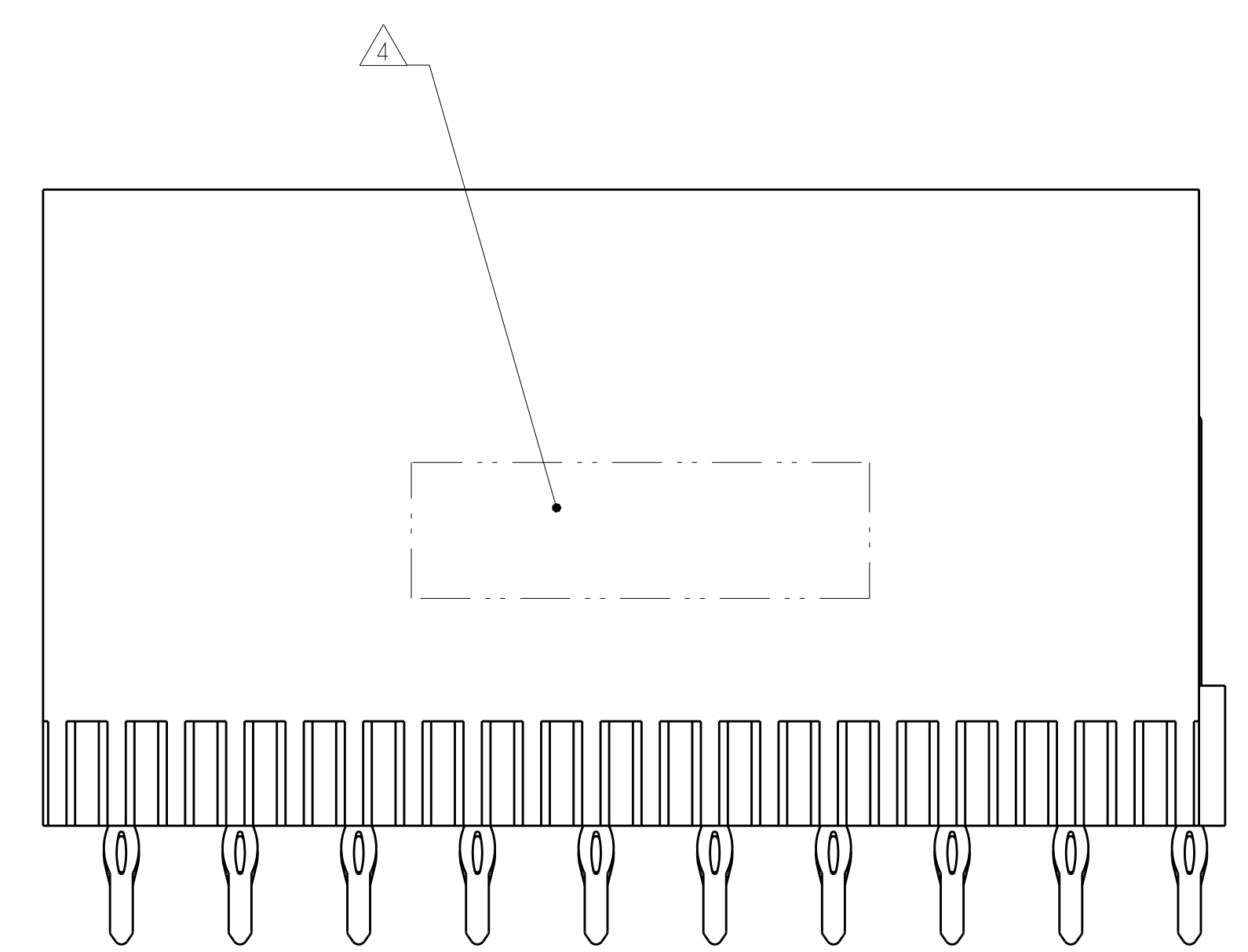
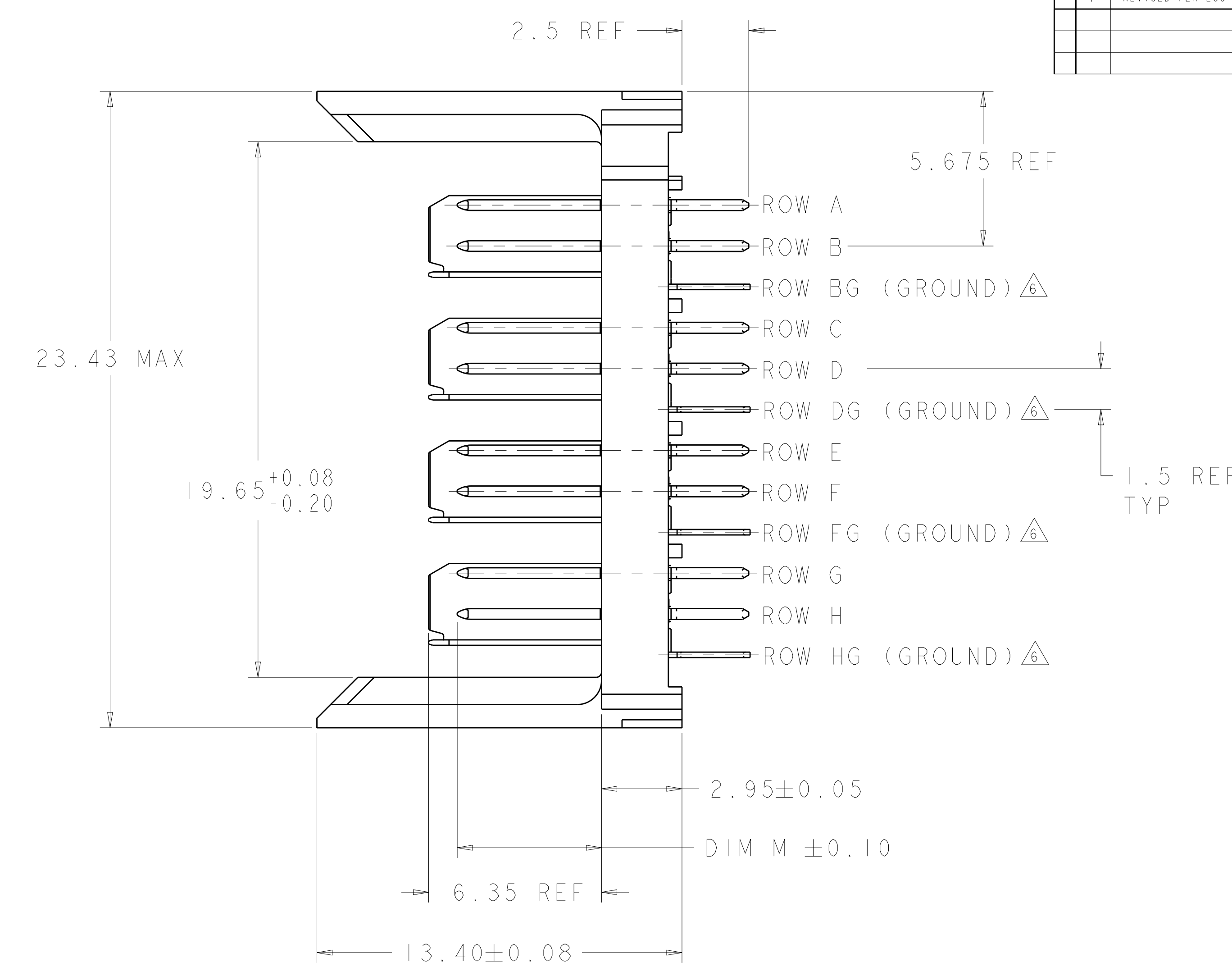
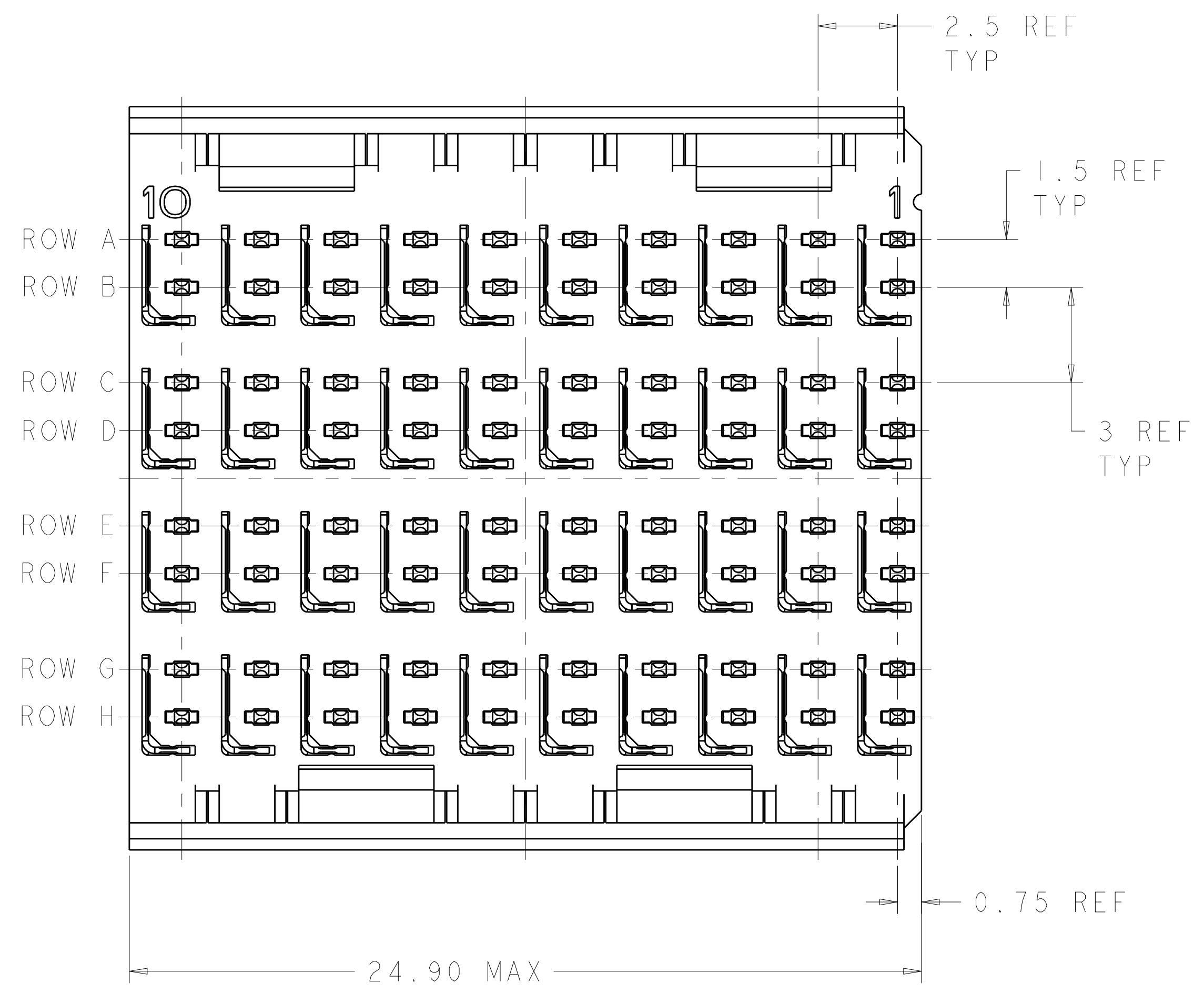

- ⚠ REFERENCE APPLICATION SPEC 114-13059 FOR RECOMMENDED PLATED THRU HOLE DIAMETER AND PLATING THICKNESSES.
- ⚡ MATERIAL:
CONTACT AND SHIELD - PHOSPHOR BRONZE
HOUSING - GLASS FILLED POLYESTER, UL 94V-0.
- ⚡ FINISH: SIGNAL AND GROUND CONTACTS:
MATING AREA: MEETS THE PERFORMANCE REQUIREMENTS OF PRODUCT SPECIFICATION 108-2055; BASED ON TELCORDIA GR-1217-CORE, APPLICATIONS IN UNCONTROLLED ENVIRONMENTS
COMPLIANT PIN AREA: 0.5µm MIN BRIGHT TIN-LEAD OVER BASE PLATING
- ⚡ CONNECTOR MARKED WITH PART NUMBER AND DATE CODE.
- ⚡ DATUMS AND BASIC DIMENSIONS ESTABLISHED BY CUSTOMER.
- ⚡ THE FOUR GROUNDS IN EACH COLUMN ARE COMMONED.
- 7. CONTACT AREA LUBRICATED WITH BELLCORE APPROVED LUBRICANT, TECHNICAL REFERENCE: GR-1217-CORE, ISSUE 1, NOVEMBER 1995.
- ⚡ OBSOLETE

⊕ Ø0.05Ⓢ X Y
 ALL PLATED THRU HOLES

RECOMMENDED PC BOARD LAYOUT, BACKPLANE, COMPONENT SIDE SHOWN
 SCALE 4:1

3.80	⚠ 1469002-2
5.30	1469002-1
DIM M	PART NUMBER

THIS DRAWING IS A CONTROLLED DOCUMENT.		DWN R. KOEGEL 15FEB2001	TE Connectivity NAME HEADER ASSEMBLY, 4 PAIR, 2.5mm TAIL, 25mm HMZd
DIMENSIONS: mm		CHK R. PATTERSON 16AUG2007	
TOLERANCES UNLESS OTHERWISE SPECIFIED:		APVD N. SCHROLL 02MAY01	PRODUCT SPEC
0 PLC ± 1 PLC ± 2 PLC ± 3 PLC ± 4 PLC ± ANGLES ±		APPLICATION SPEC	SIZE A100779
MATERIAL		WEIGHT	RESTRICTED TO
FINISH		Customer Drawing	SCALE 3:1 SHEET 1 OF 1 REV F