



Chipsmall Limited consists of a professional team with an average of over 10 year of expertise in the distribution of electronic components. Based in Hongkong, we have already established firm and mutual-benefit business relationships with customers from,Europe,America and south Asia,supplying obsolete and hard-to-find components to meet their specific needs.

With the principle of "Quality Parts,Customers Priority,Honest Operation,and Considerate Service",our business mainly focus on the distribution of electronic components. Line cards we deal with include Microchip,ALPS,ROHM,Xilinx,Pulse,ON,Everlight and Freescale. Main products comprise IC,Modules,Potentiometer,IC Socket,Relay,Connector.Our parts cover such applications as commercial,industrial, and automotives areas.

We are looking forward to setting up business relationship with you and hope to provide you with the best service and solution. Let us make a better world for our industry!



Contact us

Tel: +86-755-8981 8866 Fax: +86-755-8427 6832

Email & Skype: info@chipsmall.com Web: www.chipsmall.com

Address: A1208, Overseas Decoration Building, #122 Zhenhua RD., Futian, Shenzhen, China



TERMSERIES TRS 24VDC 1NO HC

Weidmüller Interface GmbH & Co. KG

Klingenbergstraße 16

D-32758 Detmold

Germany

Fon: +49 5231 14-0

Fax: +49 5231 14-292083

www.weidmueller.com

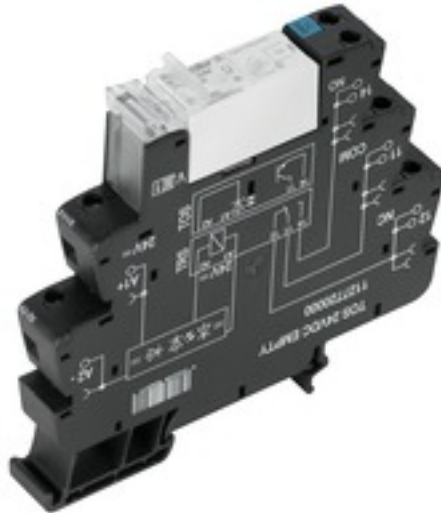

TERMSERIES relay module, complete modules consisting of

a relay and a base with AC/DC/UC coils, available in different versions:

- With screw and tension-clamp connection
- Optionally with multiple-voltage input: 24...230 V UC
- With various protective circuits in the input (free-wheel diode, RC element)
- Illuminated ejection lever

General ordering data

Type	TRS 24VDC 1NO HC
Order No.	1479780000
Version	TERMSERIES, Relay module, No. of contacts: 1 NO contact AgSnO, Rated control voltage: 24 V DC $\pm 20\%$, Continuous current: 16 A, Screw connection
GTIN (EAN)	4050118288100
Qty.	10 pc(s).

TERMSERIES
TRS 24VDC 1NO HC

Weidmüller Interface GmbH & Co. KG
 Klingenbergstraße 16
 D-32758 Detmold
 Germany
 Fon: +49 5231 14-0
 Fax: +49 5231 14-292083
 www.weidmueller.com

Technical data**Dimensions and weights**

Width	12.8 mm	Width (inches)	0.504 inch
Height	89.6 mm	Height (inches)	3.528 inch
Depth	87.8 mm	Depth (inches)	3.457 inch
Net weight	56 g		

Temperatures

Humidity	5–95% rel. humidity, $T_u = 40^\circ\text{C}$, no condensation	Operating temperature, max.	60 °C
Operating temperature, min.	-40 °C	Storage temperature, max.	85 °C
Storage temperature, min.	-40 °C	Operating temperature	-40 °C...60 °C
Storage temperature	-40 °C...85 °C		

Input

Rated control voltage	24 V DC \pm 20 %	Rated current DC	21 mA
Power rating	530 mW	Pull-in/drop-out voltage, typ.	18 V / 4 V DC
Pull-in/drop-out current, typ.	15.5 mA / 2.8 mA DC	Status indicator	Green LED
Protective circuit	Free-wheel diode, Reverse polarity protection	Coil voltage of the replacement relay deviating from the rated control voltage	No
Coil voltage of the replacement relay	24 V DC		

Output

Rated switching voltage	250 V AC	Max. switching voltage, AC	250 V
Max. switching voltage, DC	250 V	Continuous current	16 A
Inrush current	80 A / 20 ms	AC switching capacity (resistive), max.	4000 VA
DC switching capacity (resistive), max.	384 W @ 24 V	Switch-on delay	\leq 7 ms
Switch-off delay	\leq 16 ms	Min. switching power	1 W
Max. switching frequency at rated load	0.1 Hz		

Contact data

Contact type	1 NO contact (AgSnO)	Mechanical service life	10 x 10 ⁶ switching cycles
--------------	----------------------	-------------------------	---------------------------------------

General data

Mounting rail	TS 35	Test button	No
Mechanical switch position indicator	No	Colour	Black
UL 94 flammability rating	V-0		

Insulation coordination

Rated voltage	300 V	Surge voltage category	III
Pollution severity	2	Protection degree	IP20
Dielectric strength input – output	1.2 kV _{eff} / 5 s	Creepage and clearance distance input – output	\geq 5.5 mm
Dielectric strength of open contact	1.2 kV _{eff} / 1 min.	Dielectric strength to mounting rail	4 kV _{eff} / 1 min.
Impulse withstand voltage	6 kV (1.2/50 μ s)		

Further details of approvals / standards

Standards	EN 50178, EN 55011, EN 61000-6-1, 2, 4	Certificate No. (DNVGL)	TAA00001E5
Certificate no. (cULus)	E141197		

Creation date July 2, 2018 4:37:23 PM CEST

TERMSERIES
TRS 24VDC 1NO HC

Weidmüller Interface GmbH & Co. KG
 Klingenbergstraße 16
 D-32758 Detmold
 Germany
 Fon: +49 5231 14-0
 Fax: +49 5231 14-292083
 www.weidmueller.com

Technical data**Connection data**

Wire connection method	Screw connection	Stripping length, rated connection	8 mm
Tightening torque, max.	0.4 Nm	Clamping range, rated connection	1.5 mm ²
Clamping range, min.	0.14 mm ²	Clamping range, max.	2.5 mm ²
Wire connection cross section AWG, min.	AWG 26	Wire connection cross section AWG, max.	AWG 14
Wire cross-section, solid, min.	0.14 mm ²	Wire cross-section, solid, max.	2.5 mm ²
Wire connection cross-section, finely stranded, min.	0.14 mm ²	Wire connection cross section, finely stranded, max.	2.5 mm ²
Wire cross-section, finely stranded, min. (AWG)	AWG 26	Wire cross-section, finely stranded, max. (AWG)	AWG 14
Wire connection cross-section, finely stranded with wire-end ferrules DIN 46228/4, min.	0.25 mm ²	Wire connection cross-section, finely stranded with wire-end ferrules DIN 46228/4, max.	2.5 mm ²
Conductor cross-section, flexible, AEH (DIN 46228-1), min.	0.25 mm ²	Conductor cross-section, flexible, AEH (DIN 46228-1), max.	2.5 mm ²
Wire connection cross section, finely stranded, two clampable wires, min.	0.5 mm ²	Wire cross-section, finely stranded, two clampable wires, max.	1 mm ²
Twin wire-end ferrules, min.	0.5 mm ²	Twin wire-end ferrules, max.	1 mm ²
Blade size	size PH0	Gauge to IEC 60947-1	A1, B1

Rated data UL

Ambient temperature (operational), max. 60 °C	Connection cross-section AWG, min.	AWG 26	
Connection cross-section AWG, max.	Type of conductor	rigid copper conductor, flexible copper conductor	
Tightening torque, max.	0.4 Nm	Pollution severity level	2

Classifications

ETIM 5.0	EC001437	ETIM 6.0	EC001437
eClass 6.2	27-37-16-01	eClass 7.1	27-37-16-01
eClass 8.1	27-37-16-01	eClass 9.0	27-37-16-01
eClass 9.1	27-37-16-01		

Approvals

Approvals



ROHS

Conform

Downloads

Approval/Certificate/Document of Conformity	DE_PA5600_160229_001.pdf
Brochure/Catalogue	CAT 4.2 ELECTR 18/19 EN
Engineering Data	EPLAN, WSCAD, Zuken E3.S
Engineering Data	STEP
User Documentation	Operating Instructions

Data sheet

**TERMSERIES
TRS 24VDC 1NO HC**

Weidmüller Interface GmbH & Co. KG
 Klingenbergstraße 16
 D-32758 Detmold
 Germany
 Fon: +49 5231 14-0
 Fax: +49 5231 14-292083
 www.weidmueller.com

Drawings

Wiring diagram

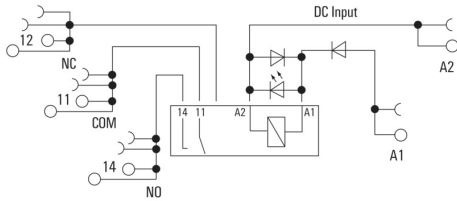

Graph

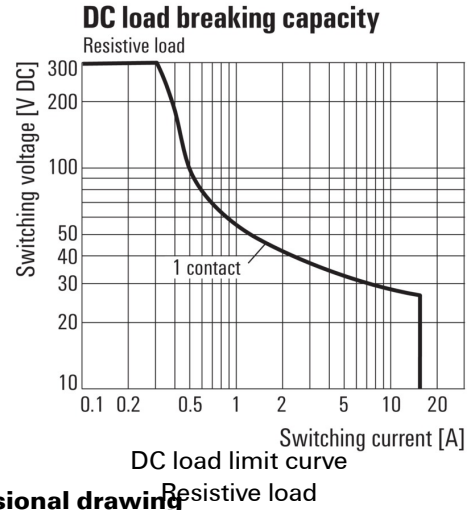

Dimensional drawing

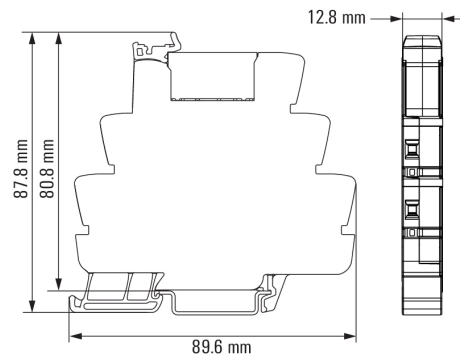

**TERMSERIES
TRS 24VDC 1NO HC**

Weidmüller Interface GmbH & Co. KG
 Klingenbergstraße 16
 D-32758 Detmold
 Germany
 Fon: +49 5231 14-0
 Fax: +49 5231 14-292083
 www.weidmueller.com

Drawings

Miscellaneous

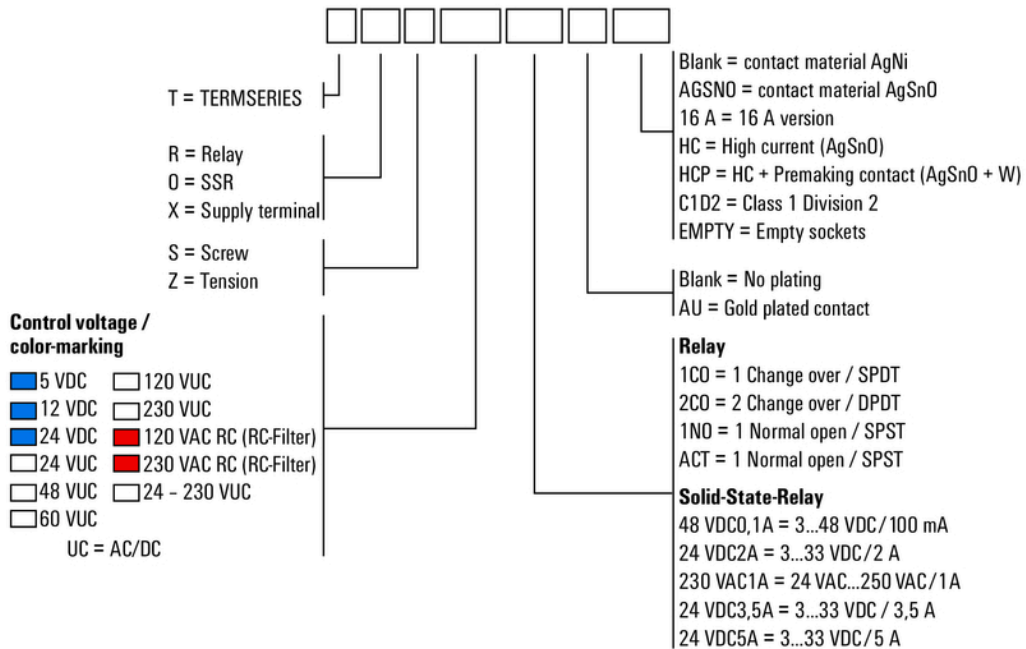

Type codes