



Chipsmall Limited consists of a professional team with an average of over 10 year of expertise in the distribution of electronic components. Based in Hongkong, we have already established firm and mutual-benefit business relationships with customers from,Europe,America and south Asia,supplying obsolete and hard-to-find components to meet their specific needs.

With the principle of “Quality Parts,Customers Priority,Honest Operation,and Considerate Service”,our business mainly focus on the distribution of electronic components. Line cards we deal with include Microchip,ALPS,ROHM,Xilinx,Pulse,ON,Everlight and Freescale. Main products comprise IC,Modules,Potentiometer,IC Socket,Relay,Connector.Our parts cover such applications as commercial,industrial, and automotives areas.

We are looking forward to setting up business relationship with you and hope to provide you with the best service and solution. Let us make a better world for our industry!



Contact us

Tel: +86-755-8981 8866 Fax: +86-755-8427 6832

Email & Skype: info@chipsmall.com Web: www.chipsmall.com

Address: A1208, Overseas Decoration Building, #122 Zhenhua RD., Futian, Shenzhen, China



MODEL NO.	PACKAGING
148-0801-301	ONE PCS PER BAG

REV	ECO	DATE
001	ECO-17-0003	12/18/2017

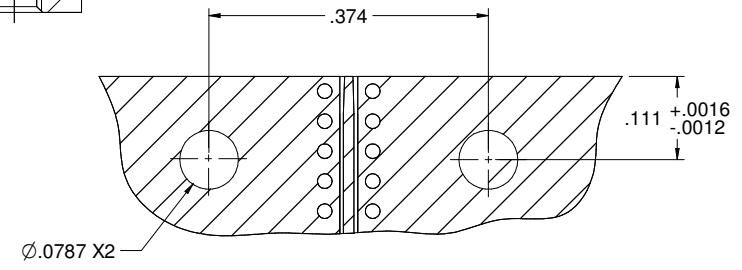
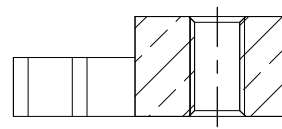
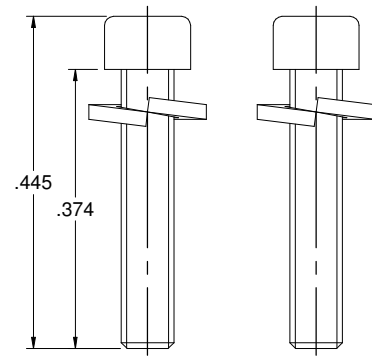
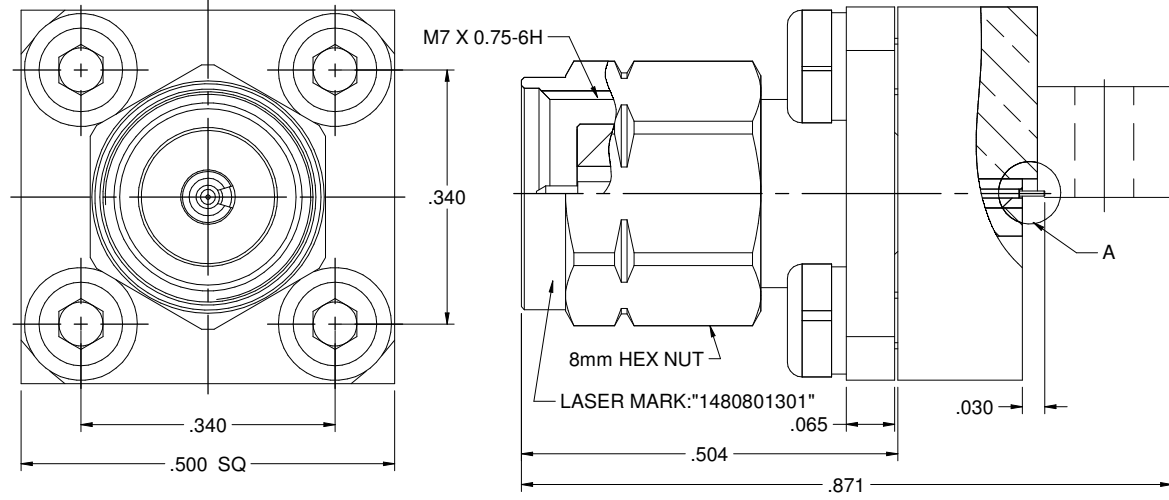
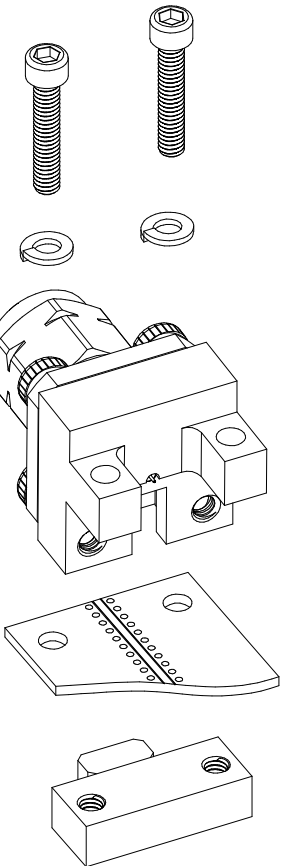
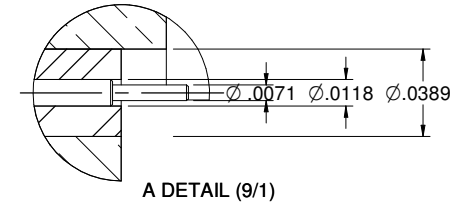

PCB LAYOUT

NOTES: UNLESS OTHERWISE SPECIFIED

1. MATERIAL & FINISH:
 - 1.1 BODY: NICKEL PLATED BRASS
 - 1.2 CONTACT PIN : GOLD PLATED BERYLLIUM COPPER
 - 1.3 INSULATOR: PTFE WHITE
 - 1.4 BOLT & WASHER: STAINLESS STEEL
2. ELECTRICAL:
 - 2.1 IMPEDANCE: 50 OHMS
 - 2.2 FREQUENCY RANGE: 0-67 GHz
 - 2.3 VOLTAGE STANDING WAVE RATIO: 1.2 MAX
 - 2.4 CONTACT RESISTANCE:
 - 2.4.1 CENTER CONTACT: 6 MILLIOHM MAX
 - 2.4.2 OUTER CONTACT: 2.5 MILLIOHM MAX
 - 2.5 INSULATION RESISTANCE: 5000 MOHM MIN
 - 2.6 DIELECTRIC WITHSTANDING VOLTAGE: 500 VRMS
3. MECHANICAL:
 - 3.1 ENGAGEMENT/DISENGAGEMENT FORCE: 0.23 NM MAX
 - 3.2 COUPLING PROOF TORQUE: 1.65NM MIN
 - 3.3 COUPLING NUT RETENTION: 267 N MIN
 - 3.4 CONTACT RETENTION: 20N MIN
 - 3.5 DURABILITY: 500 CYCLES MIN
4. ENVIRONMENT:
 - 4.1 THERMAL SHOCK: MIL-STD-202, METHOD 107, CONDITION B.
 - 4.2 OPERATING TEMPERATURE: -55 TO 125 °C
 - 4.3 SALT SPRAY: MIL-STD-202, METHOD 101, CONDITION B
 - 4.4 SHOCK: MIL-STD-202, METHOD 213, CONDITION I
 - 4.5 VIBRATION: MIL-STD-202, METHOD 204, CONDITION D
 - 4.6 MOISTURE RESISTANCE: MIL-STD-202, METHOD 106

	Model No. 148-0801-301/310	Johnson	
	RoHS2 2011/65/EU REACH 2002/61/EC ANGLE 45°	Title: END LAUNCH PLUG, SCREW-ON TYPE: 1.85mm Drawing No. 148-0801-301/310	Rev. 001