



Chipsmall Limited consists of a professional team with an average of over 10 year of expertise in the distribution of electronic components. Based in Hongkong, we have already established firm and mutual-benefit business relationships with customers from,Europe,America and south Asia,supplying obsolete and hard-to-find components to meet their specific needs.

With the principle of "Quality Parts,Customers Priority,Honest Operation,and Considerate Service",our business mainly focus on the distribution of electronic components. Line cards we deal with include Microchip,ALPS,ROHM,Xilinx,Pulse,ON,Everlight and Freescale. Main products comprise IC,Modules,Potentiometer,IC Socket,Relay,Connector.Our parts cover such applications as commercial,industrial, and automotives areas.

We are looking forward to setting up business relationship with you and hope to provide you with the best service and solution. Let us make a better world for our industry!



Contact us

Tel: +86-755-8981 8866 Fax: +86-755-8427 6832

Email & Skype: info@chipsmall.com Web: www.chipsmall.com

Address: A1208, Overseas Decoration Building, #122 Zhenhua RD., Futian, Shenzhen, China



NOTES:

1. FOR WAVESOLDERING (SOLDER BATH TEMPERATURE 265°C FOR 8 SEC. AND SOLDER PREHEAT 150°C FOR 180 SEC.)
2. IP RATING: IP 67
3. SEALED TO WITHSTAND PRESSURE UP TO 1,45 PSI FOR 30 MINUTES AFTER HIGH TEMPERATURE EXPOSURE
4. METAL SHELL:
 - ZINC DIE CAST; min. 50µin NICKEL PLATING over COPPER
5. INSULATORS: PBT GF UL 94 V-0, BLACK
6. O-RING: SILICONE PER ASTM D2000 70 SHORE A
7. RUBBER GASKET: TPE
8. SEALING COMPOUND: EPOXY RESIN UL 94 V-0; BLACK
9. CONTACTS: COPPER ALLOY PLATING (SEE PART NO):
 - PLEASE ADD 1 for 30µin HARD GOLD over min. 50µin NICKEL
 - PLEASE ADD 3 for 8µin HARD GOLD over min. 50µin NICKEL
10. METAL BRACKETS: ZINC DIE CAST; 300µin COPPER/40-120µin NICKEL/120-200µin TIN
11. WASHERS: COPPER ALLOY; 80µin NICKEL
12. HEXLOCKING SCREWS: STAINLESS STEEL
13. PCB-SNAPS: COPPER ALLOY; min. 200µin TIN over 80µin NICKEL PCB-HOLE: $\varnothing 3.1 \pm 0.1$; PCB THICKNESS 1.6mm
14. P.C.B. HOLE DRILLINGS and RECOMMENDED PANEL CUT-OUT ON SHEET 2
15. RECOMMENDED TORQUE FOR MOUNTING SCREW 35Ncm (3.1 in.LB) / max.67Ncm (6 in.LB)
16. CONNECTOR IS PART MARKED: 15-00073 CONEC ABC

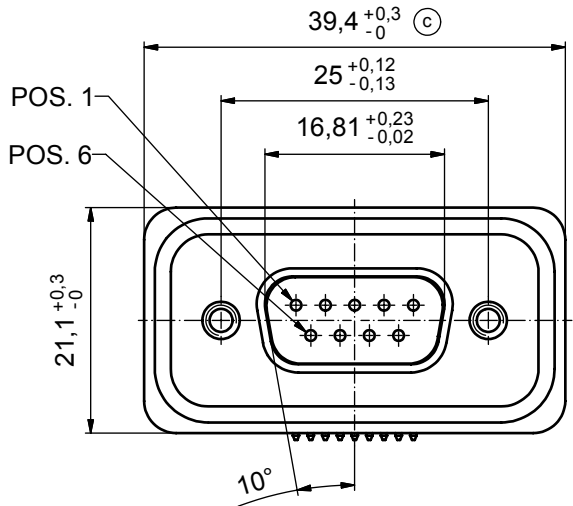
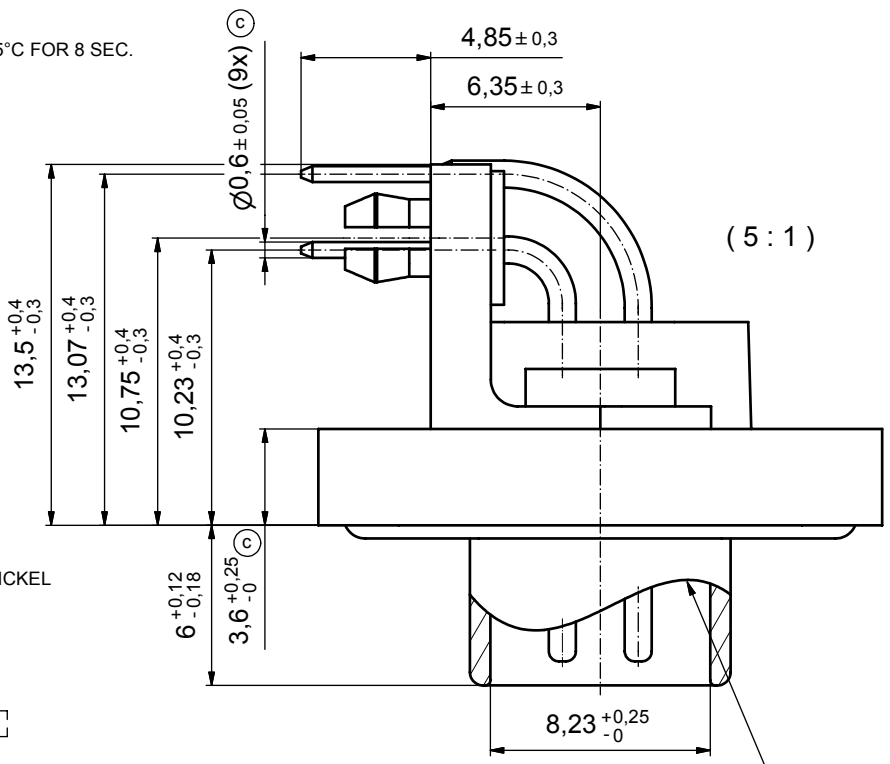

RUBBER GASKET PLACED ON TOP SURFACE OF MALE INSULATOR

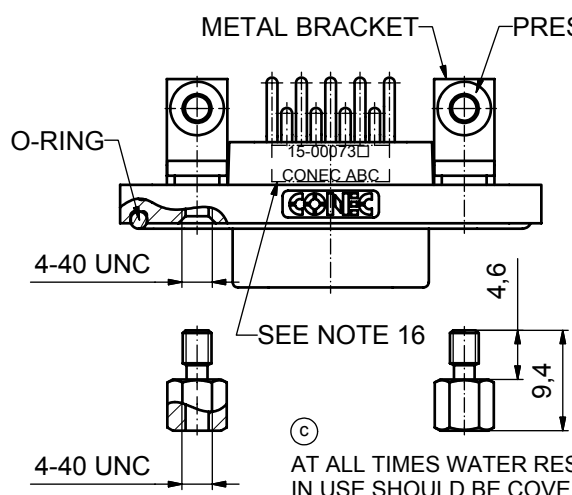
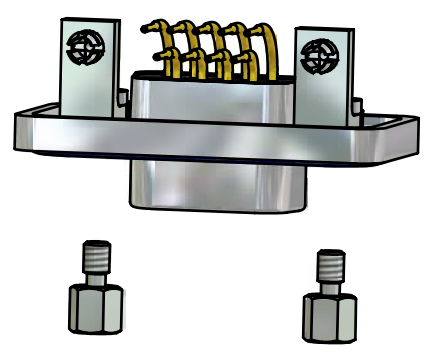

AT ALL TIMES WATER RESISTANT CONNECTORS NOT IN USE SHOULD BE COVERED WITH A CONEC WATER RESISTANT CAP OR WATER TIGHT HOOD.

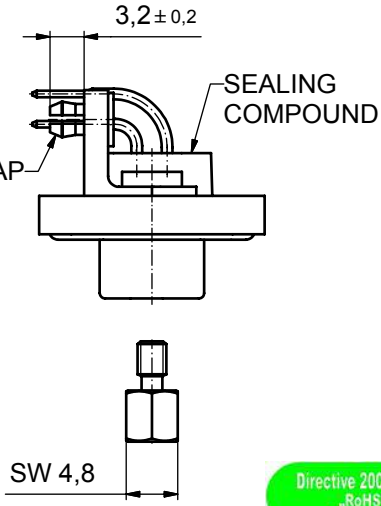

Directive 2002/95/EC
„RoHS“
Compliant

APPROVAL # FREIGABE # DEBLOCAGE # AUTORIZACION # APPROVAL	APPROVAL # FREIGABE # DEBLOCAGE # AUTORIZACION # APPROVAL
CUSTOMER APPROVAL DATE:	
NAME:	TITLE:
COMPANY NAME:	
APPROVAL # FREIGABE # DEBLOCAGE # AUTORIZACION # APPROVAL	APPROVAL # FREIGABE # DEBLOCAGE # AUTORIZACION # APPROVAL

THIS DRAWING MAY NOT BE COPIED OR REPRODUCED IN ANY WAY, AND MAY NOT BE PASSED ON TO A THIRD PARTY WITHOUT WRITTEN PERMISSION. OWNERSHIP AND COPYRIGHT OF CONEC GmbH DO NOT ALTER CAD DRAWING BY HAND				tolerance		scale: 2:1 (5:1)		
date				dim. in mm		material: see notes		
name				title: D-SUB MALE 90° 9pos. SOLDER PIN ANGLED with metal bracket, hexlocking screw and snap		dwg no: Inventor 10		
drawn 17.10.08							DIN-A3	
appd. 23.10.08								
norm				part no: 15K1A282		(see note 9)		
d-old							CONEC	
4 x c	A 3435	02.10.09	HS					
a	Origin							
rev.	description	date	name					

dwg no: Inventor 10	DIN-A3
sh: 1	part no: 15K1A282
(see note 9)	

