



Chipsmall Limited consists of a professional team with an average of over 10 year of expertise in the distribution of electronic components. Based in Hongkong, we have already established firm and mutual-benefit business relationships with customers from,Europe,America and south Asia,supplying obsolete and hard-to-find components to meet their specific needs.

With the principle of "Quality Parts,Customers Priority,Honest Operation,and Considerate Service",our business mainly focus on the distribution of electronic components. Line cards we deal with include Microchip,ALPS,ROHM,Xilinx,Pulse,ON,Everlight and Freescale. Main products comprise IC,Modules,Potentiometer,IC Socket,Relay,Connector.Our parts cover such applications as commercial,industrial, and automotives areas.

We are looking forward to setting up business relationship with you and hope to provide you with the best service and solution. Let us make a better world for our industry!



Contact us

Tel: +86-755-8981 8866 Fax: +86-755-8427 6832

Email & Skype: info@chipsmall.com Web: www.chipsmall.com

Address: A1208, Overseas Decoration Building, #122 Zhenhua RD., Futian, Shenzhen, China



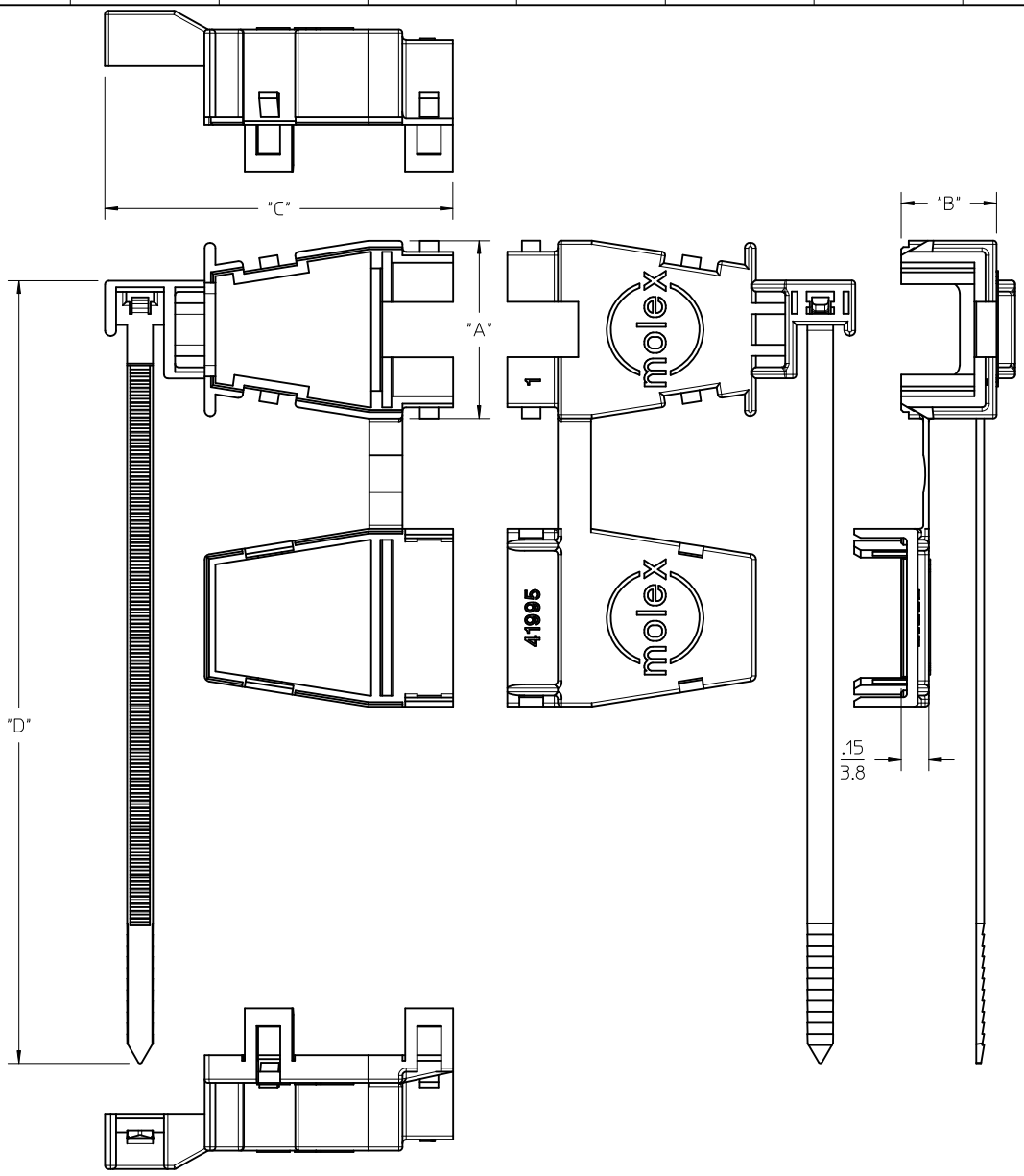
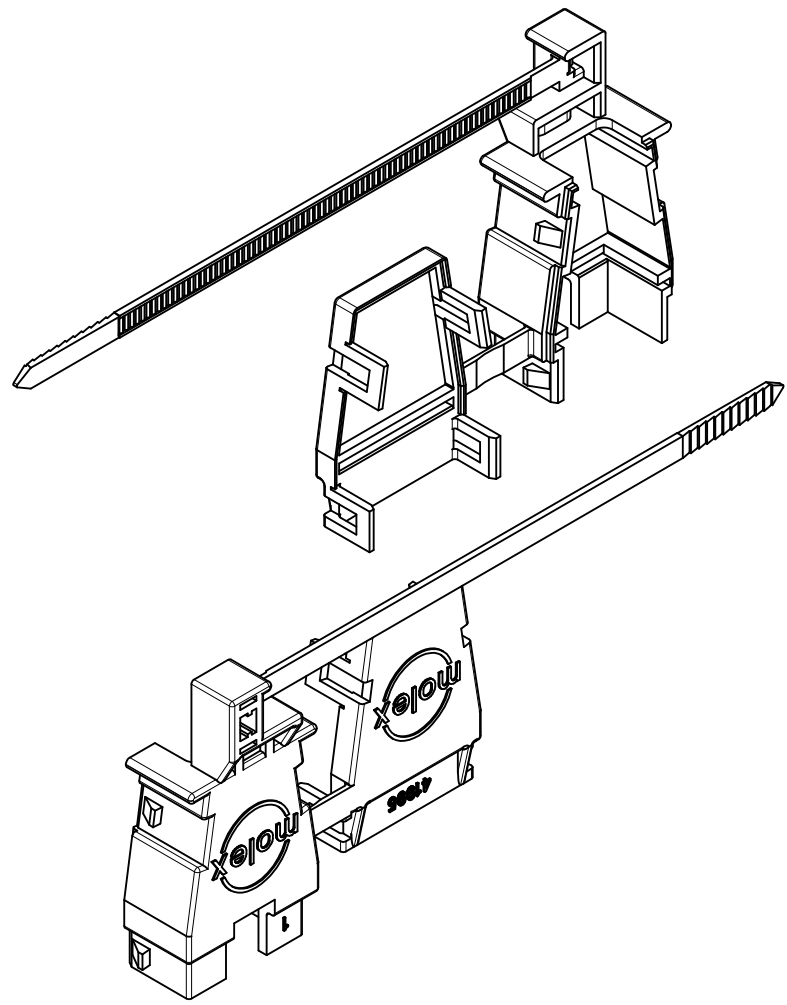

1. MATERIAL: NYLON 6/6 UL94V-2.
COLOR: SEE LEGEND (SHEET 2).
2. FINISH: NOT APPLICABLE
3. PRODUCT SPECIFICATION: PS-41995-001
4. PACKAGING: PK-41995-001.
5. THIS PART IS TO BE USED ONLY WITH MINI-FIT JR. SERIES CONNECTORS WITHOUT MOUNTING EARS, PER CHART. SEE SHEET 2.
6. THIS PART CAN BE USED WITH A STANDARD TIE-STRAP GUN.
7. ALL DIMENSIONS ARE FOR REFERENCE ONLY.
8. PART CONFORMS TO CLASS "B" REQUIREMENTS OF COSMETIC SPECIFICATION PS-45499-002.
9. IF THIS PRODUCT IS STORED IN AN ENVIRONMENT WITH A RELATIVE HUMIDITY OF LESS THAN 50%, MOISTURE MUST BE ADDED. REFER TO TECHNICAL ADVISORY AS-45499-001 FOR INSTRUCTIONS.

REMOVE 20K ADD 8 CKT EC NO: UCP2011-1341 DRWN: JAGUILAR CHKD: JELL APPR: FSMITH	2010/11/09 2010/11/09 2010/12/09	QUALITY SYMBOLS ▽=0 ▽=0 ▽=0	GENERAL TOLERANCES (UNLESS SPECIFIED)		DIMENSION STYLE IN/MM		SCALE 2:1	DESIGN UNITS METRIC	THIRD ANGLE PROJECTION		
			mm INCH	DRAWN BY DMF	DATE 1989/05/01	STRAIN RELIEF FOR MINI-FIT PLUGS AND RECEPTACLES					
			4 PLACES ± --- ± --- 3 PLACES ± --- ± --- 2 PLACES ± --- ± --- 1 PLACE ± --- ± ---	CHECKED BY RHR	DATE 1989/05/01						
			ANGULAR ±1/2°	APPROVED BY FSMITH	DATE 2010/12/09	MOLEX INCORPORATED		DOCUMENT NO. SD-41995-***		SHEET NO. 1 OF 2	
DRAFT WHERE APPLICABLE MUST REMAIN WITHIN DIMENSIONS			SEE CHART		THIS DRAWING CONTAINS INFORMATION THAT IS PROPRIETARY TO MOLEX INCORPORATED AND SHOULD NOT BE USED WITHOUT WRITTEN PERMISSION						

PART NO.	ENG. NO.	FOR USE WITH CONNECTOR NO.	CKT. SIZE	DIM. "A"	DIM. "B"	DIM. "C"	DIM. "D"
15-04-0296	41995-6AA	5557-06R* 5559-06P1*	6	.80/20.3	.52/13.2	1.89/48.0	3.25/82.55
15-04-0343	41995-8AA	5557-08R* 5559-08P1*	8	.97/24.6	.52/13.2	1.89/48.0	4.25/107.9
15-04-9342	41995-6AB	5557-06R* 5559-06P1*	6	.80/20.3	.52/13.2	1.89/48.0	3.25/82.55
15-04-9343	41995-8AB	5557-08R* 5559-08P1*	8	.97/24.6	.52/13.2	1.89/48.0	4.25/107.9

LEGEND: 41995-***

BASE NUMBER _____

CIRCUIT SIZE _____
(2-22)

MATERIAL _____
A NYLON 6/6, U.L. 94V-2

COLOR _____
A = NATURAL (WHITE)
B = BLACK

SEE SHEET 1 EC NO: UCP2011-1341 DRWN: JAGUILAR 2010/11/09 CHKD: BELL 2010/11/09 APPR: FSMITH 2010/12/09	QUALITY SYMBOLS	GENERAL TOLERANCES (UNLESS SPECIFIED)	DIMENSION STYLE	SCALE	DESIGN UNITS	THIRD ANGLE PROJECTION
	▽=0	mm INCH	IN/MM	1:1	METRIC	☉
	▽=0	4 PLACES ± --- ± ---	DRAWN BY DATE	TITLE		
	▽=0	3 PLACES ± --- ± ---	DMF 1989/05/01	STRAIN RELIEF FOR MINI-FIT PLUGS AND RECEPTACLES		
▽=0	2 PLACES ± --- ± ---	CHECKED BY DATE	MATERIAL NO. DOCUMENT NO.			
▽=0	1 PLACE ± --- ± ---	RHR 1989/05/01	SD-41995-***			
	ANGULAR ±1/2°	APPROVED BY DATE	SHEET NO.			
		FSMITH 2010/12/09	2 OF 2			
		DRAFT WHERE APPLICABLE MUST REMAIN WITHIN DIMENSIONS		THIS DRAWING CONTAINS INFORMATION THAT IS PROPRIETARY TO MOLEX INCORPORATED AND SHOULD NOT BE USED WITHOUT WRITTEN PERMISSION		