



Chipsmall Limited consists of a professional team with an average of over 10 year of expertise in the distribution of electronic components. Based in Hongkong, we have already established firm and mutual-benefit business relationships with customers from,Europe,America and south Asia,supplying obsolete and hard-to-find components to meet their specific needs.

With the principle of “Quality Parts,Customers Priority,Honest Operation,and Considerate Service”,our business mainly focus on the distribution of electronic components. Line cards we deal with include Microchip,ALPS,ROHM,Xilinx,Pulse,ON,Everlight and Freescale. Main products comprise IC,Modules,Potentiometer,IC Socket,Relay,Connector.Our parts cover such applications as commercial,industrial, and automotives areas.

We are looking forward to setting up business relationship with you and hope to provide you with the best service and solution. Let us make a better world for our industry!



Contact us

Tel: +86-755-8981 8866 Fax: +86-755-8427 6832

Email & Skype: info@chipsmall.com Web: www.chipsmall.com

Address: A1208, Overseas Decoration Building, #122 Zhenhua RD., Futian, Shenzhen, China



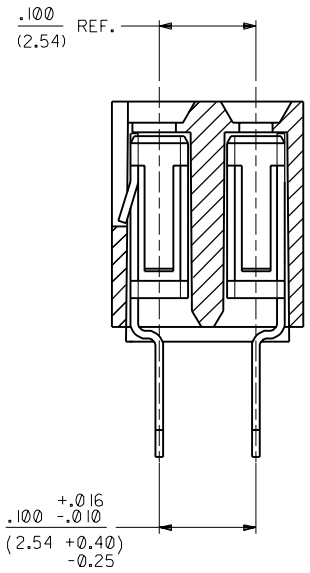
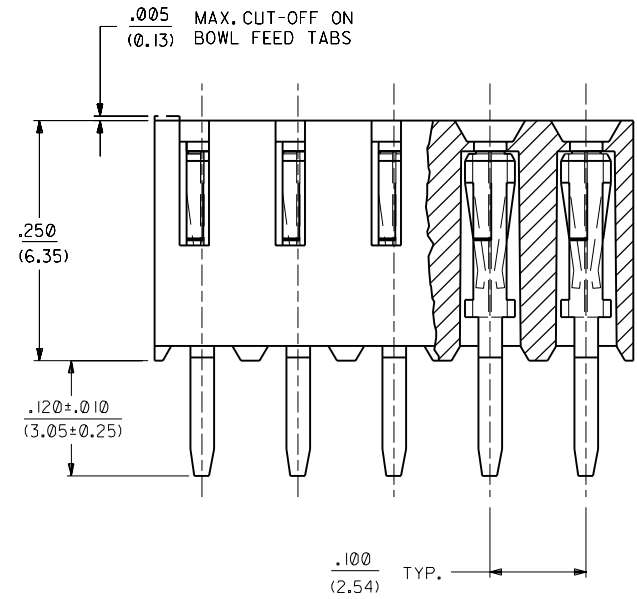
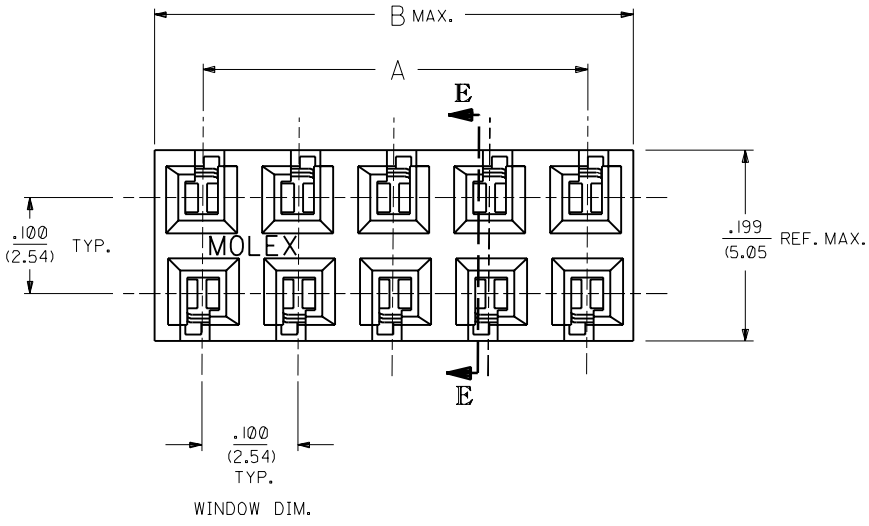

- NOTES:
- 1 - HOUSING MATERIAL: GLASS FILLED POLYESTER, UL 94V-0. COLOR: BLACK
 - 2 - TERMINAL MATERIAL: PHOSPHOR BRONZE
 - 3 - SEE ADDITIONAL SHEETS FOR CHARTS, PLATINGS, AND OVERALL DIMENSIONS
 - 4 - THIS PRODUCT CONFORMS TO PS-70181.

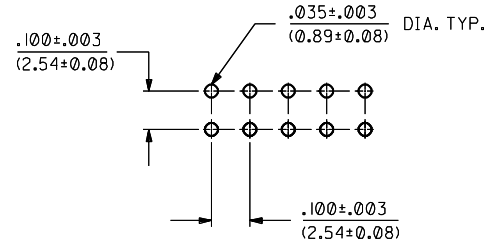

RECOMMENDED P.C. BOARD HOLE LAYOUT
SCALE = 4:1

B	CHANGE PACK SPEC. ECN# UDT2000-0503 DMORGAN 99/12/14		
A	REVISE PLATE & BOX REL. DWG U30572 09/08/93 MURPHY		
2	B		
1	B		
MFG. SH.	REV.	LTR.	REVISIONS

DIMENSIONS SHOWN (METRIC) INCH
UNLESS OTHERWISE SPECIFIED TOLERANCES ANGULAR ± 1/2°

3 PLACE	± .010	---
2 PLACE	± .014	± 0.25
1 PLACE	---	± 0.35

DRAFT WHERE APPLICABLE MUST REMAIN WITHIN DIMENSIONS

DRWG. BY: PM CHK'D. BY: PM
APP'D. BY: PM SCALE: 10:1

FILE NAME: S70182X1.DWG
MOLX INC. AND SHOULD NOT BE USED WITHOUT WRITTEN PERMISSION.

TITLE: CONNECTOR, VERT. MOUNT DUAL ROW TOP ENTRY .100 X .100 PC TAIL GRID

MOLEX INCORPORATED U.S.A. L15LE,ILL. 60532

PART NO. SDA-70182-****
DRWG. NO. 1 OF 2
SHEET NO. 1 OF 2
DATE 09/08/93

REVISIONS: REVISE ONLY ON CAD SYSTEM

