



Chipsmall Limited consists of a professional team with an average of over 10 year of expertise in the distribution of electronic components. Based in Hongkong, we have already established firm and mutual-benefit business relationships with customers from,Europe,America and south Asia,supplying obsolete and hard-to-find components to meet their specific needs.

With the principle of “Quality Parts,Customers Priority,Honest Operation,and Considerate Service”,our business mainly focus on the distribution of electronic components. Line cards we deal with include Microchip,ALPS,ROHM,Xilinx,Pulse,ON,Everlight and Freescale. Main products comprise IC,Modules,Potentiometer,IC Socket,Relay,Connector.Our parts cover such applications as commercial,industrial, and automotives areas.

We are looking forward to setting up business relationship with you and hope to provide you with the best service and solution. Let us make a better world for our industry!



Contact us

Tel: +86-755-8981 8866 Fax: +86-755-8427 6832

Email & Skype: info@chipsmall.com Web: www.chipsmall.com

Address: A1208, Overseas Decoration Building, #122 Zhenhua RD., Futian, Shenzhen, China

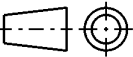
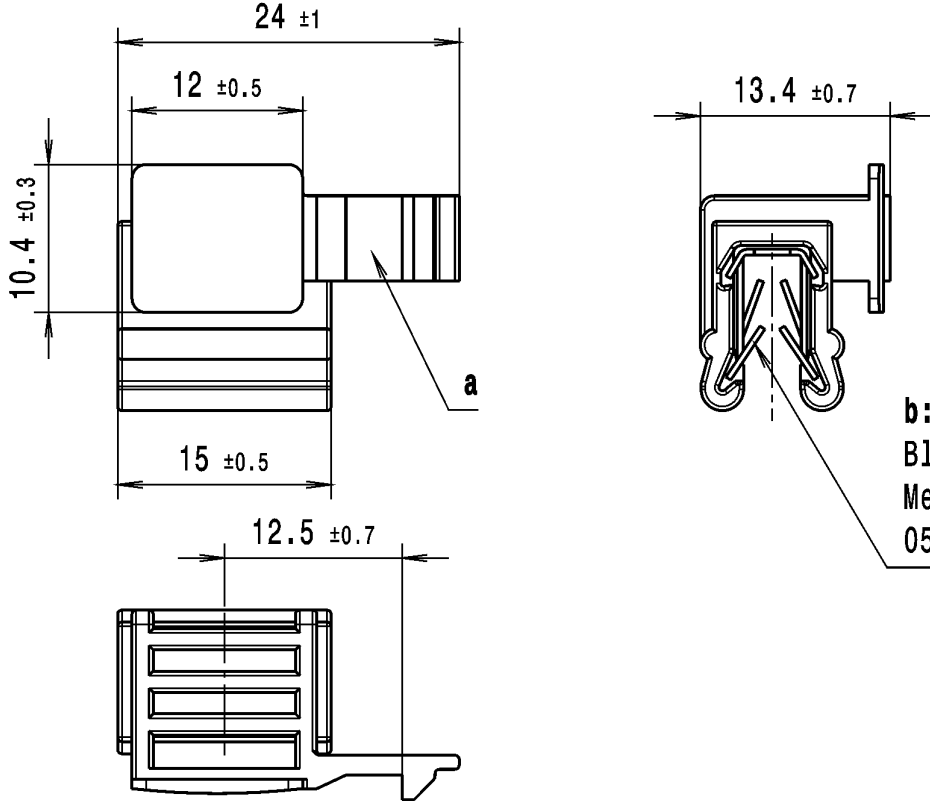
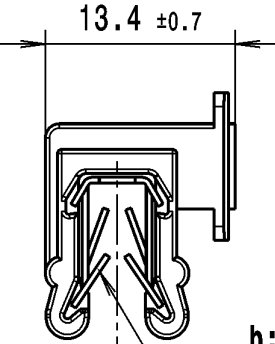
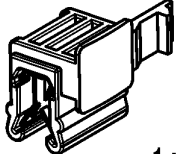

CATIA V5 		Revision level Indice Aenderungsstand		Revision Record Désignation Beschreibung der Aenderung		Changed Modifié Geändert	Date Datum	Approved Approuvé Geprüft	Date Datum
Intended For Welded Screw Ø Pour Goujon Soudé à Filets Couchés Ø Aufnahme fuer Schweissbolzen Ø		Drawing Dessin Zeichnung	Part Pièce Solid						
Tensile Strength Force de Tenue Abbindefestigkeit						<p>Nur zur Information, wird vom Änderungsdienst nicht erfaßt. For information only, not subject to alteration service.</p>			
Hole Size Trou Ø Loch Ø									
Panel Thickness Epaisseur Support Blechdicke 1,5 - 4 mm									
Bundle Ø Toron Ø Buendel Ø									
Material Matière Werkstoff a: PA6.6 hitzestabilisiert, schlagzaeh / PA6.6 heatstabilized, impact resistant						<p>b: Blechklammer beschichtet/ Metal clamp coated 05-056-001-K</p> 			
<p>Tolerances Dimension without tolerances details to:</p> <p>Tolérances Cotes sans tolérances:</p> <p>Toleranzen Masse ohne Toleranzangaben nach: DIN 16901 / 140</p>		<p>The copyright of this drawing is reserved by HELLERMANN TYTON. It is issued on condition that it is not reproduced, copied or disclosed to a third party, either wholly or in part, without the consent of HELLERMANN TYTON.</p> <p>La propriété de ce plan est réservée à la société HELLERMANN TYTON. Il est distribué à condition qu'il ne soit pas reproduit, communiqué ou révélé à une tierce partie, soit complètement ou en partie, sans le consentement de la société HELLERMANN TYTON.</p>		<p>Drawn Dessiné Par Gezeichnet</p> <p>Langeloh</p> <p>30.10.06</p>	<p>Scale Echelle Maszstab</p> <p>2:1; 1:1</p>	<p>Project Number Numéro de projet Projektnummer</p> <p>NT-159-06</p>			
<p>PERFORMANCE SPECIFICATION AUSFUEHRUNG SPEZIFIKATION</p>		<p>Approved Approuvé Par Geprüft</p> <p>Schiwek</p> <p>30.10.06</p>		<p>Title Titre Benennung</p> <p>Edge Clip 43 EC43</p>		<p>Drawing-No Plan-No Zeichnungs-Nr</p> <p>14.1997</p>		<p>Format D.Size</p> <p>A4</p>	
		<p>Manchester Telephone: +44 (0) 161 945 4181 Facsimile: +44 (0) 161 947 2228</p> <p>Trappes Téléphone: +33 (0) 1 30 13 80 00 Télécopie: +33 (0) 1 30 13 80 60</p> <p>Tornesch Telefon: +49 (0) 41 22 / 701 - 1 Telefax: +49 (0) 41 22 / 701 - 400</p>						<p>Sheet Page Blatt</p> <p>1 / 1</p>	