



Chipsmall Limited consists of a professional team with an average of over 10 year of expertise in the distribution of electronic components. Based in Hongkong, we have already established firm and mutual-benefit business relationships with customers from,Europe,America and south Asia,supplying obsolete and hard-to-find components to meet their specific needs.

With the principle of “Quality Parts,Customers Priority,Honest Operation,and Considerate Service”,our business mainly focus on the distribution of electronic components. Line cards we deal with include Microchip,ALPS,ROHM,Xilinx,Pulse,ON,Everlight and Freescale. Main products comprise IC,Modules,Potentiometer,IC Socket,Relay,Connector.Our parts cover such applications as commercial,industrial, and automotives areas.

We are looking forward to setting up business relationship with you and hope to provide you with the best service and solution. Let us make a better world for our industry!



## Contact us

Tel: +86-755-8981 8866 Fax: +86-755-8427 6832

Email & Skype: info@chipsmall.com Web: www.chipsmall.com

Address: A1208, Overseas Decoration Building, #122 Zhenhua RD., Futian, Shenzhen, China



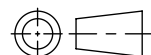

Revision level			Revision Record	Changed	Date	Approved	Date
Drawing	State	Part					
05.1	Design Release	-	SEE ECN# 013543	RLV	11/21/2016	KAC	11/21/2016

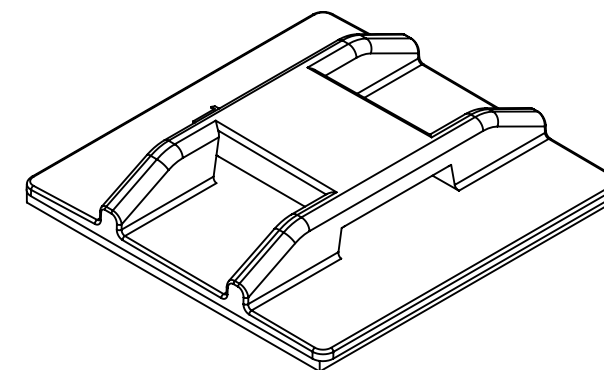
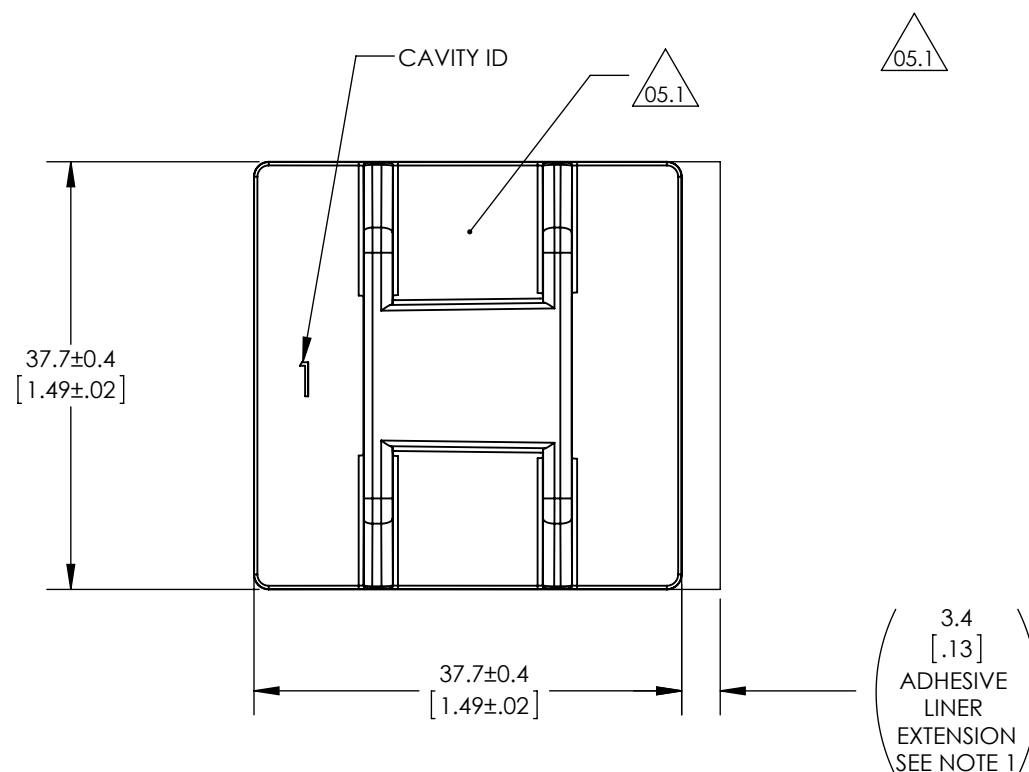

05.1

**INITIAL PERFORMANCE VALIDATION:**  
MOUNT WITH ADHESIVE IS DESIGNED FOR:

- MAX (TBD) LBS PULL OFF PERPENDICULAR TO CLEAN DRY SMOOTH STAINLESS STEEL MOUNTING SURFACE AT 80°C FOR (TBD) DAYS
- MAX (TBD) LBS PULL OFF PARALLEL TO CLEAN DRY SMOOTH STAINLESS STEEL MOUNTING SURFACE AT 80°C FOR (TBD) DAYS
- MAX IN-SERVICE (SURFACE OR AMBIENT) TEMPERATURE OF 80°C FOR (TBD) DAYS

THE CLAIMS EXPRESSED OR IMPLIED HERE WITH RESPECT TO THE ADHESIVE PERFORMANCE ARE SUBJECT TO VARIATION AND ARE BEYOND HELLERMANN TYTON'S CONTROL

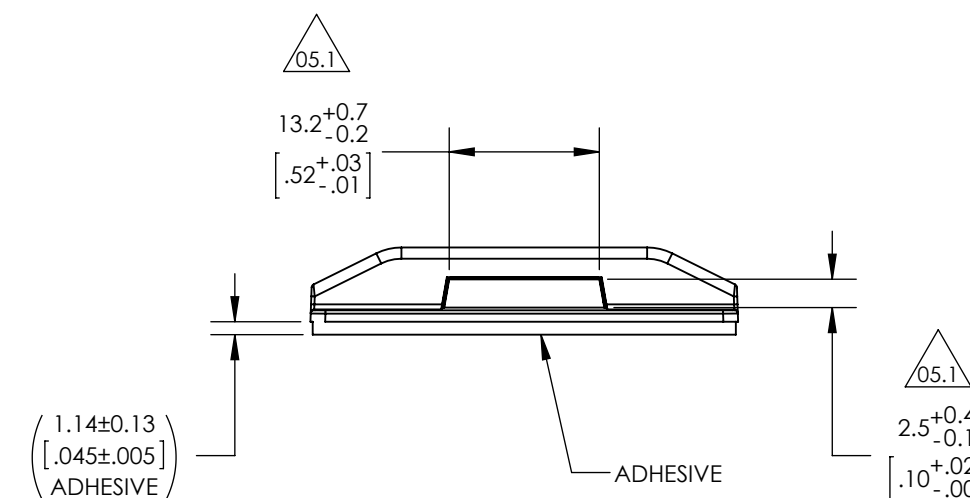
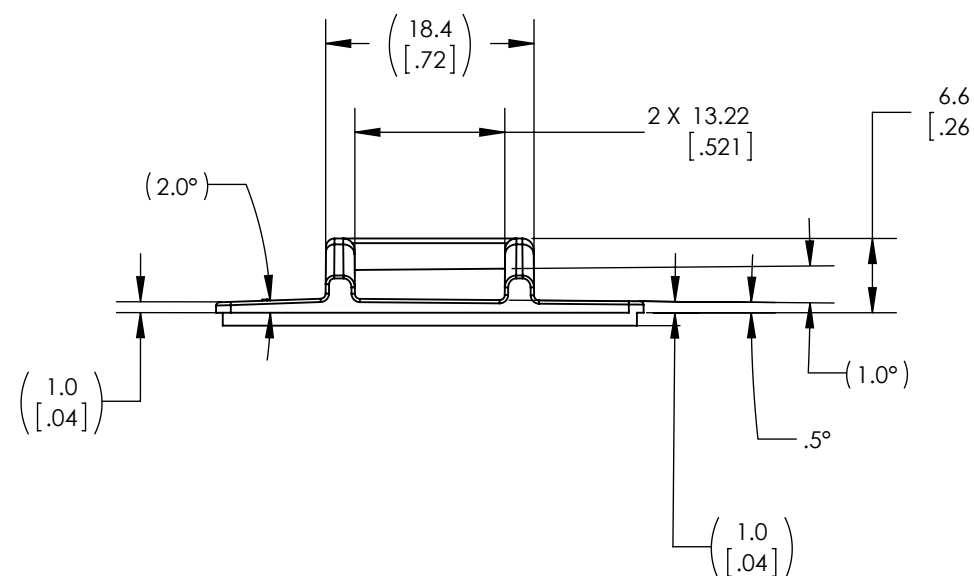

- Notes
1. LINER EXTENSION NOT KEYED TO SPECIFIC SIDE
  2. DESIGNED FOR USE WITH WS TYPE CABLE TIES

05.1

Material  
PA66HIRHSUV BLACK  
ASTM D4066 PA0161  
ASTM D6779 PA0161  
ADHESIVE:  
ACRYLIC FOAM  
PER URAD5PX5011E

Units: millimeters  
Dimension without tolerances details to:  
.xxx = ±.013  
.xx = ±.13  
.x = ±.3  
None = ±.8  
∠ = ±0.5°  
Dimension Formatted mm/[in]

The copyright of this drawing is reserved by Hellermann Tyton. It is issued on condition that it is not reproduced, copied, or disclosed to a third party, either wholly or in part, without the consent of Hellermann Tyton.

Drawn: RLV, 12/03/2015  
Approved: KAC, 12/03/2015

**HellermannTyton**  
North America  
Email: corp@htamericas.com  
Web: www.hellermann.tyton.com

Article/Type-No: WSMB5AHB  
Title: WIDE STRAP ADHESIVE MOUNT  
Drawing-No: 13-0220-004-CSU  
PRODUCTION : Phase

Scale: 3:2  
Project Number: PRP13-0220  
Format: B  
Sheet: 1/1