



Chipsmall Limited consists of a professional team with an average of over 10 year of expertise in the distribution of electronic components. Based in Hongkong, we have already established firm and mutual-benefit business relationships with customers from,Europe,America and south Asia,supplying obsolete and hard-to-find components to meet their specific needs.

With the principle of “Quality Parts,Customers Priority,Honest Operation,and Considerate Service”,our business mainly focus on the distribution of electronic components. Line cards we deal with include Microchip,ALPS,ROHM,Xilinx,Pulse,ON,Everlight and Freescale. Main products comprise IC,Modules,Potentiometer,IC Socket,Relay,Connector.Our parts cover such applications as commercial,industrial, and automotives areas.

We are looking forward to setting up business relationship with you and hope to provide you with the best service and solution. Let us make a better world for our industry!



Contact us

Tel: +86-755-8981 8866 Fax: +86-755-8427 6832

Email & Skype: info@chipsmall.com Web: www.chipsmall.com

Address: A1208, Overseas Decoration Building, #122 Zhenhua RD., Futian, Shenzhen, China



THIS DRAWING IS UNPUBLISHED. RELEASED FOR PUBLICATION 20
 © COPYRIGHT 20 BY TYCO ELECTRONICS CORPORATION. ALL RIGHTS RESERVED.

LOC	DIST	REVISIONS			
P	LTR	DESCRIPTION	DATE	DWN	APVD
	E	REV. NOTES, DIMS. AND LAYOUTS	17NOV2009	DW	GG
	F	REV PER ECO-09-027569	11DEC2009	DW	GG
	F1	REV PER ECO 12-016455	13SEP2012	DW	GG

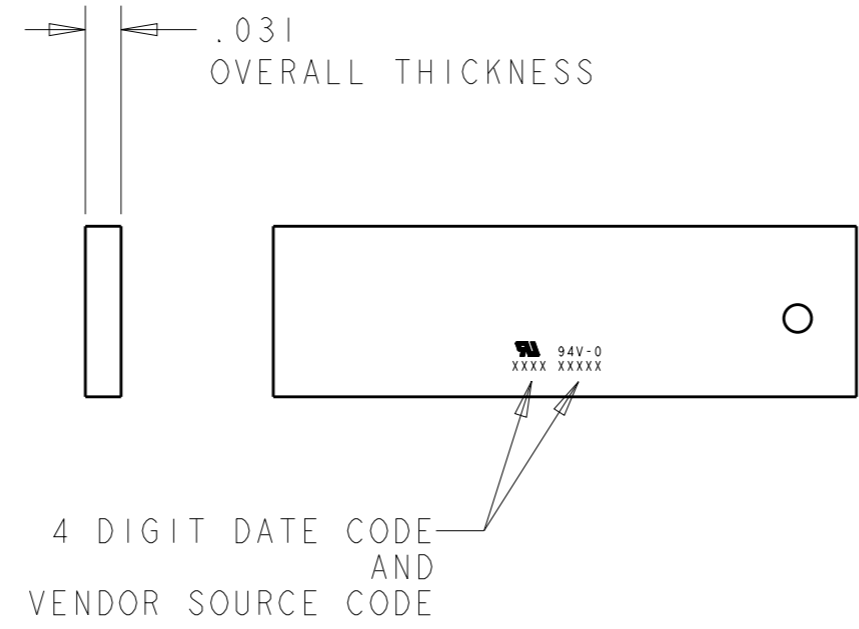
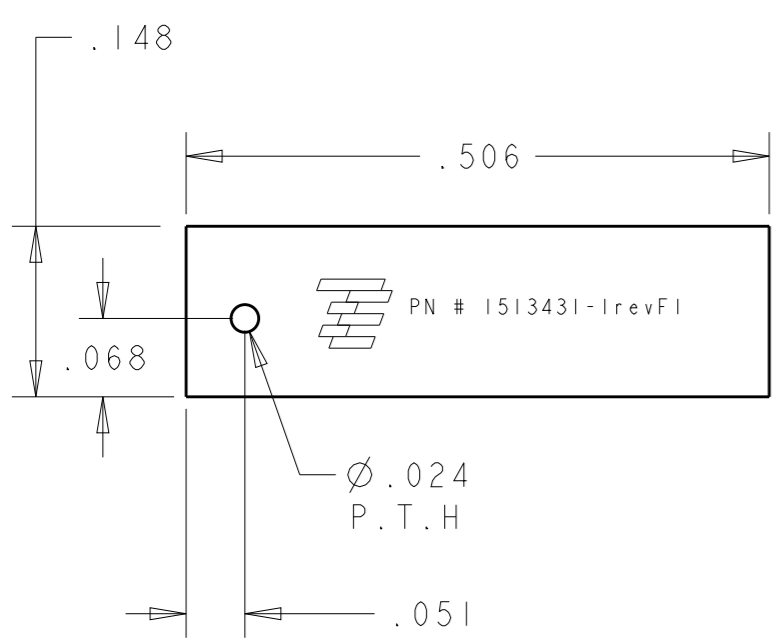

1513431-2 AS SHOWN

- NOTES: UNLESS OTHERWISE SPECIFIED.
- FABRICATE TO MEET IPC - 6012, CLASS 2. INSPECT TO MEET IPC - A - 600, CLASS 2.
 - PRIMARY AND SECONDARY SIDES SHOWN.
 - MATERIAL : GETEK 4 PLY (7628) .028 THK. P/N ML200D, 1/2 OZ. COPPER BOTH SIDES. DIELECTRIC CONSTANT @ 1MHZ 4.2 ± 0.1.
 - FINISH:
 A: 1/2 Oz COPPER PLATING.
 B: SOLDERMASK OVER BARE COPPER (SMOBC).
 C: MASK BOTH SIDES OF PCB WITH LPI SOLDERMASK. SOLDERMASK COLOR: NATURAL GREEN.
 D: IMMERSION TIN PLATING
 - THREE PLACE TOLERANCES: ±.009
 - PACKAGING: SINGULATED PARTS TO BE SECURELY SHRINK WRAPPED, BAGGED OR VACUUM PACKED IN BULK FOR TAPE AND REEL, SEE SHEET 2
 - PARTS ARE COMPLIANT TO ROHS STANDARDS PER TYCO ELECTRONICS STANDARD TEC-138-702.
 - CONSULT TYCO ELECTRONICS DATA SHEET DSI513431
 - CONTACT TYCO ELECTRONICS ENGINEERING PRIOR TO DESIGNING INTO AN APPLICATION

FOR TAPE AND REEL PACKAGING, ORDER P/N 1513431-1
 FOR BULK PACKAGING, ORDER P/N 1513431-2

THIS DRAWING IS A CONTROLLED DOCUMENT FOR TYCO ELECTRONICS CORPORATION. IT IS SUBJECT TO CHANGE AND THE CONTROLLING ENGINEERING ORGANIZATION SHOULD BE CONTACTED FOR THE LATEST REVISION.		DWN VG 19DEC2007	Tyco Electronics Rochester, New York 14623	
DIMENSIONS: INCHES		CHK -	NAME 802.11b Diversity Antenna Fabrication Drawing	
TOLERANCES UNLESS OTHERWISE SPECIFIED: 0 PLC ±- 1 PLC ±- 2 PLC ±- 3 PLC ±- 4 PLC ±- ANGLES ±-		APVD -	SIZE A3 CAGE CODE 00779 DRAWING NO 1513431 RESTRICTED TO -	
MATERIAL -		PRODUCT SPEC -	SCALE 1:1 SHEET 1 OF 2 REV F1	
FINISH -		APPLICATION SPEC -	CUSTOMER DRAWING	
		WEIGHT -		

THIS DRAWING IS UNPUBLISHED. RELEASED FOR PUBLICATION 20
 © COPYRIGHT 20 BY TYCO ELECTRONICS CORPORATION. ALL RIGHTS RESERVED.

LOC	DIST	REVISIONS					
		P	LTR	DESCRIPTION	DATE	DWN	APVD
HQ	00		-	SEE SHEET 1	-	-	-

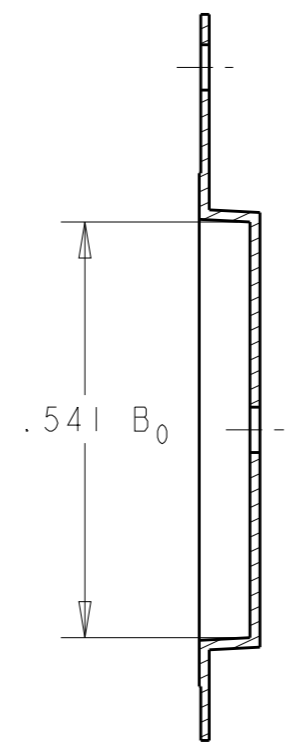
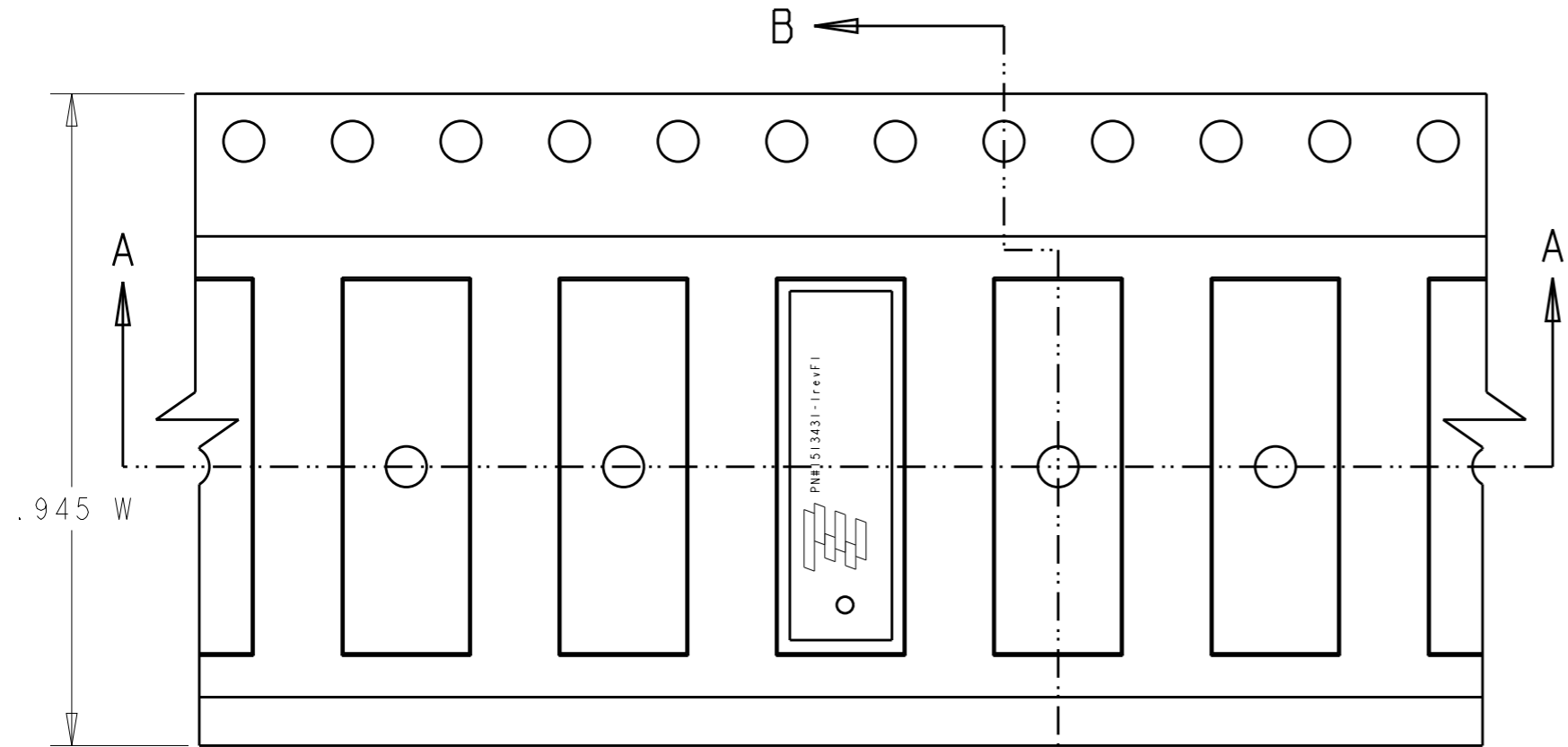

SECTION B-B

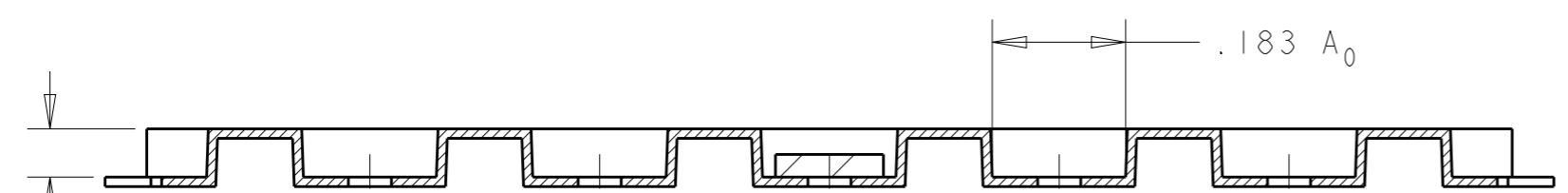

SECTION A-A

1513431-1 AS SHOWN

- NOTES: UNLESS OTHERWISE SPECIFIED.
- REFER TO TYCO ELECTRONICS DRAWING NO. C-1513126 FOR TAPE SPECIFIC DIMENSIONS
 - PARTS ARE COMPLIANT TO RoHS STANDARDS PER TYCO ELECTRONICS STANDARD TEC-138-702

THIS DRAWING IS A CONTROLLED DOCUMENT FOR TYCO ELECTRONICS CORPORATION. IT IS SUBJECT TO CHANGE AND THE CONTROLLING ENGINEERING ORGANIZATION SHOULD BE CONTACTED FOR THE LATEST REVISION.		DWN	19DEC2007		Tyco Electronics Rochester, New York 14623			
DIMENSIONS: INCHES		CHK	-					
		APVD	-		NAME 802.11b Diversity Antenna Fabrication Drawing			
TOLERANCES UNLESS OTHERWISE SPECIFIED: 0 PLC ±. 1 PLC ±. 2 PLC ±. 3 PLC ±. 4 PLC ±. ANGLES ±.		PRODUCT SPEC	-					
MATERIAL	-	APPLICATION SPEC	-		SIZE	CAGE CODE	DRAWING NO	RESTRICTED TO
FINISH	-	WEIGHT	-		A3	00779	C-1513431	-
CUSTOMER DRAWING					SCALE	SHEET 2 OF 2		REV F1