



Chipsmall Limited consists of a professional team with an average of over 10 year of expertise in the distribution of electronic components. Based in Hongkong, we have already established firm and mutual-benefit business relationships with customers from,Europe,America and south Asia,supplying obsolete and hard-to-find components to meet their specific needs.

With the principle of "Quality Parts,Customers Priority,Honest Operation,and Considerate Service",our business mainly focus on the distribution of electronic components. Line cards we deal with include Microchip,ALPS,ROHM,Xilinx,Pulse,ON,Everlight and Freescale. Main products comprise IC,Modules,Potentiometer,IC Socket,Relay,Connector.Our parts cover such applications as commercial,industrial, and automotives areas.

We are looking forward to setting up business relationship with you and hope to provide you with the best service and solution. Let us make a better world for our industry!



Contact us

Tel: +86-755-8981 8866 Fax: +86-755-8427 6832

Email & Skype: info@chipsmall.com Web: www.chipsmall.com

Address: A1208, Overseas Decoration Building, #122 Zhenhua RD., Futian, Shenzhen, China



Liquid to Air Heat Exchanger System



WATER COOLED HEAT EXCHANGER UNITS FOR MEDICAL AND INDUSTRIAL SYSTEMS

The WL2000 is a re-circulating liquid to air heat exchanger that offers dependable, compact performance by removing large amounts of heat from a liquid circuit. The coolant is re-circulated using a high pressure pump to assure maximum flow rate. Heat from coolant is absorbed by a radiant heat exchanger and dissipated into the ambient environment using brand name fan. Manual adjustments can be made to control flow switch. Customized features are available, however, MOQ applies.

FEATURES

- Compact design
- Reliable operation
- Adjustable flow switch
- Bypass valve protection

APPLICATIONS

- Medical imaging systems
- Photonics laser systems
- X-Ray scanning systems
- Semiconductor fabrication

Americas: +1.919.597.7300
Europe: +46.31.420530
Asia: +86.755.2714.1166
ets.sales@lairdtech.com
www.lairdtech.com

SPECIFICATIONS

Performance	
Cooling capacity ¹	2,000 Watts
Flow Rate	> 4.4 lpm @ 4 bar
Operation	
Coolant	Water or Water/Glycol
Operational temperature range ²	10°C to 40°
Storage temperature range (w/o coolant)	-25°C to 70°C
Humidity range	20% to 80%
Input Voltage	230 VAC
Frequency	50 Hz
Current Draw	2.1 Amps
Noise	< 70 dB(A)
Flow switch open	4.0 lpm
Maximum forward pressure	6.7 bar
Physical	
Dimensions (H x W x D)	50.5 x 30.5 x 30.0 cm
Weight (w/o coolant)	26.5 kg
Coolant Capacity	2.5 L
Couplings	Walther Type MD 006

1. Capacity rating is given at a temperature of 25°C (77°F) for the ambient air and water outlet temperature of 11°C.

2. For ambient conditions outside this range, please contact Laird Technologies

Performance Curves

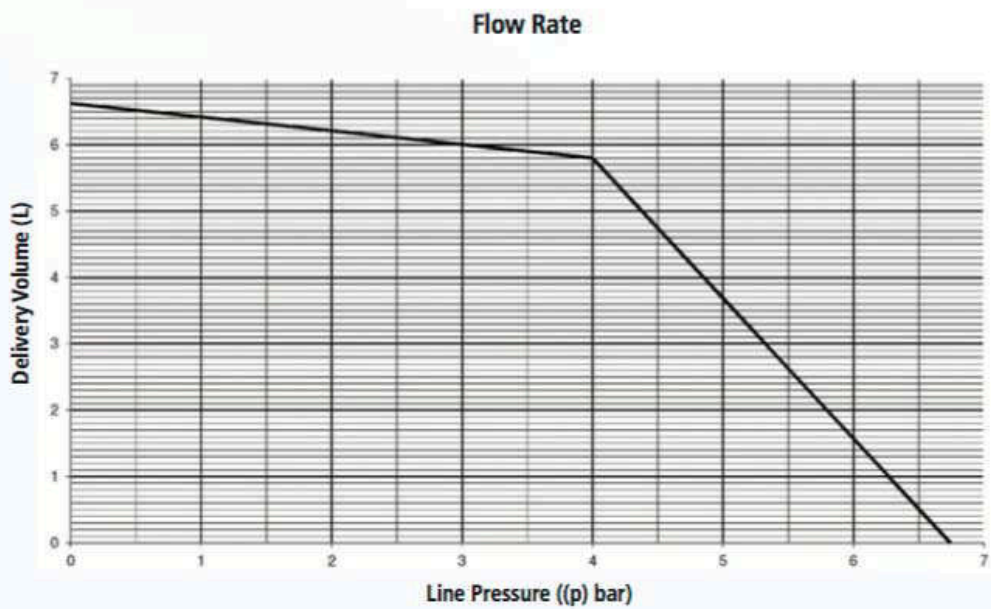
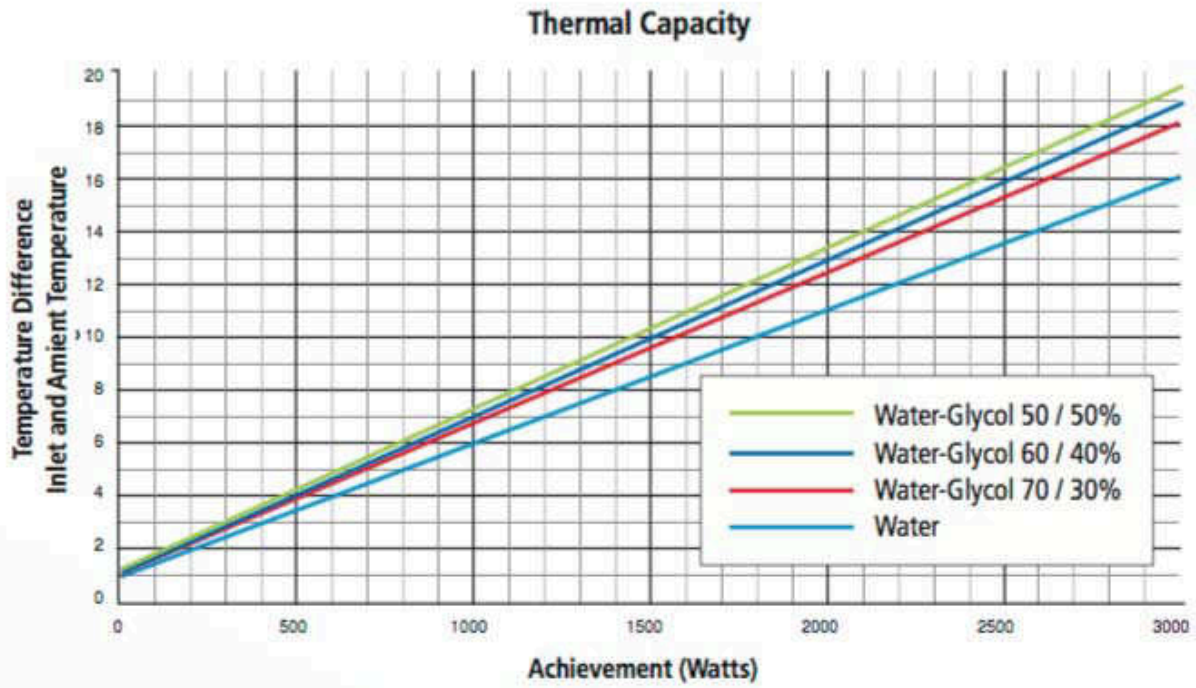

ISOMETRIC DRAWINGS

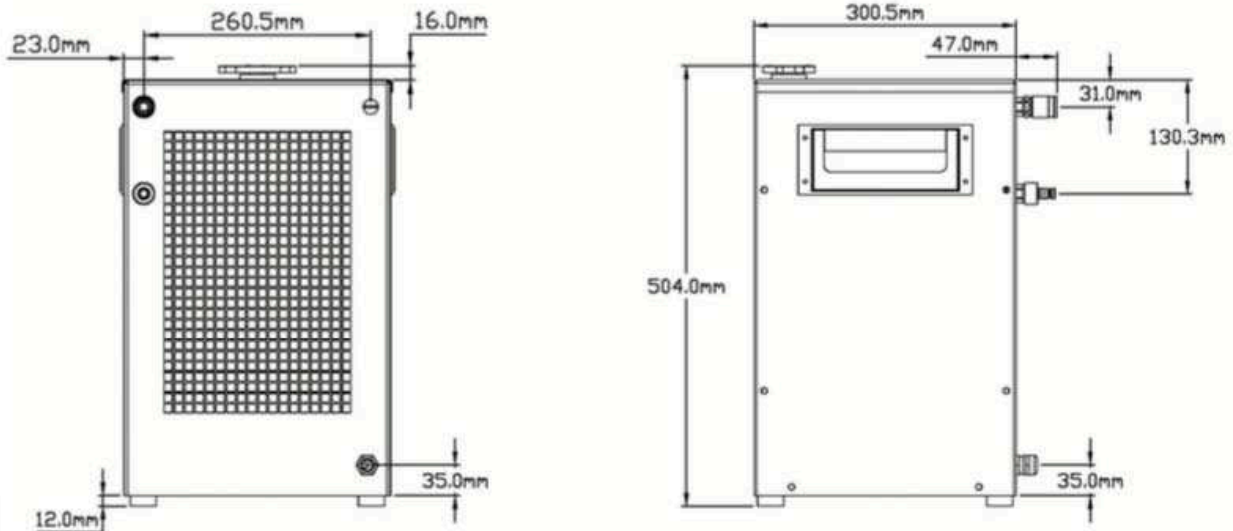

NOTES

1. Check coolant level regularly. For optimal cooling performance, coolant level should always be above radiator fins.
2. Hose selection should be of material and thickness to support pressure resistance and coolant type.
3. Manual adjustments can be made to control pressure and flow rate.
4. Check pump filter and dust on heat exchanger periodically for cleaning.

ORDERING INFORMATION

PART NUMBER EXAMPLE

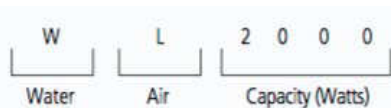

LAIRD-ETS-WL-2000-DATA-SHEET-101416

Any information furnished by Laird Technologies, Inc. and its agents is believed to be accurate and reliable. All specifications are subject to change without notice. Responsibility for the use and application of Laird Technologies materials rests with the end user. Laird Technologies makes no warranties as to the fitness, merchantability, suitability or non-infringement of any Laird Technologies materials or products for any specific or general uses. Laird Technologies shall not be liable for incidental or consequential damages of any kind. All Laird Technologies products are sold pursuant to the Laird Technologies' Terms and Conditions of sale in effect from time to time, a copy of which will be furnished upon request. © Copyright 2016 Laird Technologies, Inc. All Rights Reserved. Laird, Laird Technologies, the Laird Technologies Logo, and other marks are trademarks or registered trademarks of Laird Technologies, Inc. or an affiliate company thereof. Other product or service names may be the property of third parties. Nothing herein provides a license under any Laird Technologies or any third party intellectual property rights.