



Chipsmall Limited consists of a professional team with an average of over 10 year of expertise in the distribution of electronic components. Based in Hongkong, we have already established firm and mutual-benefit business relationships with customers from,Europe,America and south Asia,supplying obsolete and hard-to-find components to meet their specific needs.

With the principle of “Quality Parts,Customers Priority,Honest Operation,and Considerate Service”,our business mainly focus on the distribution of electronic components. Line cards we deal with include Microchip,ALPS,ROHM,Xilinx,Pulse,ON,Everlight and Freescale. Main products comprise IC,Modules,Potentiometer,IC Socket,Relay,Connector.Our parts cover such applications as commercial,industrial, and automotives areas.

We are looking forward to setting up business relationship with you and hope to provide you with the best service and solution. Let us make a better world for our industry!



Contact us

Tel: +86-755-8981 8866 Fax: +86-755-8427 6832

Email & Skype: info@chipsmall.com Web: www.chipsmall.com

Address: A1208, Overseas Decoration Building, #122 Zhenhua RD., Futian, Shenzhen, China



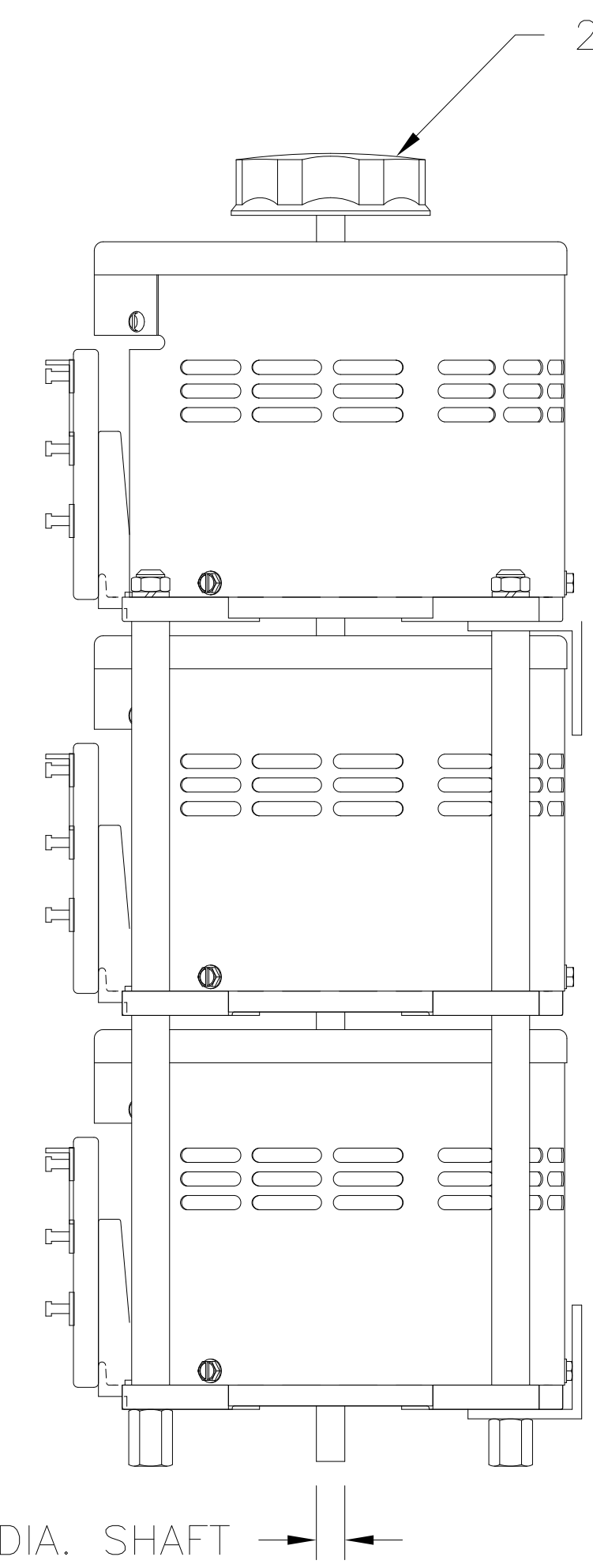
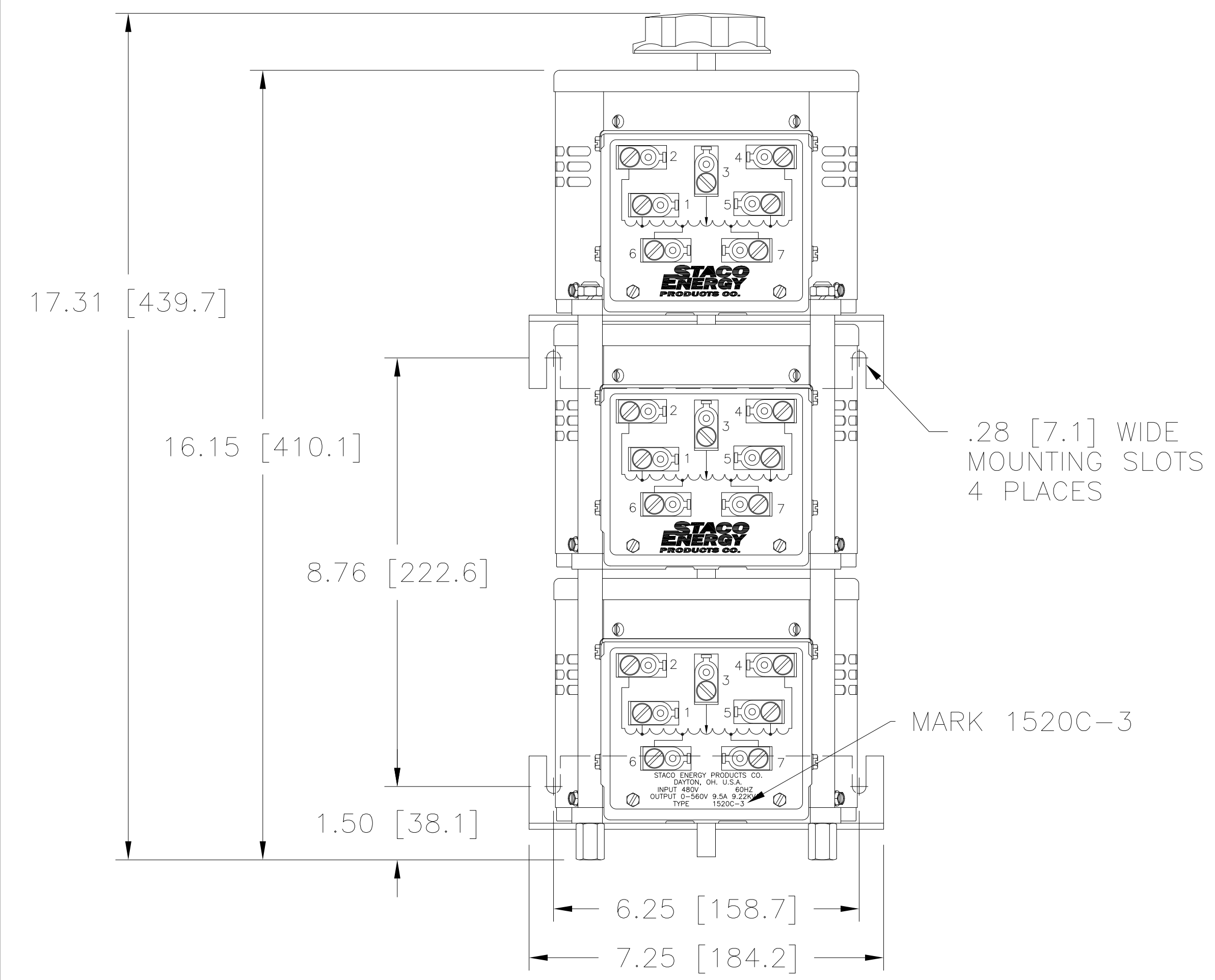

NOTE:
UNIT IS SUPPLIED WITH A 3.75 [95.2] DIA.
0-100 GRADUATED DIAL PLATE FOR PANEL MOUNTING.

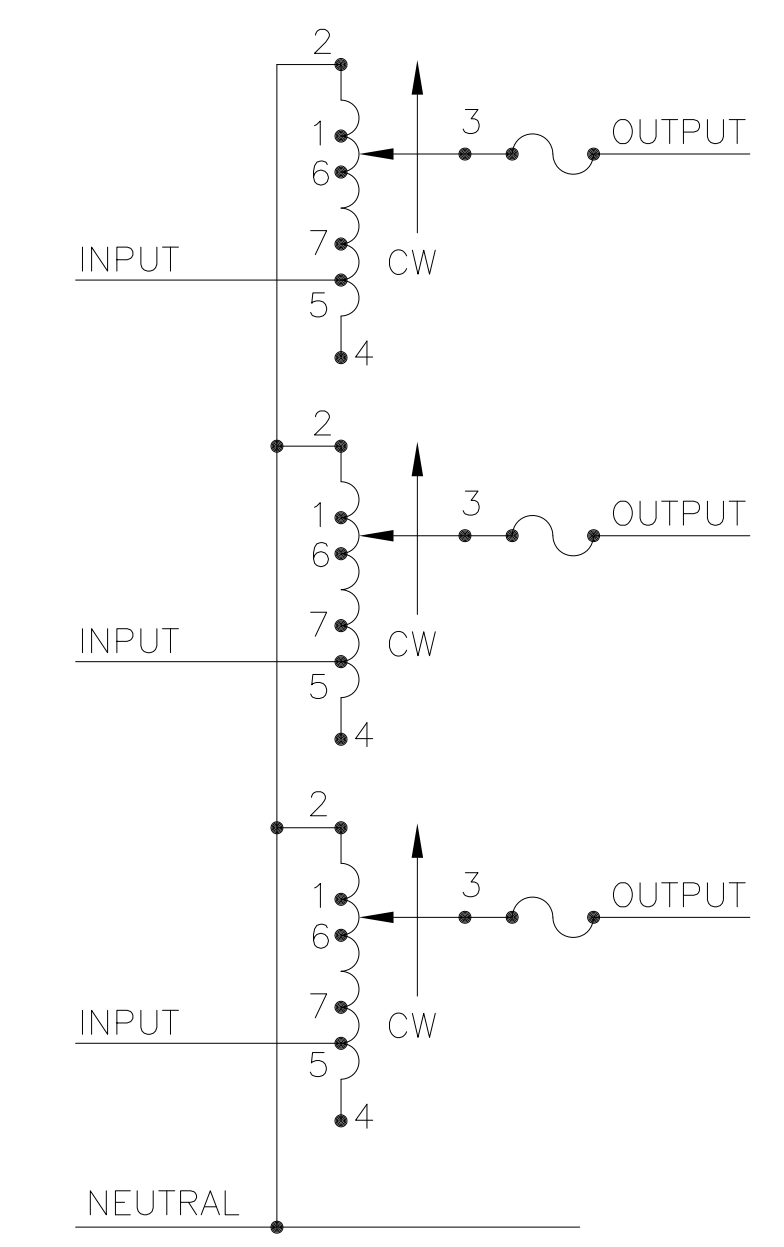

SCHEMATIC
THREE PHASE WYE
FUSES RECOMMENDED BUT NOT SUPPLIED

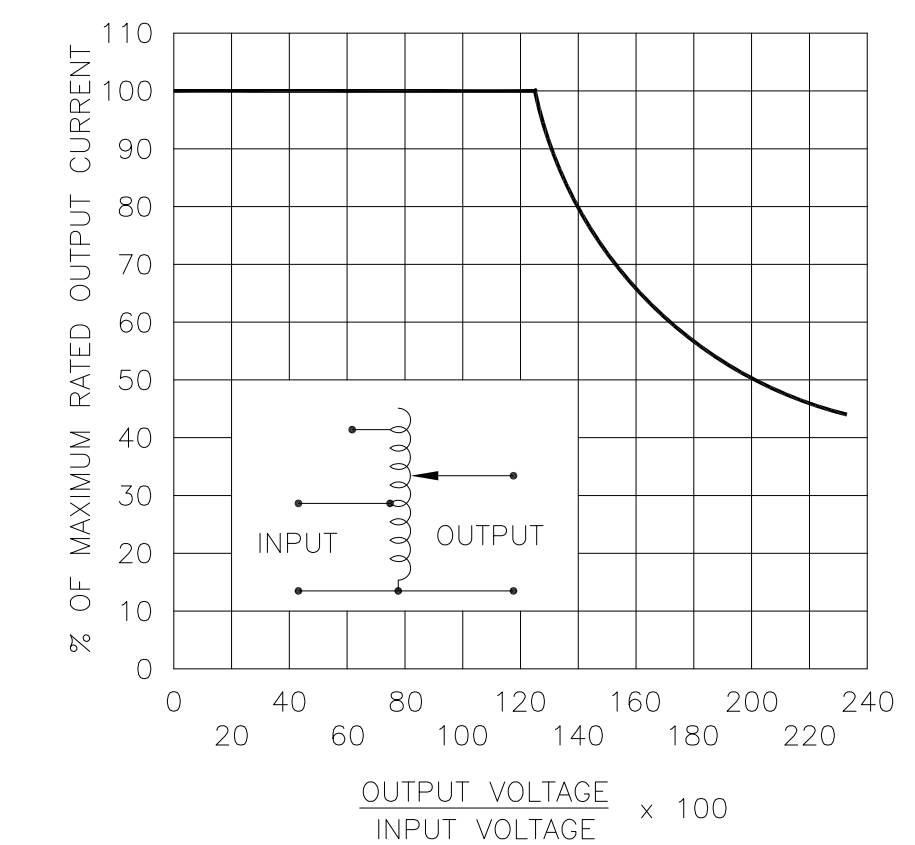
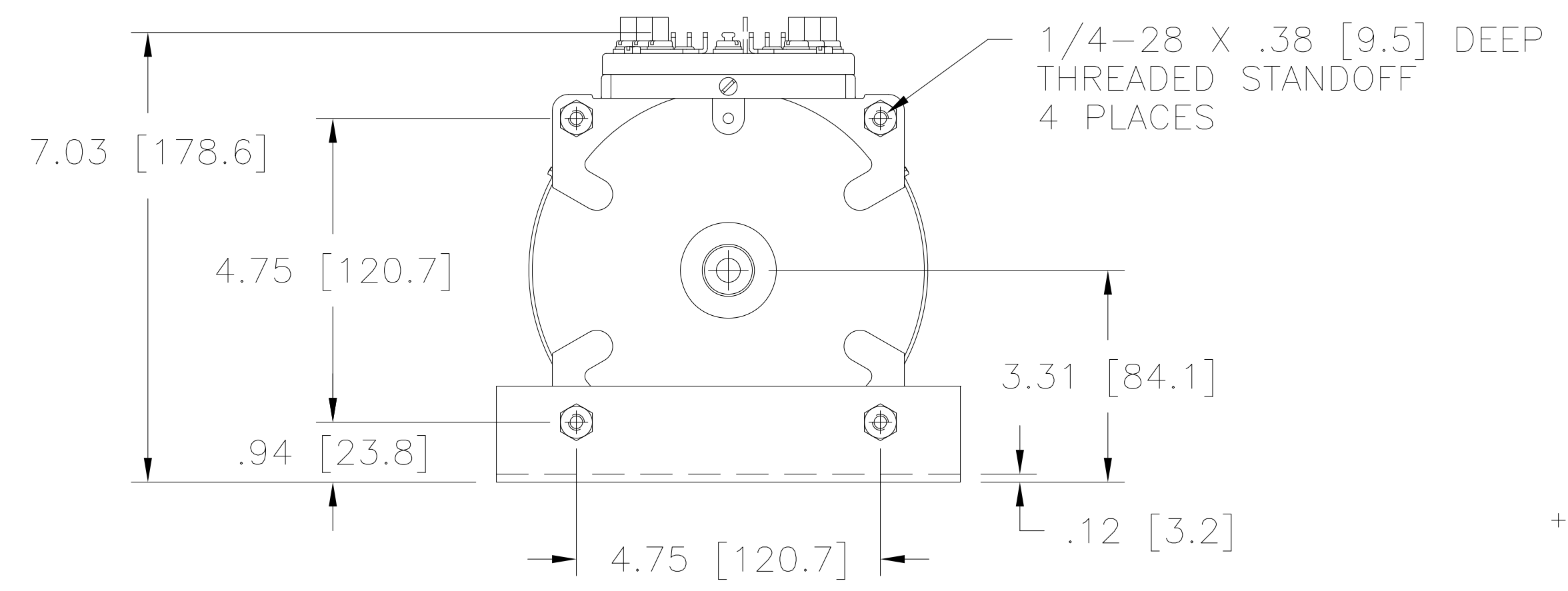

FIGURE A
MAXIMUM OUTPUT CURRENT OF ANY
DUAL INPUT VOLTAGE OR VOLTAGE DOUBLER
UNIT OPERATED AT LOWER INPUT VOLTAGE.

MAXIMUM OUTPUT CURRENT IN OUTPUT VOLTAGE RANGE FROM 0 TO 25% ABOVE LINE VOLTAGE. AT HIGHER OUTPUT VOLTAGES, THE OUTPUT CURRENT MUST BE REDUCED ACCORDING TO THE DERATING CURVE FIGURE A.

§ MAXIMUM KVA AT MAXIMUM OUTPUT VOLTAGE AND CORRESPONDING DERATED OUTPUT CURRENT. MAXIMUM KVA FOR LOWER VOLTAGES MAY BE CALCULATED FROM DERATING CURVE FIGURE A.

++ LINE TO LINE VOLTAGE.

π IF GANGED UNITS ARE USED IN A SYSTEM THAT ORDINARILY HAS A COMMON NEUTRAL OR GROUND BETWEEN SOURCE AND LOAD, THE NEUTRAL OR GROUND MUST BE CONNECTED TO THE COMMON TERMINALS OF THE VARIABLE TRANSFORMER ASSEMBLY. IF THE SYSTEM HAS NO NEUTRAL, THE LOAD MUST BE BALANCED OR THE TRANSFORMER WILL BE DAMAGED.

■ JUMPER PROVIDED IN STANDARD COMMON POSITION AND SHOULD BE MOVED OR REMOVED AS REQUIRED.

SPECIFICATIONS													
WIRING	INPUT		OUTPUT				SHAFT ROTATION TO INCREASE VOLTAGE	TERMINAL CONNECTIONS					
	VOLTS	HERTZ	VOLTS	CONSTANT CURRENT LOAD MAX. AMPS	CONSTANT IMPEDANCE LOAD MAX. KVA	MAX. AMPS		MAX. KVA	FOR INCREASING VOLTAGE AS VIEWED FROM BASE END ■				
THREE PHASE WYE π	480	50/60	0-480	9.5	7.90	12	10	CW	2-2-2	4-4-4	3-3-3		
		60	0-560	9.5	9.21	—	—	CCW	4-4-4	2-2-2	3-3-3		
	++	60	0-560	9.5	9.21	—	—	CW	1-1-1	4-4-4	3-3-3		
			0-560	9.5#	3.96§	—	—	CCW	5-5-5	2-2-2	3-3-3		
		++	240	60	0-560	9.5#	3.96§	—	—	CW	7-7-7	4-4-4	3-3-3
			++	++	++	++	++	++	++	CCW	6-6-6	2-2-2	3-3-3

UNLESS OTHERWISE SPECIFIED, TOLERANCE IS ±	DECIMALS	HOLE	ANGLES	DRAFT	UNITS	TITLE:
.XX	.005	.06	1°	1-1/2°	IN (mm)	SPEC. CONTROL DRAWING
.XXX	.005	.005	1°	1-1/2°	IN (mm)	VARIABLE TRANSFORMER
MATERIAL:						MODEL: 1520C-3
ALL DIMENSIONS APPLY AFTER PLATING.						
The information and design disclosed herein was originated by and is the property of STACO ENERGY PRODUCTS CO., which reserves all patent, proprietary, design, manufacturing, reproduction, use and sale rights thereto, and to any article disclosed therein except to the extent rights are expressly granted to others. The foregoing does not apply to vendor proprietary parts.						
DRAWN BY	DATE	FIRST USED ON	DO NOT SCALE DWG.	DWG. NO.		
T.SNAY	3/21/14	1520C-3		031-3974		
CHECKER	DATE	WEIGHT APPROX.	CAGE CODE	D		
		66 LBS	83008			
ENGINEER	DATE	SCALE	SHEET			
		.50=1	1 OF 1			



A Components Corporation of America Company
304 Gessie Boulevard Dayton, Ohio 45403 USA