



Chipsmall Limited consists of a professional team with an average of over 10 year of expertise in the distribution of electronic components. Based in Hongkong, we have already established firm and mutual-benefit business relationships with customers from,Europe,America and south Asia,supplying obsolete and hard-to-find components to meet their specific needs.

With the principle of “Quality Parts,Customers Priority,Honest Operation,and Considerate Service”,our business mainly focus on the distribution of electronic components. Line cards we deal with include Microchip,ALPS,ROHM,Xilinx,Pulse,ON,Everlight and Freescale. Main products comprise IC,Modules,Potentiometer,IC Socket,Relay,Connector.Our parts cover such applications as commercial,industrial, and automotives areas.

We are looking forward to setting up business relationship with you and hope to provide you with the best service and solution. Let us make a better world for our industry!



Contact us

Tel: +86-755-8981 8866 Fax: +86-755-8427 6832

Email & Skype: info@chipsmall.com Web: www.chipsmall.com

Address: A1208, Overseas Decoration Building, #122 Zhenhua RD., Futian, Shenzhen, China



THIS DRAWING IS UNPUBLISHED. RELEASED FOR PUBLICATION
 © COPYRIGHT BY TYCO ELECTRONICS CORPORATION. ALL RIGHTS RESERVED.

LOC	DIST	REVISIONS			
P	LTR	DESCRIPTION	DATE	DWN	APVD
G	14	G	REV PER ECR 09-025674	30NOV09	JR TM

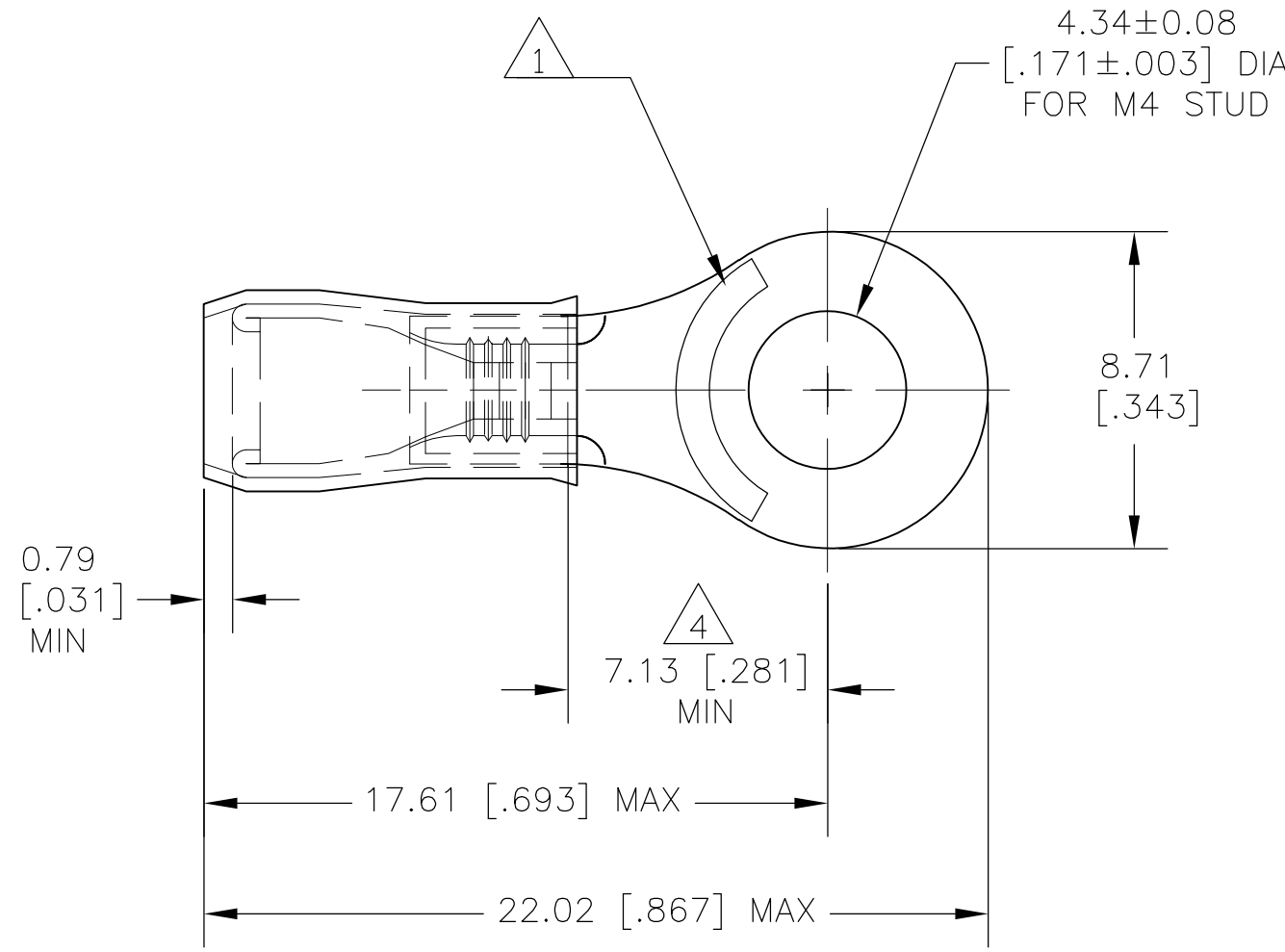

- 1 STAMP AMP 14-12, LOCATION AS SHOWN.
- 2 WIRE INSULATION DIA RANGE IS 2.0-3.2 [.080-.125] DIA.
- 3 TONGUE MATERIAL THK IS 0.75 ± 0.05 [.0295 ± 0.002]
- 4 DIMENSION APPLIES FROM CENTER OF STUD HOLE TO EDGE OF WIRE BARREL.
- 5 MATERIAL: BODY - COPPER PER ASTM B-152 SLEEVE - NYLON, COLOR WHITE
- 6 FINISH: BODY - TIN PLATE PER ASTM B-545
- 7 MAX RECOMMENDED OPERATING TEMP 105°C
- 8 VOLTAGE RATING: 300 V MAX
- 9 WIRE CROSS SECTIONAL AREA RANGE: 1.65-3.45mm² [3,260-6,800] CMA

AMP
WIRE RANGE

14-12 AWG
SOLID OR STRANDED

500	LOOSE PIECE	152873
QTY	PACKAGING TYPE	PART NO

THIS DRAWING IS A CONTROLLED DOCUMENT.		DWN jr_ruth 23AUG07	Tyco Electronics Corporation Harrisburg, PA 17105-3608	
DIMENSIONS: MM [INCHES]		CHK T MICHELUTTI 23AUG07		
TOLERANCES UNLESS OTHERWISE SPECIFIED:		APVD T MICHELUTTI 23AUG07	NAME RING TONGUE, PIDG, WIRE SIZE: 14-12 AWG	
0 PLC ± - 1 PLC ± - 2 PLC ± 0.20 [.008] 3 PLC ± - 4 PLC ± - ANGLES ± 5°		PRODUCT SPEC -	SIZE A3	
MATERIAL - 5		APPLICATION SPEC -	CAGE CODE 00779	DRAWING NO G-152873
FINISH - 6		WEIGHT -	RESTRICTED TO -	
CUSTOMER DRAWING			SCALE 5:1	SHEET 1 OF 1
			REV G	