



Chipsmall Limited consists of a professional team with an average of over 10 year of expertise in the distribution of electronic components. Based in Hongkong, we have already established firm and mutual-benefit business relationships with customers from,Europe,America and south Asia,supplying obsolete and hard-to-find components to meet their specific needs.

With the principle of “Quality Parts,Customers Priority,Honest Operation,and Considerate Service”,our business mainly focus on the distribution of electronic components. Line cards we deal with include Microchip,ALPS,ROHM,Xilinx,Pulse,ON,Everlight and Freescale. Main products comprise IC,Modules,Potentiometer,IC Socket,Relay,Connector.Our parts cover such applications as commercial,industrial, and automotives areas.

We are looking forward to setting up business relationship with you and hope to provide you with the best service and solution. Let us make a better world for our industry!



## Contact us

Tel: +86-755-8981 8866 Fax: +86-755-8427 6832

Email & Skype: info@chipsmall.com Web: www.chipsmall.com

Address: A1208, Overseas Decoration Building, #122 Zhenhua RD., Futian, Shenzhen, China



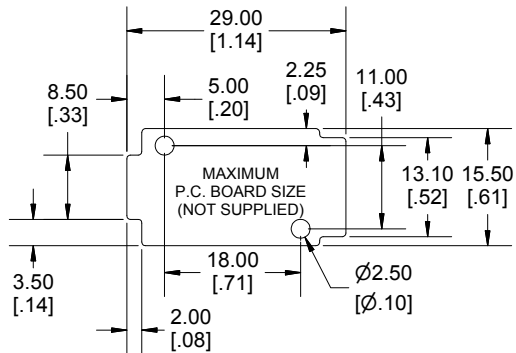
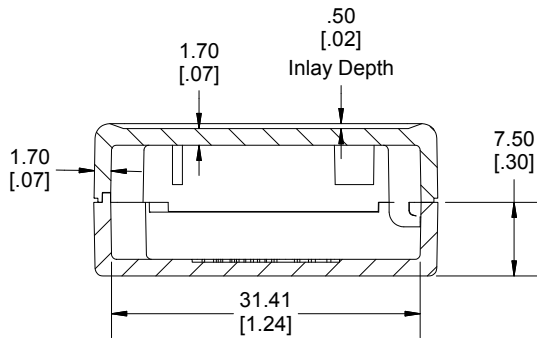
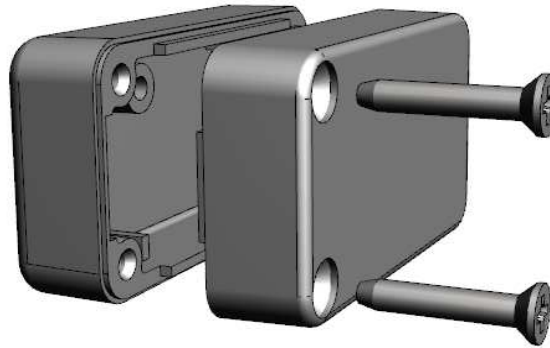
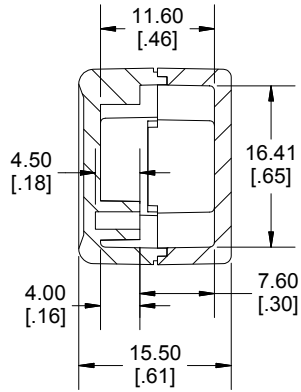
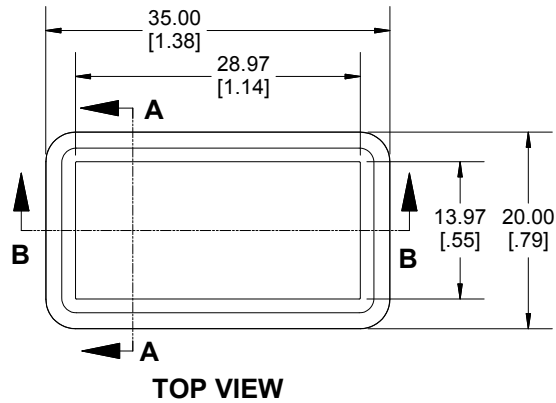

Enclosures can be Factory Modified ( Milling, Drilling, Printing etc.)  
 Contact Factory [mjm@hammondmfg.com](mailto:mjm@hammondmfg.com) for quotes  
 Solid models of this enclosure available in STEP or IGES.  
 (Part number and text placement/orientation on our products are subject to change,  
 we do not recommend using them as a locating reference for modification purposes)

**NOTE**

Purchased assembly includes box, lid, 2 cover screws.  
 Enclosure molded from general purpose ABS Plastic.  
 Other materials / colours available consult factory.

**Recommended Torque : (35-43) Ozf.in / (25-30) cN.m**

**PART NUMBERS**

1551A Enclosure	
Black Enclosure - Ral 9011 - UL94 - HB	1551ABK
Gray Enclosure - RAL 7035 - UL94 - HB	1551AGY
Translucent Blue - UL94 - HB	1551ATBU
Translucent Clear - UL94 - HB	1551ACL
Translucent Smoke - UL94 - HB	1551ATSK
Translucent Red - UL94 - HB	1551ATRD

**ACCESSORIES**

P.C. Board Plastite Self Tapping Screw [#2 x 3/16" self-tapping (4.8mm)]	1553WTS100 (Pkg 100)
Plated Cover Screws #2 X 1/2" Self-tapping	1551USB50 (Pkg 50)
Black Cover Screws #2 X 1/2" Self-tapping	1551USB50BK (Pkg 50)

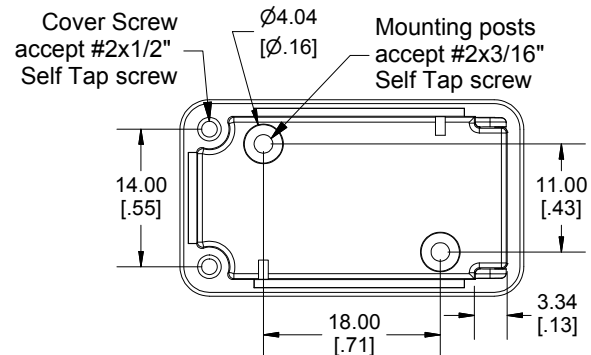
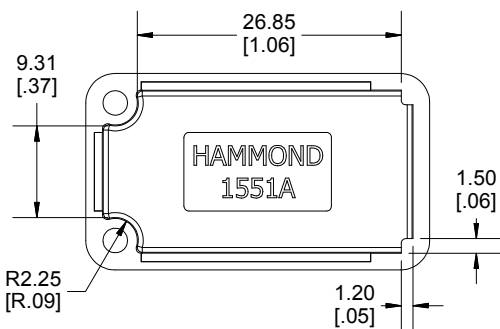

Dimensions:  
 mm  
 [inches]

